

Tensione nominale entrata Nominal input voltage	Vac	220÷240
Tensione in uscita Nominal Output Voltage	Vac	220÷240
Frequenza Frequency	Hz	50/60
Max carico resistivo Max resistive load	W	500
Max carico induttivo Max inductive load	VA	200
Max carico LED Max load LED	W	100
Temperatura ambiente Ta° Ambient Temperature Ta°	°C	-20...40
Protezione termica Thermal protection		NO
Protezione sovraccarico Overload protection		NO
Protezione sovratensioni Overcurrents protection		NO
Protezione corto circuito Short circuit protection		NO
Tecnologia Technology		Relè Relay
Angolo di rilevamento Detection Angle	360°	ambito visivo ellittico elliptical visual field
Ampiezza di rilevamento Detection Width	Ø	10m
Altezza di montaggio Assembly height	m	2÷5
Altezza minima Minimum Height	m	1,7
Sensibilità Sensibility	Lux	10÷2000
Ritardo allo spegnimento Timing switch of delay		10"÷7'
Sezioni cavi Cables section	mm <sup>2</sup>	2,5
Assorbimento a riposo Stand-by	W	<0,5

Angolo di rilevamento  
Detection angle

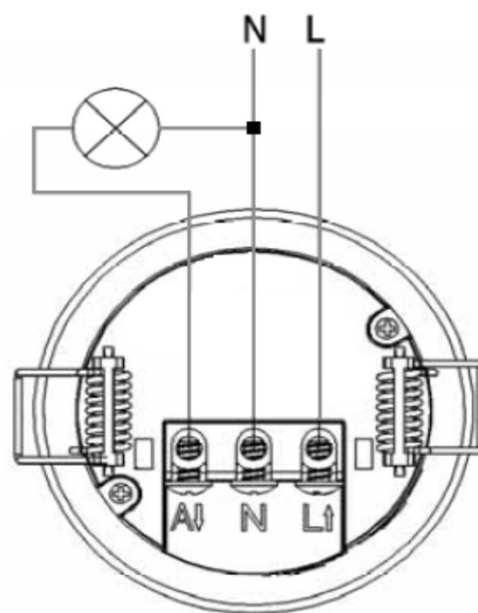
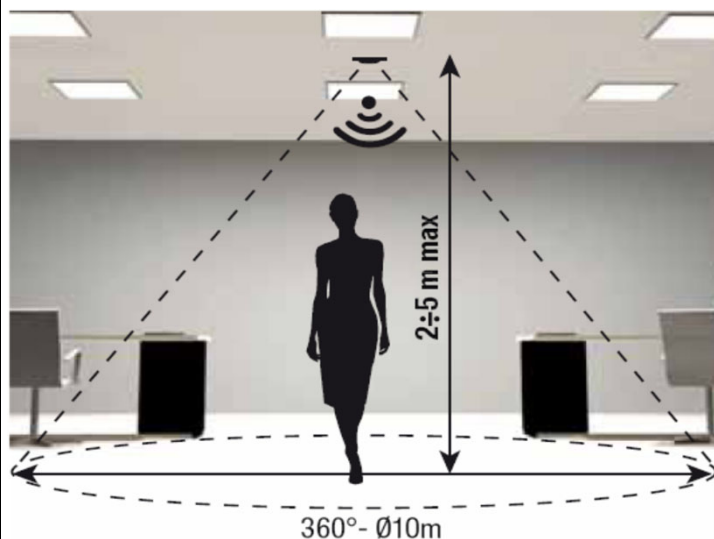

RELCO group persegue una politica di continua ricerca e sviluppo, quindi si riserva di variare in qualsiasi momento e senza preavviso le caratteristiche dei prodotti.

RELCO group pursues a policy of continuous research and development and reserves the right to change at any time and without prior notice, the characteristics of the products.