

LED AGP ATEX 2-22



Riflettore da incasso particolarmente adatto per magazzini, garage, stazioni di servizio e luoghi con atmosfera potenzialmente esplosiva. Completo di alimentatore elettronico.

Installazione: ad incasso su superfici in cartongesso

Corpo e telaio: in alluminio pressofuso

PG: pressacavo in metallo M16 (cavo Ø 4÷8mm²)

Ottica: diffusore realizzata in PMMA resistente ai raggi UV

Sorgente: LED PHILIPS lumileds

Mantenimento del flusso luminoso minimo al 90% - 100.000h (L90B10) per il 90% dei LED

Driver: incorporato

Fattore di potenza ≥ 0,95.

Recessed reflector particularly suitable for warehouses, garages, service stations and places in general with potentially explosive atmosphere. Complete with electronic ballast.

Installation: recessed on plasterboard surfaces

Body and frame: die cast aluminum

PG: M16 metal cable gland (cable 4÷8mm²)

Optic: wide made of UV-resistant PMMA

Light source: LED PHILIPS lumileds

Maintenance of minimum luminous flux to 90% - 100.000h (L90B10) for 90% of LED.

Driver: certified.

Power factor ≥ 0,95.

Use: the light fitting is suitable for the environment with a danger of explosion of gas, dust and combustible fumes. The light fittings meet the requirements of Government Decree 116/2016 Coll. and European Community Directive N°. 2014/34/EU.

Floodlight

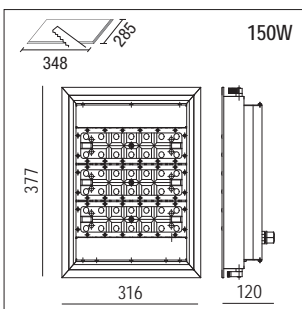
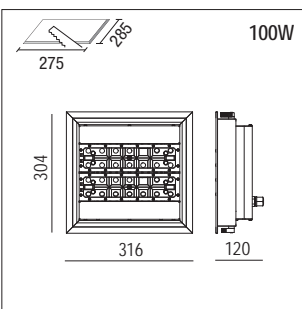

	100-240 Vac	110-240 Vac On demand	50/60 Hz

colour	W	Led SMD	angle	K	nominal lm tc = 25°C	lm output	lm/W	pcs	Kg	CELL
	100	N° 128 led 3030 2D	110°	5000	18.000	15.000	150	1	9,70	334096.100ATX
	150	N° 192 led 3030 2D	110°	5000	27.000	25.000	150	1	9,70	334096.150ATX

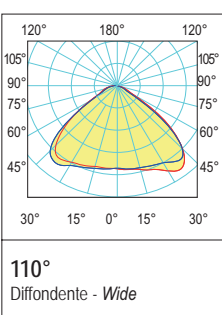

Protezione contro le atmosfere esplosive <i>Protection against explosive atmospheres</i>	II M2 G Ex deia IIC T4
Zona pericolosa ammessa <i>Hazardous area allowed</i>	Zona 2 - Zone 2 Zona 22 - Zone 22
Normative di riferimento <i>Standard references</i>	EN 60079-0:2012/A11:2013 EN 60079-10-1:2015 EN 60079-10-2:2015, EN 60079-7:2015 EN 60079-11:2012, EN 60079-1:2014 EN60079-31:2014

Dettagli - Details



Utilizzare il connettore impermeabile M16 per evitare danni all'alimentazione.
Use M16 waterproof connector, avoid hard power damage.



Il supporto per telaio innovativo non solo rende l'installazione più semplice, ma anche più solida.
The exquisite and innovated frame holder not only makes the installation more simple but also firmer.



Utilizzare un connettore impermeabile per il cablaggio interno, sicuro e veloce.
Use waterproof connector for internal wiring, safe, convenient & fast.



Connettore a innesto rapido innovativo, pulito ed efficiente.
Innovative pluggable connector, clean & efficient.



Di rapida installazione.
Convenient & fast installation.



Materiale non soggetto a problemi di corrosione.
With a non-corrosive material, not only exquisite appearance, but also no corrosion concerns.