

LED Compact

MADE IN
ITALY





LED Compact

Potenza*:	24W	Power*:	24W
Alimentazione:	220-240V~, 110V~ a richiesta.	Current:	220-240V~, 110V~ on request.
Funzionamento:	SA (Sempre accesa) - SE (Solo Emergenza)	Functioning:	M (Maintained) - N/M (Non-Maintained)
Conforme alle norme:	EN60598-1; EN60598-2-2; EN60598-2-22; EN62471; EN62031; EN61347-1; EN61347-2-7; EN1838; UNI11222	According to standard:	EN60598-1; EN60598-2-2; EN60598-2-22; EN62471; EN62031; EN61347-1; EN61347-2-7; EN1838; UNI11222
Grado di protezione:	IP42	IP Degree:	IP42
Inibizione:	vedi tabella	Inibition:	See table
Autonomia:	1h, 3h	Autonomy:	1h, 3h
Temperatura ambiente:	-20°C ÷ +50°C.	Operating ambient temperature:	-20°C ÷ +50°C.
Installazioni:	incasso controsoffitto.	Installation:	recessed false ceiling.
Alimentatore:	driver elettronico a corrente costante con batteria inclusa.	Driver:	Electronic constant current driver included battery.
Corpo:	Alluminio bianco RAL 9003, orientabile.	Body:	White Aluminum RAL 9003, orientable.
Sorgente:	Modulo LED 4000k a richiesta 3000K o 6000K	Light source:	LED module 4000K on demand 3000K or 6000K
Ottica:	Diffondente	Optic:	Narrow
Schermo:	Polycarbonato opale	Shield:	Opal polycarbonate

* Potenza indicativa per il confronto con tubo fluorescente (a parità di lumen prodotti).

* Power indicative by comparison with fluorescent tube (at the same produced lumen)

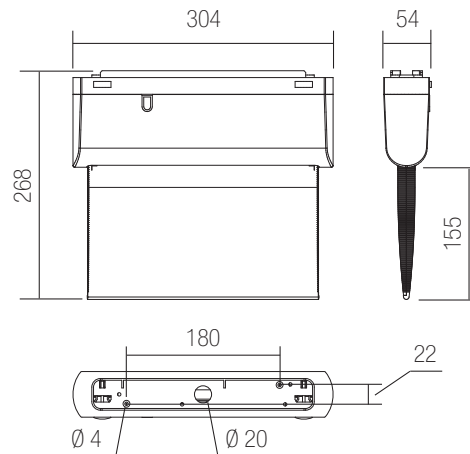

Accessori non inclusi - Not included accessoires

da ordinare separatamente - to be ordered separately

Codice/Code	Descrizione/Description	Pag.
8450P	1 Kit staffa parallela parete - Parallel wall bracket	18
8450T	2 Kit staffa perpendicolare parete - Perpendicular wall bracket	18
8450S	3 Kit per sospensione - Suspension kit	18
-	Kit per binario trifase (a richiesta) - three-pase track kit (on request)	-
8450C	4 Kit per controsoffitto con indicatore LED autodiagnosi - False ceiling kit with LED indicator autotest	18
R00325	5 Comando centralizzato per l'inibizione dell'emergenza - Controller Rest-mode.	19

Accessori inclusi - Included accessoires

Descrizione/Description

5 segnali di sicurezza (adesivi) - 5 safety signs (adhesives).

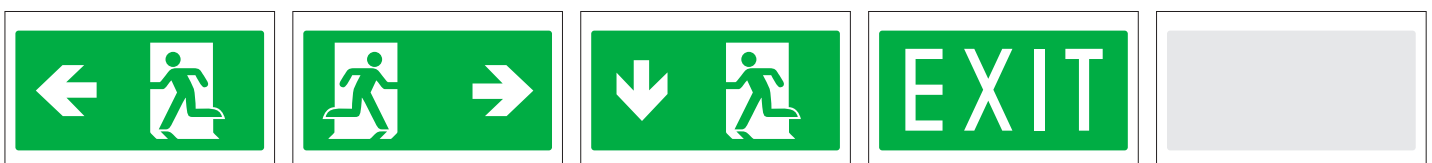

Installazione a soffitto (staffa inclusa)
Ceiling mounting (with included bracket)



Installazione a parete con staffa parallela
Wall mounting with parallel bracket



Installazione a bandiera 90° con staffa.
90° flag installation with bracket



Lampada per binario trifase (a richiesta)
Three-phase emergency lamp (on request)



Installazione a sospensione
Suspension installation



Installazione ad incasso con cornice
Recessed installation with frame

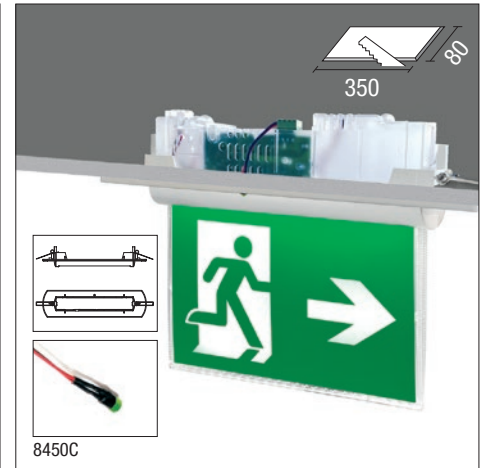

LED Compact															
Descrizione Description	Potenza* Power	Versione Version	Autonomia** Autonomy	Inibizione Inhibition	Batteria Battery Ni-Cd		Ricarica Recharge	Flusso medio Average flow		n°LED	Assorb. max W		Pcs	Codice Code	Euro
	W		h.	switch + rest mode	Volt	Ah	h.	SE lm	SA lm		SE	SA			
COMPACT IP42 24 SA-SE 3H AT C	24	SE SA	1(3)	SI	3,6	1,6	12	240	240	18	1,5	2,8	5	8450	140,00

*Potenza indicativa per il confronto con tubo fuoescente (a parità di lumen prodotti) - Indicative power for comparison with fluorescent tube (for equal lumens produced).
**Rimuovendo il Jumper interno si triplica l'autonomia e si riduce di 1/3 il flusso luminoso - Removing the internal Jumper, it triples the autonomy and reduces the luminous flux by 1/3

Indicatori LED Autodiagnosi - LED indicator Autotest

	☀ Fisso - Fixed light	☀ Lampeggiante - Flashed light	
Verde - Green	Batteria carica Battery charged	Batteria in carica Battery in charge	
Rosso - Red	Lampada guasta Lamp fail	Batteria guasta e / o autonomia insufficiente Battery fail and/or insufficient autonomy	
Arancio - Orange	Lampada inibita in assenza di rete Lamp inhibited in no mains condition	Inibizione test funzionale e di autonomia Functional and autonomy tests inhibited	

LED Compact

accessori non inclusi - *not included accessoires*

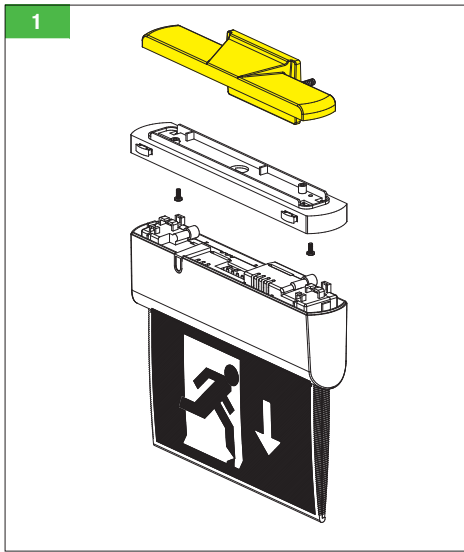

Codice Code	Descrizione Description	Euro
8450P	Installazione a parete con staffa parallela Wall mounting with parallel bracket	11,00

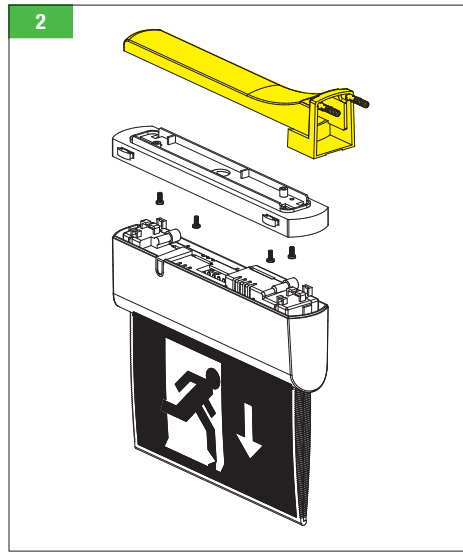

Codice Code	Descrizione Description	Euro
8450T	Staffa 90° per bandiera 90° bracket for double sided diffuser	11,00

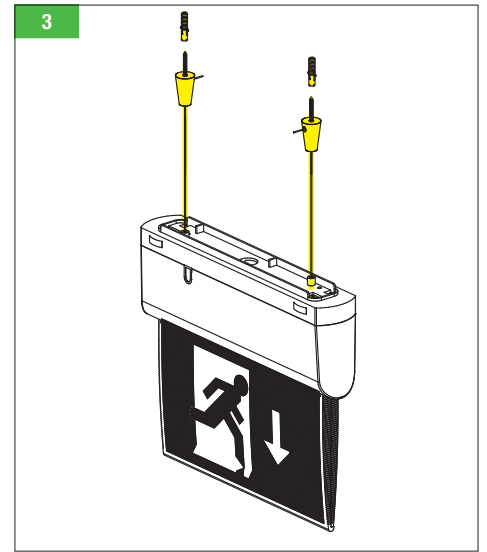

Codice Code	Descrizione Description	Euro
8450S	Kit per sospensione Suspension kit	21,00

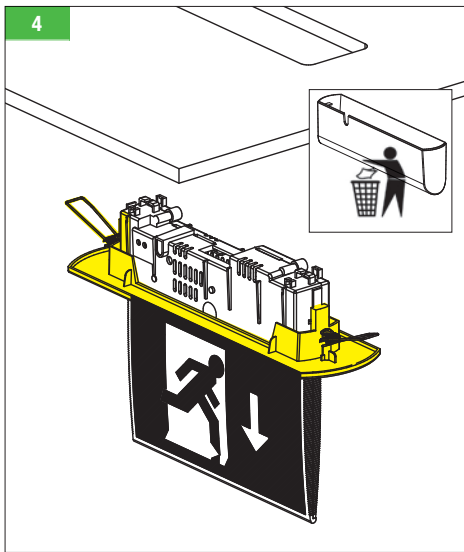

Codice Code	Descrizione Description	Euro
8450C	Installazione in controsoffitto False ceiling mounting	13,00

Dimensioni (mm) - Dimensions (mm)

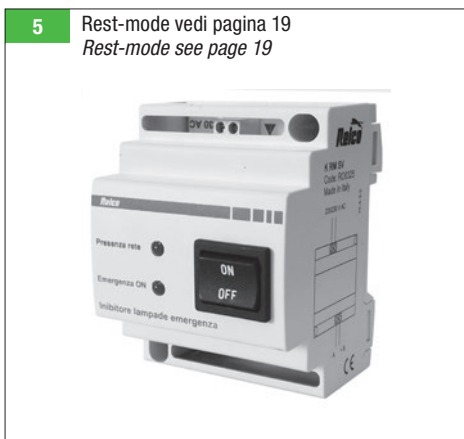
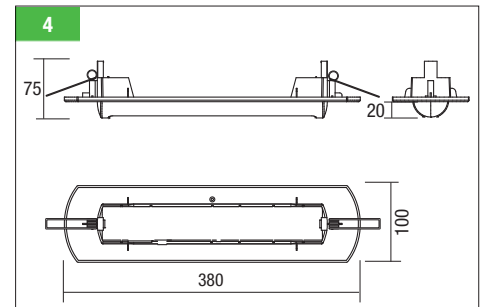
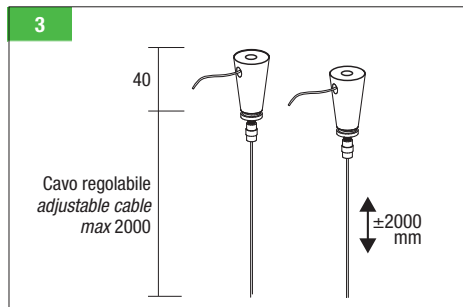
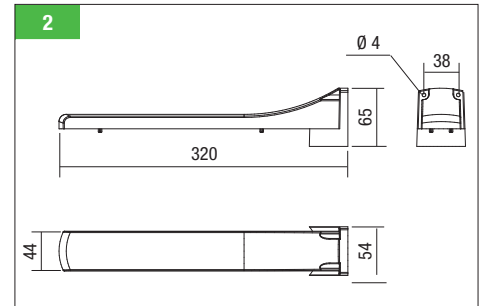
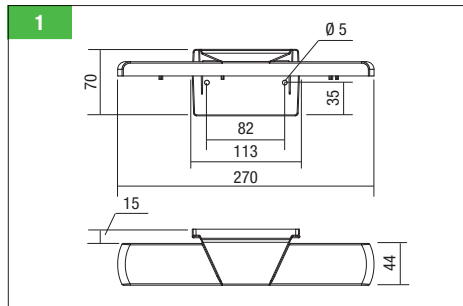

5 Rest-mode vedi pagina 19
Rest-mode see page 19



Segnaletica LED d'emergenza - Emergency LED signal

EMERGENCY