

# Sommario - Summary

Informazioni  
**IMPORTANTI**  
Very important  
**INFORMATION**

## Proiettori / Sospensioni - Floodlights



Pinguino serie  
Pag. 16



Puma serie  
Pag. 16



Tigre  
Pag. 24



BASICseries Virgola  
Pag. 28



Jaguaro  
Pag.



Milano Sport 1-2-3-4  
Pag.34



Lampo serie  
Pag. 41



Tunnel Evolution serie  
Pag. 49



Minizeus  
Pag. 52



Zeus  
Pag. 52



Milano Logistica  
Pag. 60



BASICseries - Punto serie  
Pag. 62



Zeus ATEX 2-22  
Pag. 64



AGP Evolution ATEX 2-22  
Pag. 66

## Apparecchi stagni - Waterproof luminaires



Allegra Plus  
Pag. 68



Allegra TOP  
Linea passante - Loop In - Loop out  
Pag. 72



BASICseries Allegra Basic  
Pag. 76



Pupilla sensor DIM  
Pag. 78



Allegra ATEX 2-22  
Pag. 80



Allegra Metal  
Linea passante - Loop In - Loop out  
Pag. 82

## Arredo urbano / Illuminazione stradale - Urban lighting / Street lighting



Lanterna  
Pag. 84



Pali luminosi  
Pag. 88



Lampione 2  
Pag. 92



Lampione 4  
Pag. 92



Lampione 6  
Pag. 92



Lampione 7  
Pag. 92



Lampione 8  
Pag. 92



Lampione 9  
Pag. 92



Lampione 10  
Pag. 92



Lampione 12  
Pag. 92

## Armature stradali - Street lights



Pali conici - Conical poles  
Pag. 102



Gardena  
Pag. 104



Sempione serie  
Pag. 108



Gran Sasso serie  
Pag. 116

## Lampade residenziali - Residential lights



Monza Round  
Pag. 121



Tuba Lux  
Pag. 124

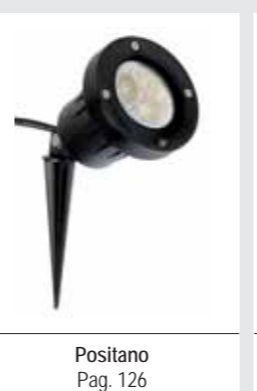

Positano  
Pag. 126



Gargano  
Pag. 127



Capri mini - Capri  
Pag. 128



Ischia serie  
Pag. 130



Ovest - Pag. 136



Cubo - Pag. 137



Nord  
Pag. 138



Maga serie  
Pag. 140



Asso Round 3 CCT  
Pag. 145



Asso Square 3 CCT  
Pag. 147

## Apparecchi per esterni residenziali - Outdoor luminaires



Su & Giù  
Pag. 148



Doppio Su & Giù  
Pag. 148



Micro Solo Giù Round  
Pag. 151



Medio Solo Giù Square  
Pag. 151



Sologliù R - Sologliù S  
Pag. 152



Mole 3 CCT  
Pag. 153



Up & Down  
Pag. 155



Lodi Giù  
Pag. 156



Turbot  
Pag. 158



Line Up  
Pag. 159



Platax serie  
Pag. 160



Luna Plena  
Pag. 166



BASICseries Kamaleon 3 CCT  
Pag. 168

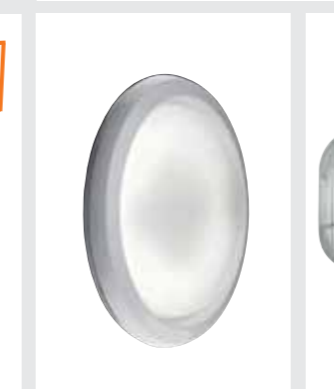

Aster  
Pag. 170



Plafoniere - Ceiling luminaires  
Pag. 171



Platax E27 serie  
Pag. 175

## Incassi residenziali - Residential recessed



Londra - Miami  
Pag. 176



Parigi  
Pag. 178



Nasca  
Pag. 180



Venezia  
Pag. 182



Rondo  
Pag. 184



Naasby R  
Pag. 187



Naasby O  
Pag. 187



Firenze  
Pag. 188



Monocilindrico  
Pag. 190



Radiante  
Pag. 192



Rdente  
Pag. 194



Monza Round Wall Washer RGBW  
Pag. 198

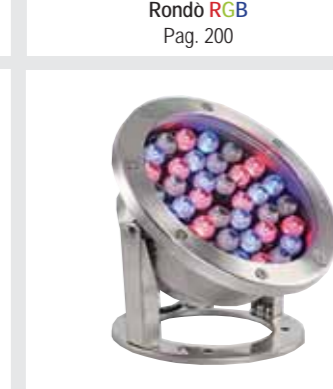

Rondo RGB  
Pag. 200



Gargano RGB  
Pag. 202

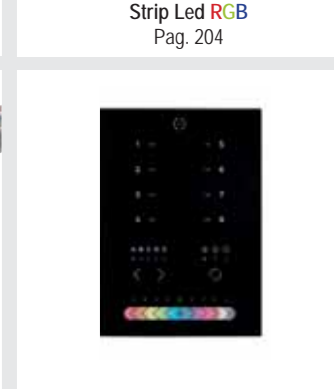

Strip Led RGB  
Pag. 204



Lampo RGBW  
Pag. 206



Lince RGBW  
Pag. 208



Accessories RGB  
Pag. 211



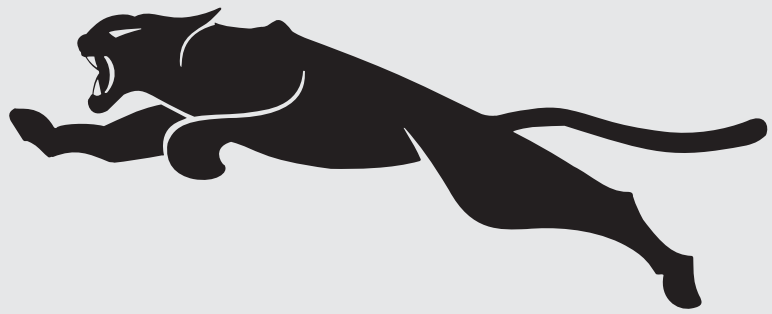

Nasce nel 1967 dalla passione e dall'ingegno di Giuseppe Pisati e oggi dai suoi nipoti Joseph, Julius e Jodie.

Il solido know-how nel campo della componentistica ha permesso a **Relco** di andare oltre, sviluppando una propria linea di apparecchi di illuminazione, da utilizzare sia in outdoor che indoor. Molti dei nostri progetti sono consultabili nel sito:

[www.relcogroup.com](http://www.relcogroup.com)

It was born in 1967 from the passion and ingenuity of Giuseppe Pisati and today from his grandchildren Joseph, Julius and Jodie.

The solid know-how in the field of components has allowed Relco to go further, developing its own line of lighting fixtures, to be used both indoors and outdoors. Many of our projects can be consulted on the site:

[www.relcogroup.com](http://www.relcogroup.com)



## SERVIZIO AL CLIENTE - SERVICE FOR THE CUSTOMERS



### Consulta il nostro sito ottimizzato per tablet e smartphone

Dovunque tu sia potrai avere informazioni dettagliate su: prodotti, punti vendita, informazioni tecniche e commerciali, e potrai effettuare il download di cataloghi, schede tecniche e listini aggiornati in tempo reale.

[www.relcogroup.com](http://www.relcogroup.com)

### Check out our website designed for tablets and smartphones

Wherever you are, you will be able to access detailed information on: products, outlets, technical and marketing information, and you will be able to download catalogues and price lists updated in real time.



### Progettazione

La certificazione fotometrica dei nostri apparecchi viene sempre effettuata da un laboratorio fotometrico esterno. Efficienza luminosa e "lm Output" sono quindi il risultato di un ente terzo in alcun modo vincolato a Relco S.r.l. I progetti illuminotecnici sviluppati da Relco mettono a disposizione dei clienti le soluzioni più efficaci per esigenze spesso molto complesse. La definizione di ogni progetto determina un'autentica partnership tra le parti. La nostra realtà è a completa disposizione di progettisti che realizzano lavori con un alto profilo tecnologico: [projects@relcogroup.com](mailto:projects@relcogroup.com)

### Project

The lumen output performance of our lighting fixtures is always tested by third party accredited laboratories. The fixture efficiency and lm output are the results attested by a third party laboratory which is not bonded to Relco S.r.l. The lighting projects developed by Relco make the most efficient solutions to very complex issues available to customers. Defining each project results in an authentic partnership between the parties. Our company is at the full service of designers working on highly technological projects: [projects@relcogroup.com](mailto:projects@relcogroup.com)

## Confort visivo - Visual confort



### Controllo dell'abbagliamento

L'illuminazione degli spazi operativi in un'ottica smart, deve essere in grado di migliorare il senso di benessere di chi lavora seguendo le necessità degli utenti finali.

I sistemi di regolazione di **RELCO** consentono di trovare il giusto equilibrio tra luce artificiale e luce naturale proveniente dall'esterno.

Ciò consente di dare sostegno al bioritmo umano e creare le migliori condizioni visive per ogni attività.

Un ambiente confortevole sotto il profilo illuminotecnico incoraggia la creatività delle persone che lo abitano.

Relco offre soluzioni illuminotecniche globali, in grado di offrire valore aggiunto all'unione tra luce e architettura.

Ampia scelta di apparecchi LED e sistemi di comando per le applicazioni più svariate dell'illuminazione professionale di: uffici e istituti didattici, negozi, hotel e wellness, salute e cura, arte e cultura, industria e tecnica.

Relco sa trovare il giusto equilibrio fra qualità della luce ed efficienza energetica sviluppando soluzioni illuminotecniche su misura.

**Veniamo incontro alle vostre esigenze specifiche e alle necessità degli utenti, senza mai perdere di vista l'obiettivo di trovare la luce migliore per l'uomo e per l'ambiente.**

### Glare control

*The lighting of the work areas from a smart perspective must be able to improve the well-being of those who work according to the needs of end users.*

*The RELCO regulation systems allow the right balance to be found between artificial light and natural light coming from outside.*

*This allows us to support human biorhythm and create the best visual conditions for any activity.*

*A comfortable environment in terms of lighting encourages the creativity of the people who live in it.*



*Relco offers global lighting solutions, able to offer added value to the combination of light and architecture.*

*A wide selection of LED fixtures and control systems for various professional lighting applications: offices and educational institutions, shops, hotels and wellness, health and care, art and culture, industry and engineering.*

*Relco knows how to find the right balance between quality of light and energy efficiency by developing customised lighting solutions.*

***We meet your specific needs and users' needs, without ever taking our eyes off the goal of finding the best light for humans and the environment.***

### UGR<... Classificazione valori UGR in funzione delle applicazioni. UGR value classification based on application.

 <b>UGR≤16</b>	<b>Applicazioni molto impegnative</b> (disegni tecnici, lavoro a videoterminale). <b>Highly demanding applications</b> (technical drawings, working with video display terminals).
 <b>UGR≤19</b>	<b>Uffici e scuole</b> (lettura, scrittura, riunioni). <b>Offices and schools</b> (reading, writing, meetings).
 <b>UGR≤22</b>	Applicazioni industriali, artigianato. <b>Industrial, artisanal applications.</b>
 <b>UGR&gt;28</b>	Abbagliamento elevato. <b>High glare.</b>

#### Fattore di abbagliamento UGR<19

Valore contemplato secondo la norma  
(coefficiente di riflessione: soffitto 0,7 - pareti 0,5).

#### Factor glare UGR<19

Value calculated according to the standard  
(reflection coefficient: ceiling 0.7 - walls 0.5)

L'UGR è l'indicatore dell'abbagliamento diretto derivante dall'impianto di illuminazione.

La norma Europea per l'illuminazione dei posti di lavoro in interni **UNI-EN12464-1** richiede un valore UGR specifico per ogni applicazione, compreso tra 10 e 30. Più è basso il valore, minore è l'abbagliamento.

Il valore esatto di tale indice è da calcolare su progetto in quanto dipende dalla disposizione degli apparecchi illuminanti, dalle caratteristiche dell'ambiente (dimensioni, riflessioni) e dal punto di osservazione.

*UGR is the indicator to assess the direct glare coming from a lighting system.*

*The UNI-EN12464-1 European standard for lighting indoor workplaces requires a specific UGR value for every application, ranging between 10 and 30. The lower the value, the lower the glare.*

*The exact value of this rating must be calculated in the design, as it depends on how the lighting fixtures are arranged, the features of the space (dimensions, reflections), and the viewpoint.*



## Prestazioni di alto livello - High level performances

### Aspettativa di vita del LED e suo decadimento LED service life expectancy and deterioration

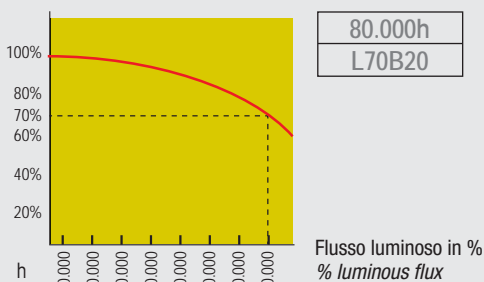

I LED diminuiscono gradualmente il loro flusso luminoso iniziale fino ad esaurirsi completamente in un periodo molto lungo. La durata di vita utile, indica la percentuale di decadimento del flusso luminoso (parametro "L") riferita ad un numero di ore utili di funzionamento. Il parametro "B" seguito da un valore normalmente compreso tra 10 e 50, indica la percentuale di componenti che, raggiunte le ore utili di funzionamento, non mantengono le caratteristiche di flusso luminoso dichiarate; ad esempio 80000h L70B20 vuol dire che l'80% dei moduli LED fornisce il 70% del flusso luminoso iniziale dopo 80000h di funzionamento.

The drop in LED flux is represented by acronym L70, which means flux at 70%. Value (B) followed by a value between 10 and 50 indicates the quality of the component being used, defining the percentage of LED that maintain the declared characteristics when the 80,000 hours have elapsed. Declared LED (L70B20) indicates that when 80,000 hours have elapsed, 80% (B20) of the LEDs have 70% of the flux they had at the beginning of their service life.

### Pittogramma Low Flicker Low Flicker pictogram



Apparecchio con flicker molto basso  
Product with a very low flicker

Flicker indica lo sfarfallio visibile a occhio nudo. Può verificarsi a frequenze inferiori a 60hz e dipende da diversi fattori tra cui il ripple di uscita degli alimentatori. E' importante definire "low" non vuol dire esente, ma ridotto.

Flicker is a common issue with LED lamps. It can occur at frequencies below 60 Hz and depends on several factors, such as the ripple emitted by drivers. Furthermore, "flicker-free" does not mean "without" but rather "very low".

### RIPPLE FREE

Il **RIPPLE FREE** è un esempio dello sviluppo e ricerca sui prodotti Relco Lighting & Components. I driver LED Relco Lighting & Components sono forniti di un circuito multistadio per alimentare i LED con una corrente perfetta. Con il termine RIPPLE si fa riferimento alla dimensione della forma d'onda della corrente d'uscita del driver LED. Dove il ripple è presente la forma d'onda si deforma con conseguente surriscaldamento del LED che ne riduce la vita media. Inoltre il ripple, causa oscillazioni della luce provocando disturbi durante le riprese video. Sullo schermo verranno visualizzate una serie di righe scure in movimento verso il basso che renderanno l'immagine illeggibile. Quando si alimentano i LED con LED Driver RIPPLE FREE è possibile raggiungere le massime prestazioni ed efficienza luminosa, con la minima dissipazione di calore.

The **RIPPLE FREE** is an example of R&D on the Relco Lighting & Components products. The Relco Lighting & Components LED drivers are provided with multistage circuit to feed the LEDs with a perfect current. The term RIPPLE refers to the dimension of the wave form of the LED driver output current, when present this deforms the same wave form with consequent overheating of the LED with reduced average life. Also this phenomenon, cause of light oscillations, results in effects while shooting videos, where the images appear to be cut with several black lines making shooting impossible. When you feed the LEDs with Led driver RIPPLE FREE you can achieve maximum performance and light efficiency, with minimal heat dissipation.

### Norme Europee di certificazione elettrica European norms electrical certification

**CE** Tutti i prodotti sono costruiti nel rispetto delle Normative Europee (2014/35/UE, 2006/95/CE, 2014/30/UE, 2004/108/CE, 2009/125/CE) come riportato nella dichiarazione di conformità UE.

All products are manufactured in compliance with European Directives (2014/35/UE, 2006/95/CE, 2014/30/UE, 2004/108/CE, 2009/125/CE) as reported in the UE conformity declaration.

### Sicurezza fotobiologica Photobiological safety



La sicurezza fotobiologica è determinata dalla quantità di radiazioni emesse dalle sorgenti luminose con lunghezza d'onda compresa tra 200nm e 3000nm.

Un'esposizione eccessiva alle radiazioni, può essere causa di danni per l'uomo. La norma EN62471 definisce una classificazione delle sorgenti in gruppi di rischio. RG0 Ethr: apparecchi che non presentano rischio fotobio-logico ai fini della Norma EN62471. Richiedere in sede la distanza dal punto di osservazione, se necessaria.

RG0: assenza di rischi fotobiologici ai fini della norma EN62471.

RG1 (gruppo di rischio basso): la sorgente non provoca rischi dovuti a normali limitazioni di funzionamento sull'e-sposizione.

RG2 (gruppo di rischio moderato): la sorgente non pro-voca un rischio in seguito ad una reazione istintiva guar-dando fonti molto luminose o in seguito ad una sensazio-ne di disagio termico.

We often read about photo-biological safety in lighting design. This very important factor is determined by the amount of radiations emitted by all the sources with a wave length ranging between 200 nm and 3000 nm. Excessi-ve radiation exposure can be harmful for human health. The EN62471 standard classifies light sources into risk groups. Risk Group 0 (RG0 Ethr): luminaires are exempt from photobiological risks in compliance with standard EN 62471. If necessary, contact our customer service for the observation distance.

RG0 (exempt risk group): the lighting source is exempt from risks in compliance with EN 62471 Standard.

RG1 (low risk group): no risk deriving from a limited emission of radiation.

RG2 (moderate risk): the lighting source does not pose hazards because of our aversion response to very bright light sources, or due to the fact that we would experien-ce thermal discomfort.



ENEC è un Marchio Europeo di Certificazione di prestazione, è stato istituito in sede CENELEC (Comitato europeo di normazione elettrotecnica) dagli organismi di certificazione elettrica che hanno aderito ad un accordo denominato "LUM AGREEMENT" per il mutuo riconoscimento di un unico marchio "ENEC" equivalente ai singoli marchi degli organismi aderenti. ENEC è un marchio ad alto valore tecnico basato su severi criteri di certificazione che offre garanzie oltre che sulla sicurezza elettrica anche sulle prestazioni dell'apparecchio elettrico. A fianco del marchio ENEC viene posto un numero che identifica l'organismo che ha rilasciato la certificazione.

ENEC is a European Certification mark for performance established at CENELEC (European Committee for Electrotechnical Standardization) by electrical certification institutions. These bodies have entered an agreement called "LUM AGREEMENT" for the mutual recognition of a sole mark, "ENEC", equivalent to the single marks of the adhering institutions. ENEC is a high value technical mark based on strict certification criteria which offers a guarantee not only on electrical safety but also on the performance of the electrical apparatus.

### Certificazioni ISO 9001 ISO 9001 certification





# Protezione - Protection

## Cos'è la sovratensione? What is a surge?

È un rapido innalzamento del valore di tensione tra parti di diverse polarità e tra queste e la terra.

Alcune sovratensioni possono superare la soglia d'isolamento o di immunità dei componenti elettronici provocandone il disservizio.

*A surge is a rapid increase in voltage on a power line between parts of opposite polarities and/or the ground. Some power surges may exceed the isolation or immunity threshold of electronic components causing it to fail.*

## Dispositivi di protezione Surge protector

Per fare fronte ai danni causati da sovracorrenti o sovratensioni viene utilizzato un dispositivo di protezione conforme alla norma EN 61547 contro i fenomeni impulsivi atto a proteggere il modulo LED e il relativo alimentatore.

*To protect lighting installations from surge, i.e. the rapid increase in voltage between parts of opposite polarities and/or the ground, Relco Components & Lighting has equipped its luminaires with an EN 61547 compliant surge protector, capable of protecting the LED module and their related driver from voltage spikes, damages caused by lightning and overcurrents.*

## Modalità di protezione Protection modes

**Modo differenziale:** Surge tra i conduttori di alimentazione, tra il conduttore di sovratensione verso quello di neutro. Sostanzialmente, tra fase (L) e neutro (N) non si presentano sovratensioni molto elevate perché i picchi di tensione vengono soppressi da altre apparecchiature collegate alla rete elettrica; di conseguenza è sufficiente una protezione più bassa da sovratensione. A seconda della famiglia di prodotto, Relco Lighting & Components integra quindi una protezione fino a 6 kV.

**Modo comune:** Surge tra i conduttori di alimentazione, L/N, verso la terra o il corpo dell'apparecchio se quest'ultimo è in classe II (se questo è installato su palo metallico). Le sovratensioni di modo comune sono ad esempio generate dai fulmini, e possono raggiungere valori molto elevati. A seconda della famiglia di prodotto, Relco Components & Lighting integra una protezione fino a 8 kV (a richiesta 10kV).

**Differential mode:** Surge between power conductors, between the phase conductor to the neutral conductor. Substantially, between phase (L) and neutral (N) no substantial surges are present because voltage peaks are suppressed by other equipment connected to the power line; as a consequence a lower surge protector is sufficient. Depending on the type of product, Relco Lighting & Components provides a protection from surges of up to 6kV

**Common mode:** Surge between power conductors, L/N, to the ground or the body of the luminaire if it is classified in class II (i.e. it is installed on a metal pole). Overvoltage in the common mode are generated by lightning strikes and may reach very high levels. Depending on the type of product, Relco Lighting & Components provides a protection from surges of up to 8 kV (10kV upon request).

## Gli effetti delle sovratensioni The effects of surges

Sovratensioni di ridotta entità non comportano necessariamente l'immediato guasto di moduli LED o driver (se pur con protezione 4kV), se però si verificano ripetutamente possono provocare il deterioramento precoce dei LED e, di conseguenza, una durata ridotta. Sovratensioni elevate (caduta dei fulmini) si traducono invece nel guasto immediato dei moduli LED o dei driver. Nei moduli LED e nei driver le sovratensioni provocano correnti elevate (impulsi di energia). Questo fenomeno può provocare:

- guasto parziale o totale dei moduli LED o dei driver
- deterioramento accelerato dei moduli LED diminuendone la durata
- possibile guasto anche dell'interfaccia di comando

*Small overvoltages do not necessarily lead to the immediate failure of LED modules or drivers (albeit with 4kV protection), but if they occur repeatedly they can cause premature deterioration of the LEDs and, consequently, a shortened life span. High overvoltages (lightning strikes), on the other hand, result in immediate failure of the LED modules or drivers. In LED modules and drivers, overvoltages cause high currents (energy pulses). This phenomenon can cause:*

- partial or total failure of the LED modules or drivers
- accelerated deterioration of the LED modules reducing their duration
- possible failure of the command interface as well



## Riprese televisive con illuminazione a LED TV footage with LED lighting

Durante una trasmissione televisiva, si può notare un fastidioso sfarfallio delle immagini a rallentato. Il fenomeno di "flicker", affatica la vista e distrae lo spettatore. Le cause dello sfarfallio possono essere: frequenza della modulazione, fluttuazione di tensione e numero di fotogrammi al secondo. Generalmente uno sfarfallio inferiore al 5% non da alcun fastidio durante le riprese fino a 150 fotogrammi al secondo. Un sistema di illuminazione con un fattore di sfarfallio (FF) inferiore a 5% è in grado di eliminare il disturbo percepito.

*During a broadcast it is not uncommon to perceive an annoying flicker especially during slow motion. This flicker is distracting and should be eliminated where possible. The circumstances that produce the flicker vary upon the frequency modulation, voltage and camera frame rate. The table below provides a general rule of flicker factor values produced by various lighting systems. A flicker factor of less than 5% will generally not cause problems for slow motion replays at up to 150 frames per second. A lighting system with a flicker factor of less than 5% will eliminate the perceived flicker at most frame rates per second used within the sports television industry. The acceptable level of flicker factor (FF) is indicated in the Illuminance Category Tables.*

Tabella dei valori Flicker Factor (FF)	
Tipo di illuminazione	Valore FF (indicativo)
Luce naturale	0%
Apparecchi LED. La % di sfarfallio dipende dal tipo di LED e alimentatore utilizzati	< 3%
Lampade a scarica con alimentatori ad alta intensità	< 4%
Lampade a scarica con alimentatori magnetici trifase in grado di emettere luce uniforme	8 - 20%
Lampade a scarica con alimentatori elettromagnetici monofase	30 - 50%

Flicker Factor reference table (FF)	
Lighting type	FF value (indicative)
Daylight	0%
LED Luminaires % of flicker depend upon the type of LED power supply	< 3%
Discharge lamps with high frequency ballasts	< 4%
Discharge lamps with 3-phase magnetic ballasts for uniform light	8 - 20%
Discharge lamps with single-phase magnetic ballasts	30 - 50%

# Protezione IP - IP Protection

Schema relativo alle cifre che compongono il grado IP	
<b>Significato relativo alla prima cifra del grado di protezione</b>	
1	Protezione da oggetti solidi maggiori di 50mm
2	Protezione da oggetti solidi maggiori di 12mm
3	Protezione da oggetti solidi maggiori di 2,5mm
4	Protezione da oggetti solidi maggiori di 1mm
5	Protezione da polveri
6	Protezione forte da polveri
<b>Significato relativo alla seconda cifra del grado di protezione</b>	
1	Protezione da gocce d'acqua
2	Protezione da gocce d'acqua deviate fino a 15°
3	Protezione da vapori d'acqua
4	Protezione da spruzzi d'acqua
5	Protezione da getti d'acqua
6	Protezione da getti d'acqua forti o mareggiate
7	Protezione contro l'immersione
8	Protezione contro l'immersione continua
Questo semplice schema ci suggerisce quindi che qualsiasi prodotto di illuminazione dovrà essere scelto in base al suo grado di protezione IP. Tale grado sarà il risultato della valutazione delle caratteristiche del luogo di installazione del medesimo prodotto e del suo impiego.	

<i>Diagram of the numbers that make up the IP rating</i>	
<b>Meaning of the first numbers of the protection rating</b>	
1	<i>Protection from solid objects larger than 50 mm</i>
2	<i>Protection from solid objects larger than 12 mm</i>
3	<i>Protection from solid objects larger than 2.5 mm</i>
4	<i>Protection from solid objects larger than 1 mm</i>
5	<i>Protection from dust</i>
6	<i>Strong protection from dust</i>
<b>Meaning of the second numbers of the protection rating</b>	
1	<i>Protection from dripping water</i>
2	<i>Protection from dripping water when tilted up to 15°</i>
3	<i>Protection from spraying water</i>
4	<i>Protection from splashing water</i>
5	<i>Protection from water jets</i>
6	<i>Protection from powerful water jets or sea storms</i>
7	<i>Protection from immersion</i>
8	<i>Protection from continuous immersion</i>
<i>This simple diagram suggests that any lighting fixture must be chosen based on its IP rating. This rating will be the result of an assessment of the characteristics of the place of installation of the product itself and of its use.</i>	

<b>Esempi di IP presenti su alcuni apparecchi per interni ed esterni</b>	
IP44	Il grado IP 44 garantisce la protezione contro la penetrazione di corpi solidi maggiori di 1 mm. Permette la protezione contro la penetrazione di liquidi da gocce, vapori o spruzzi in qualsiasi direzione
IP54	Il grado IP54 garantisce la protezione totale alla penetrazione di corpi solidi, di liquidi da gocce, vapori o spruzzi in qualsiasi direzione. Questo grado di isolamento non permette la penetrazione di polveri e liquidi non deve danneggiare l'apparecchiatura
IP55	Il grado IP55 garantisce la protezione totale alla penetrazione di corpi solidi, la penetrazione di liquidi da gocce, vapori, spruzzi e getti d'acqua in qualsiasi direzione. Inoltre non deve permettere la penetrazione di polveri e liquidi non deve danneggiare l'apparecchiatura.
IP65	Il grado IP65 garantisce la protezione totale alla penetrazione di corpi solidi, la penetrazione di liquidi da gocce, vapori, spruzzi e getti d'acqua in qualsiasi direzione. In questo grado di protezione, la penetrazione liquidi non deve danneggiare l'apparecchiatura
IP66	Il grado IP66 è garanzia di protezione totale alla penetrazione di corpi solidi e polveri, di penetrazione di liquidi da spruzzi, mareggiate e forti getti d'acqua in qualsiasi direzione. Anche in questo caso la penetrazione liquidi non deve danneggiare l'apparecchiatura
IP67	Il grado IP67 garantisce la protezione totale alla penetrazione di corpi solidi e polveri, la protezione contro l'immersione in acqua momentanea per 30 minuti a 1 metro di profondità.
IP68	Il grado IP68 permette una protezione totale alla penetrazione di corpi solidi e polveri, contro l'immersione in acqua permanente a 1 metro di profondità.
IP68-xx	Il grado IP68-XX permette una protezione totale alla penetrazione di corpi solidi e polveri, contro l'immersione in acqua permanente a xx metri di profondità

<b>Examples of IPs present on some indoor or outdoor lamp</b>	
IP44	<i>The IP 44 rating ensures protection from penetrating solid bodies greater than 1 mm. It also ensures protection from dripping, spraying and splashing water in any direction</i>
IP54	<i>The IP 54 rating ensures complete protection from penetrating solid bodies as well as dripping, spraying and splashing water in any direction. This insulation rating ensures protection from dust ingress and penetrating liquids which must not damage the equipment.</i>
IP55	<i>The IP 55 rating ensures complete protection from penetrating solid bodies as well as from dripping, spraying, splashing water and water jets in any direction. Moreover, it must protect from dust ingress and penetrating liquids which must not damage the equipment</i>
IP65	<i>The IP 65 rating ensures complete protection from penetrating solid bodies as well as dripping, spraying, splashing water and water jets in any direction. With this insulation rating, penetrating liquids must not damage the equipment.</i>
IP66	<i>The IP 66 rating ensures complete protection from penetrating solid bodies and dust ingress, as well as from dripping, spraying, splashing water, sea storms and strong water jets in any direction. In this case as well, penetrating liquids must not damage the equipment</i>
IP67	<i>The IP67 rating ensures complete protection from penetrating solid bodies and dust ingress, and from temporary immersion in water for 30 minutes at a depth of 1 metre</i>
IP68	<i>The IP68 rating ensures complete protection from penetrating solid bodies and dust ingress, from permanent immersion in water at a depth of 1 metre</i>
IP68-xx	<i>The IP68-xx rating ensures complete protection from penetrating solid bodies and dust ingress, from permanent immersion in water at a depth of xx metres</i>



## Sistemi di controllo Control systems

1-10Vdc

Controllo dell'illuminazione in modo facile, elegante ed energeticamente efficiente con un dimming continuo. Permette una riduzione dei costi dell'illuminazione e del consumo di energia. Per tutti i componenti necessari vi consigliamo di fare riferimento al catalogo Relco Components scaricabile dal sito.

*Easy access mode for controlling the illumination, elegant and energy-efficient through a continuous dimming. It permits a sensible cost-reduction of the illumination energy-consume. For all required components, please refer to the Relco Components catalogue which can be downloaded from the website.*



### Digital Address Lighting Interface

La regolazione mediante l'interfaccia digitale DALI (Digital Addressable Lighting Interface) rappresenta l'evoluzione della regolazione analogica. Questa interfaccia è stata sviluppata comunemente dai più importanti produttori di alimentatori elettronici per realizzare uno standard di regolazione comune all'industria mondiale illuminotecnica.

#### Caratteristiche principali della REGOLAZIONE DALI

- Memorizzazione di scenari luminosi;
- Messaggi per lampada guasta o a fine vita;
- Nessun problema con le fasi della rete;
- Nessuna necessità di rispettare la polarità dei cavi di regolazione;
- Possibilità di assegnare un indirizzo univoco ad ogni dispositivo connesso.

*Regulation by means of DALI (Digital Addressable Lighting Interface) digital interface represents an evolution in analogical regulation. This interface has been jointly developed by the most important producers of electronic drivers to create a standard regulation for the lighting engineering industry all over the world.*

#### Main features of the DALI REGULATION

- Memory function of light scenes;
- Messages for breakdown or end of life of the lamp;
- No problem with the phases of the supply mains;
- No need to observe the polarity of the regulation cables;
- Possibility to assign a unique address to each connected device.



Sistema di controllo con l'utilizzo di pulsanti standard per la gestione della tensione di rete al fine di regolare il flusso luminoso. Con una breve pressione si potranno accendere, spegnere e regolare i driver collegati. Il funzionamento può essere effettuato da più punti. Soluzione integrabile con sensore di luce.

*Control system with the use of standard buttons for managing the mains voltage in order to adjust the luminous flux. With a short press the connected drivers can be switched on, off and adjusted. Operation can be carried out from several points. Solution that can be integrated with light sensor.*

Wireless



Sistema di controllo puntuale dell'impianto mediante tecnologia senza la necessità dell'installazione di cavi elettrici.

La gestione è possibile mediante telecomando e/o smartphone.

*Thorough installation control system via technology not requiring electrical cables to be laid.*

*Management is possible via remote control and/or smartphone.*



DMX

Protocollo per illuminazione dinamica.

Il tempo di reazione è immediato e il numero di apparecchi che si può controllare è praticamente illimitato. DMX può essere utilizzato anche per la dimmerazione delle luci di impianti sportivi.

DMX consente un'intera gamma di effetti scenici; il monitoraggio di ogni apparecchio di illuminazione e una configurazione facile da eseguire attraverso le funzioni DMX autoindirizzanti.

*Dynamic lighting protocol.*

*The reaction time is immediate and the number of devices that can be controlled is practically unlimited. DMX can also be used for dimming the lights of sports facilities.*

*DMX allows a whole range of scenic effects; the monitoring of each luminaire and an easy configuration through the self-addressing DMX functions.*



#### Sensori di luminosità/presenza

Consentono un utilizzo intelligente della luce di spazi altrimenti difficilmente gestibili, ottenendo così importanti risparmi di energia.













L'uso dei sensori è consigliato in ambienti in cui vi sia un'occupazione saltuaria o dove è necessario un livello di illuminamento costante.















#### Brightness/presence sensor

*They do permit a very flexible utilization of the light in difficulties spaces, handled by a stable concept of illumination.*

*In addition, they do permit the easy handling and control of the in line with the different needs, obtaining important energy saving.*

# Legenda simboli - Symbols legend

colour	Colore apparecchio - <i>Surface finish</i>
W	Watt
pcs	Quantità minima ordinabile - <i>Minimum quantity to be ordered</i>
Kg	Peso netto in Kg del prodotto - <i>Net product weight in Kg</i>
A	Ampere
Hz	Frequenza - <i>Frequency</i>
V	Volt
colour	Colore apparecchio - <i>Lamp colour</i>
time/flux	Autonomia/flusso - <i>Duration/flux</i>
LED	Tipo di LED - <i>LED type</i>
S	Corpo apparecchio - <i>Body</i>
S + L	Corpo apparecchio + lampada - <i>Body + bulb</i>
CELL	Corpo apparecchio + alimentazione elettronica + scheda LED <i>Body + driver + circuit LED</i>
CELL-E	Corpo apparecchio + alimentazione elettronica + lampada + emergenza <i>Body + driver + Bulb + emergency kit</i>
Art. S	Installazione a sospensione <i>Suspended installation</i>
Art. R	Installazione ad incasso <i>Recessed installation</i>
Art. C	Installazione a plafone <i>Ceiling installation</i>
	Rotazione dell'apparecchio sull'asse verticale e orizzontale <i>Rotation of the device on the vertical and horizontal axis</i>
	Dotato di vetro di protezione temperato <i>Equipped with tempered protection glass</i>
	Apparecchio costruito con materiali riciclabili <i>This device is made of recyclable materials</i>
	Apparecchio che resiste alla prova del filo incandescente <i>The device passes the glow wire test</i>
	Con isolamento funzionale in ogni parte e terminale o morsetto di terra se fisso <i>With functional isolation in each part and terminal or ground clamp if fixed</i>
	Con doppio isolamento, senza dispositivi per la messa a terra <i>With double insulation, without ground devices</i>
	Apparecchio in bassa tensione di sicurezza. <i>Safety low voltage device.</i>
	Temperatura ambiente di funzionamento - <i>Operating ambient temperature</i>
	Indice di Resa Cromatica <i>Color Rendering Index</i>
	Apparecchi calpestabili e/o carrabili con bassa emissione di calore sul diffusore. <i>Walkover or/and drive over fitting with low heat emission on the diffuser</i>
	HIGH EFFICIENCY
	Prodotto dotato di kit d'emergenza <i>Article with emergency kit</i>
Lm/W	Efficienza lm/W apparecchio - <i>Efficiency lm/W unit</i>

nominal Im tc = 25°C	Efficienza della sorgente luminosa - <i>Efficiency of the light source</i>
lm output *	Efficienza luminosa effettiva dell'apparecchio <i>Effective luminous efficiency of the fixture</i>
	Prodotto con certificazione CB <i>Product with CB certificate</i>
	Prodotto conforme alle direttive D.M. 11 Ottobre 2017 <i>In compliance with the directives D.M. 11 Ottobre 2017</i>
	Dimensioni foro incasso <i>Hole for fitting dimensions</i>
IP	Resistenza dell'apparecchio alla penetrazione di liquidi o solidi <i>Devices resistance to the penetration of liquids or solids</i>
IK	Grado di resistenza agli urti <i>Impact resistance degree</i>
	LED COB full color
	LED SMD singol color
	Resistenza dell'apparecchio alla penetrazione di liquidi o solidi <i>Devices resistance to the penetration of liquids or solids</i>
	LED COB FULL COLOR
K	Temperatura di colore in Kelvin <i>Kelvin colour temperature</i>
3000K	Temperatura di colore in Kelvin - luce calda <i>Kelvin color temperature - warm white</i>
4000K	Temperatura di colore in Kelvin - luce neutra <i>Kelvin color temperature - day lights</i>
6000K	Temperatura di colore in Kelvin - luce fredda <i>Kelvin color temperature - cool lights</i>
	A richiesta 4000K <i>On request 4000K</i>
	A richiesta 6000K - <i>On request 6000K</i>
1-10Vdc	Controllo dell'illuminazione in modo facile, con un dimming continuo. <i>Easy access mode for controlling the illumination, a continuous dimming.</i>
	Sistema di controllo della luminosità attraverso pulsanti NA  <i>Brightness control system through NO buttons </i>
	Driver incluso nel prodotto <i>Driver included in the product</i>
	Driver non incluso, da ordinare a parte <i>Not included driver, to be ordered separately</i>
	<b>Tutti gli apparecchi di illuminazione di questo catalogo utilizzano un Driver LED "MULTIPOWER". A richiesta, per quantità, è possibile cambiare in fabbrica la taratura della corrente e, di conseguenza potenza (W) e Lumen (Lm)</b>  <i>All the luminaires in this catalog use a "MULTIPOWER" LED Driver. On request, for quantity, it is possible to change the current calibration in the factory and, consequently, power (W) and Lumen (Lm)</i>
Il flusso luminoso uscente dall'apparecchio viene indicato con una tolleranza di ± 10%. <i>The luminous flux exiting the fixture is indicated with a tolerance of ± 10%.</i>	















\* Lm Output

La certificazione fotometrica dei nostri apparecchi viene sempre effettuata da un laboratorio fotometrico esterno. Efficienza luminosa e Lumen Output sono quindi il risultato di un ente terzo, in alcun modo vincolato a Relco S.r.l. Il Flusso luminoso output riportato indica il flusso uscente dell'apparecchio di illuminazione con una tolleranza ± 10% rispetto al valore indicato.  
*The photometric certification of our appliances is always carried out by an external photometric laboratory. Luminous efficiency and Lumen Output are therefore the result of a third party, in no way bound to Relco S.r.l. The reported output luminous flux indicates the output flux of the lighting fixture with a tolerance of ± 10% compared to the indicated value.*



# Legenda simboli - Symbols legend

Applicazione apparecchi - <i>Appliance application</i>	
	Adatto per installazione in luoghi di culto. <i>Suitable for installation in places of worship.</i>
	Adatto per installazione in Hotel, Alberghi e luoghi di soggiorno. <i>Suitable for installation in hotels and places to stay.</i>
	Adatto per installazione in aule scolastiche. <i>Suitable for installation in classrooms.</i>
	Adatto per installazione in uffici con stazionamento di addetti a videoterminale. <i>Suitable for installation in offices with employees working at video terminals.</i>
	Adatto per installazione in uffici, corridoi, sale riunioni. <i>Suitable for installation in offices, corridors, meeting rooms.</i>
	Adatto per installazione in palestre, centri sportivi. <i>Suitable for installation in gyms, sports centres.</i>
	Adatto per illuminazione di opere d'arte, quadri. <i>Suitable for lighting works of art, paintings.</i>
	Adatto per installazione in Ospedale. <i>Suitable for installation in hospitals.</i>
	Adatto per installazione in Ipermercati, Supermercati. <i>Suitable for installation in hypermarkets, supermarkets.</i>
	Adatto per installazione in negozi in genere. <i>Suitable for installation in shops in general.</i>
	Adatto per installazione in parcheggi. <i>Suitable for installation in car parks.</i>
	Adatto per installazione all'aperto, terrazzi anche scoperti. <i>Suitable for installation outdoors, even open terraces.</i>
	Adatto per installazione in bagni. <i>Suitable for installation in bathrooms.</i>
	Adatto per installazione in zone umide. <i>Suitable for installation in wet areas.</i>

Colore corpo apparecchi - <i>Luminaire body color</i>	
	Bianco - <i>White</i>
	Nero - <i>Black</i>
	Grigio - <i>Grey</i>
	Argento sabbato - <i>Sanded silver</i>
	Argento - <i>Silver</i>
	Alluminio lucido - <i>Polished aluminum</i>
	Trasparente - <i>Transparent</i>
	Cromo - <i>Chrome</i>
	Oro - <i>Gold</i>
	Argento lucido - <i>Polished Silver</i>
	Trasparente - <i>Transparent</i>
	Specchio - <i>Mirror</i>
	Vetro satinato - <i>Frosted glass</i>
	Vetro fumè - <i>Fumè glass</i>
	Rame - <i>Copper</i>

## Apparecchi in emergenza - *Emergency wired luminaires*

### Apparecchi di illuminazione cablati in emergenza

Relco nella politica di offrire un servizio migliore alla clientela, ha deciso di utilizzare nei suoi apparecchi di illuminazione dotati di emergenza, solo INVERTER PER EMERGENZA CON AUTOTEST.

Le norme europee EN 1838, EN 60598-2-22, relative ai sistemi di illuminazione di emergenza, impongono che periodicamente, siano effettuati dei test per verificare sia il funzionamento sia l'efficienza (durata in emergenza) degli apparecchi di illuminazione che svolgono anche la funzione di illuminazione di emergenza. Questo costringe i manutentori dell'impianto ad interrompere la linea di alimentazione ed effettuare test con cadenza settimanale (test funzionale), e con cadenza trimestrale o annuale (test di autonomia).

Con i nostri kit di emergenza con autotest (conformi alla normativa europea EN 62034) queste prove vengono svolte automaticamente con cadenza programmabile in fase di installazione. Inoltre il nostro inverter analizza i tempi di normale accensione e spegnimento dell'apparecchio ed effettua (qualora possibile) i test nelle ore di assenza delle persone.

Eventuali anomalie sono segnalate tramite un indicatore (led) rosso verde.

A partire dal colore della segnalazione è possibile stabilire in maniera univoca gli eventuali problemi di funzionamento come evidenziato nella tabella seguente.

### Emergency wired luminaires

Relco in its policy of offering a better service to customers, has decided to use only EMERGENCY INVERTER WITH SELF-TEST in its luminaires equipped with emergency.





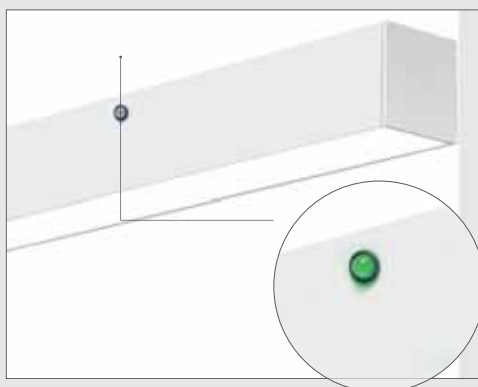

The European standards EN 1838, EN 60598-2-22, relating to emergency lighting systems, require that tests be periodically carried out to verify both the functioning and the efficiency (duration in emergency) of the lighting fixtures which also the emergency lighting function. This forces the system maintainers to interrupt the power supply line and carry out tests on a weekly basis (functional test), and on a quarterly or annual basis (autonomy test).

With our emergency kits with self-test (complying with European standard EN 62034) these tests are carried out automatically with a programmable cadence during installation.

Furthermore, our inverter analyzes the normal switching on and off times of the appliance and carries out (where possible) the tests in the hours when people are absent.

Any anomalies are signaled by a red-green indicator (led). Starting from the color of the signal, it is possible to unequivocally establish any functioning problems as shown in the following table.



Colore LED - <i>LED indication</i>	Stato - <i>Status</i>	
	Verde fisso - <i>Permanent Green</i>	Batteria carica o in carica - <i>Battery charge or charging</i>
	Verde lampeggiante - <i>Flashing Green</i>	Funzione TEST avviata - <i>TEST in progress</i>
	Verde lampeggiante lento (1s ON - 1s OFF) Slow flashing green (1s ON - 1s OFF)	TEST di autonomia avviato Autonomy TEST in progress
	Rosso fisso - <i>Permanent Red</i>	Lampada guasta - <i>Lamp failure</i>
	Rosso lampeggio veloce (0,1s ON - 0,1s OFF) Fast flashing Red (0,1s ON - 0,1s OFF)	Guasto circuito di ricarica - <i>Charging failure</i>
	Lampeggio Rosso lento (1s ON - 1s OFF) Slow flashing Red (1s ON - 1s OFF)	Batteria guasta - <i>Battery failure</i>
	Verde e Rosso OFF - <i>Green and Red OFF</i>	Emergenza ON - <i>Emergency ON</i>

# LED Micro Pinguino - LED Pinguino - LED Puma - LED Maxi Puma

La certificazione fotometrica dei nostri apparecchi viene sempre effettuata da un istituto esterno. Efficienza luminosa e "lm Output" sono quindi il risultato di tale istituto.

*The photometric certification of our appliances is always carried out by an external institute. Luminous efficiency and "lm Output" are therefore the result of this institute.*

Gamma completa di proiettori ideale per illuminare parcheggi, piazzali, facciate, zone carico-scarico e grandi aree in generale.

**Installazione:** su superfici verticali e orizzontali.

**Corpo e telaio:** in alluminio pressofuso UNI EN 1706 verniciato con polvere termoindurente poliestere.

**Staffa di fissaggio:** in acciaio, verniciata con polvere termoindurente poliestere, con goniometro graduato per un corretto puntamento del fascio luminoso.

**Verniciatura:** di tipo poliestere eseguita a polvere, resistente agli agenti atmosferici, alla corrosione. Grigio RAL 9007.

**Ottica:** concentrante, semi concentrante, diffondente e asimmetrica.

**Schermo:** vetro temprato di spessore 4mm resistente agli shock termici e agli urti.

**Sorgente:** LED LUMILEDS

**Temperatura di colore:** 4000K; altre temperature di colore a richiesta (2200K - 2700K - 3000K - 5000K - Consegna 60 giorni).

**Protezione alle sovratensioni inclusa:**

Modo differenziale 6kV (L-N)

Modo comune 8kV (L-GND, N-GND, L&N-GND)

**A richiesta:** versione con protezione maggiorata (10kV) contro gli impulsi aggiungendo il cod. RO0640/N.

Mantenimento del flusso luminoso minimo al 80% - 80.000h (L80B20).

**Driver:** incorporato   
Fattore di potenza  $\geq 0,95$ .

**Norme di riferimento:** IEC 61000-4-5; EN60598-1; EN60598-2-1; EN62471; EN62031; EN60598-2-5; EN61547

*Complete range projectors perfect to light up car parks, squares, facades, loading and unloading areas and large areas in general.*

*Installation: on vertical and horizontal surfaces.*

*Housing and frame: made by UNI EN 1706 die-cast aluminum, coated with polyester thermoset powder.*

*Fixing bracket: made by stainless steel, coated with polyester thermoset powder, with graduated goniometer to allow the correct orientation of light beam*

*Coating: coated with powdered polyester, resistant to atmospheric agents and corrosion. RAL 9007 Grey.*

*Optic: clumping, semi-clumping, diffused and asymmetric*

*Shield: tempered glass with 4mm thickness resistant to thermal shocks and collisions.*

*Light source: LED LUMILEDS*

*Color temperature: 4000K; other color temperatures available on demand (2200K - 2700K - 3000K - 5000K. Delivery time: 60 days)*

*Protection against overvoltages included:*

*Differential mode 6kV (L-N)*

*Standard mode 8kV (L - GND, N-GND, L&N-GND).*

*Maintenance of minimum luminous flux to 80% - 80.000h (L80B20).*

*Driver: included   
Power factor  $\geq 0,95$*

*Standard reference: IEC 61000-4-5; EN60598-1; EN60598-2-1; EN62471; EN62031; EN60598-2-5; EN61547*



# LED Micro Pinguino - LED Pinguino - LED Puma - LED Maxi Puma



LED Maxi Puma - LED Maxi Puma ASY

LED Puma - LED Puma ASY

LED Pinguino - LED Pinguino ASY

LED Micro Pinguino



A richiesta - On demand



Vedi Pag. VI - See page VI

Floodlight

220-240 Vac	110 Vac On demand	50/60 Hz	IP66	IK09	CRI > 80	+40 C -20	850°		CE		
	TECEE		RG0	LOW FLICKER	Driver included MULTIPOWER RIPPLE FREE						

## LED Micro Pinguino

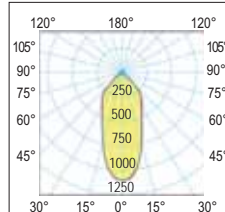
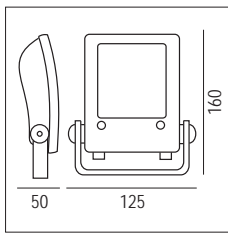

40°  
Intermedio - Medium



colour	W	angle	K	nominal lm tc = 25°C	lm output	lm/W	pcs	Kg	CELL
B	15	40°	3000	2100	1400	90	8	0,50	28211/LED
B	15	40°	4000	2100	1400	90	8	0,50	28212/LED
G	15	40°	3000	2100	1400	90	8	0,50	28213/LED
G	15	40°	4000	2100	1400	90	8	0,50	28214/LED
N	15	40°	3000	2100	1400	90	8	0,50	28215/LED
N	15	40°	4000	2100	1400	90	8	0,50	28216/LED

A richiesta: ottica 25° - On demand: optic 25°

## LED Pinguino

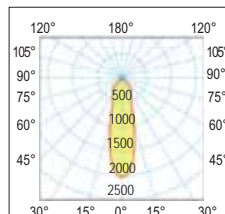
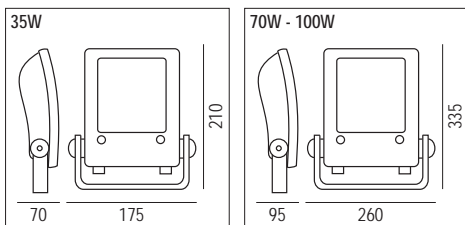

25°  
Semi-concentrate - Spot

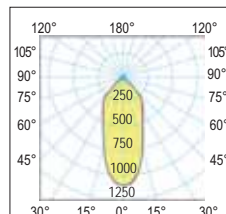

40°  
Intermedio - Medium

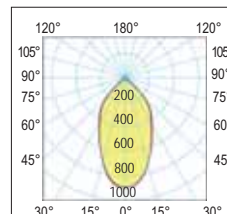

60°  
Semi-diffondente - Flood

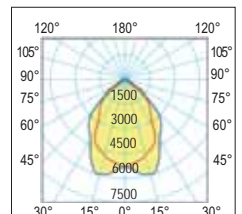

90°  
Diffondente - Wide

colour	W	angle	K	nominal lm tc = 25°C	lm output	lm/W	pcs	Kg	CELL
G	35	25°	4000	5870	4514	132	4	3,20	28203/LED/25
G	70	25°	4000	8470	7700	110	4	3,20	28208LED25S
G	35	40°	4000	5870	4514	132	4	3,20	28203/LED/40
G	70	40°	4000	8470	7700	110	4	3,20	28208LED40S
G	35	60°	3000	5870	4514	132	4	3,20	28203/L/60-3K
G	35	60°	4000	5870	4514	132	4	3,20	28203/LED/60
G	35	60°	4000	5870	4514	132	4	3,20	28203/LED60DA
G	70	60°	4000	8470	7700	110	4	3,20	28208LED60S
G	100	90°	3000	12100	11000	110	4	3,50	28209/L/S-3K
G	100	90°	4000	12100	11000	110	4	3,50	28209/LED/S

DALI 2



# LED Pinguino Eye - Luce solo all'occorrenza - Light only when needed

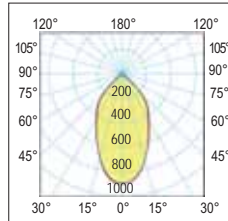

60°  
Semi-diffondente - Flood

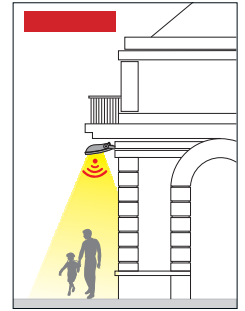
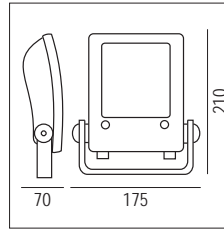

colour	W	angle	K	nominal lm tc = 25°C	lm output	lm/W	pcs	Kg	CELL
G	15	60°	4000	2200	1800	120	4	0,50	28203/LED/EYE
G	30	60°	3000	4400	3600	120	4	0,50	28205/LED/EYE
G	30	60°	4000	4400	3600	120	4	0,50	28206/LED/EYE

A richiesta: per quantità minima 100 pezzi disponibili a 2700K - On demand: for quantity min 100 pcs available 2700K

# LED Pinguino ASY

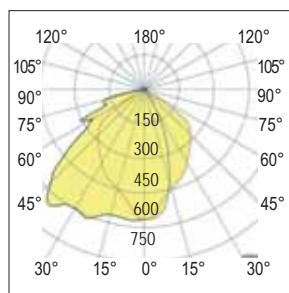
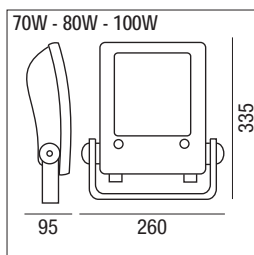
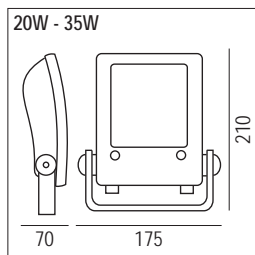

ASY  
Asimmetrico - Asymmetric

	colour	W	angle	K	nominal lm tc = 25°C	lm output	lm/W	pcs	Kg	CELL
	G	20	ASY	3000	3400	3000	150	4	3,20	20ASY-3K
	G	20	ASY	4000	3400	3000	150	4	3,20	20ASY-4K
DYNA	G	20	ASY	3000	3400	3000	150	4	3,20	35ASYDYNA5-3K
DYNA	G	20	ASY	4000	3400	3000	150	4	3,20	35ASYDYNA5-4K
	G	35	ASY	3000	5.000	4.400	125	4	3,20	28203/L/AS-3K
	G	35	ASY	4000	5.000	4.400	125	4	3,20	28203/LED/AS
DYNA	G	35	ASY	3000	5.000	4.400	125	4	3,20	50ASYDYNA5-3K
DYNA	G	35	ASY	4000	5.000	4.400	125	4	3,20	50ASYDYNA5-4K
	G	70	ASY	3000	10.000	8.750	125	4	3,20	28208LEDAS3KS
	G	70	ASY	4000	10.000	8.750	125	4	3,20	28208LEDASS
DYNA	G	70	ASY	3000	10.000	8.750	125	4	3,20	75ASYDYNA5-3K
DYNA	G	70	ASY	4000	10.000	8.750	125	4	3,20	75ASYDYNA5-4K
DYNA	G	80	ASY	3000	11.500	10.000	125	4	3,20	100ASYDYNA53K
DYNA	G	80	ASY	4000	11.500	10.000	125	4	3,20	100ASYDYNA54K
	G	100	ASY	3000	14.300	12.500	125	4	3,20	28209/L/AS-3K
	G	100	ASY	4000	14.300	12.500	125	4	3,20	28209/LED/AS



# LED Puma ASY

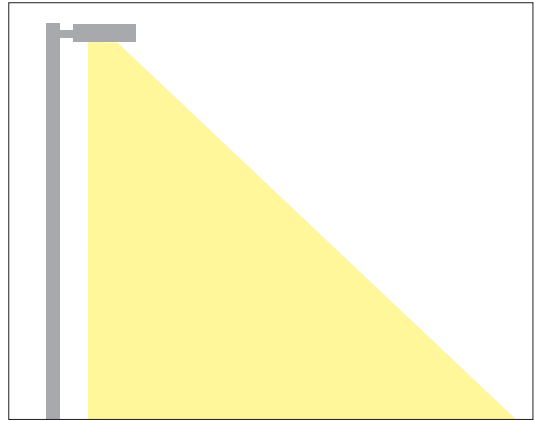
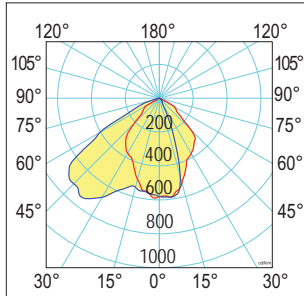

**ASY**  
Asimmetrico - *Asymmetric*

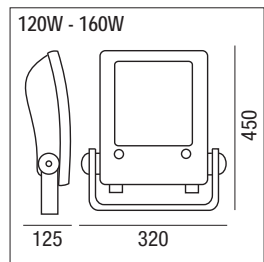

colour	W	angle	K	nominal lm tc = 25°C	lm output	lm/W	pcs	Kg	CELL	
<b>G</b>	120	ASY	3000	19.300	16800	140	2	5,80	28234LEDAS3KS	
<b>G</b>	120	ASY	4000	19.300	16800	140	2	5,80	28234LEDASS	
<b>DYNA</b>	<b>G</b>	120	ASY	3000	19.300	16800	140	2	5,80	28234ASDNA53K
<b>DYNA</b>	<b>G</b>	120	ASY	4000	19.300	16800	140	2	5,80	28234ASDNA54K
<b>G</b>	160	ASY	3000	25.700	22400	140	2	6,20	28259LEDAS3K	
<b>G</b>	160	ASY	4000	25.700	22400	140	2	6,20	28259LEDAS	
<b>DYNA</b>	<b>G</b>	160	ASY	3000	25.700	22400	140	2	6,20	28259ASDNA53K
<b>DYNA</b>	<b>G</b>	160	ASY	4000	25.700	22400	140	2	6,20	28259ASDNA54K

Floodlight

# LED Puma

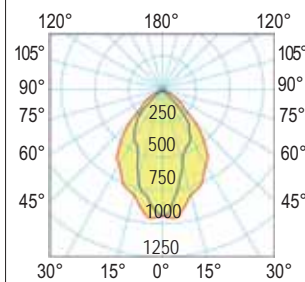

**40°/80°**  
Ovale diffondente - *Oval flood*

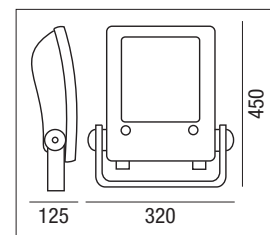

**DALI 2**

colour	W	angle	K	nominal lm tc = 25°C	lm output	lm/W	pcs	Kg	CELL	
<b>G</b>	120	40/80°	3000	19.300	16.800	140	2	5,80	28234LED803KS	
<b>G</b>	120	40/80°	4000	19.300	16.800	140	2	5,80	28234LED80S	
<b>DALI 2</b>	<b>G</b>	120	40/80°	4000	19.300	16.800	140	2	5,80	28234LED80DA
<b>G</b>	160	40/80°	3000	25.700	22.400	140	2	6,20	28259LED803K	
<b>G</b>	160	40/80°	4000	25.700	22.400	140	2	6,20	28259LED80	
<b>DALI 2</b>	<b>G</b>	160	40/80°	4000	25.700	22.400	140	2	6,20	28259LED80DA



Auf Anfrage kann LED Puma auch in einer Notfallversion geliefert werden - + Euro 200,00 vom Listenpreis (add /E nach dem code)  
Sur demande, LED Puma peut également être fourni en version de urgence - + Euro 200,00 à partir du prix tarif (ajouter / E après le code)



# LED Maxi Puma ASY

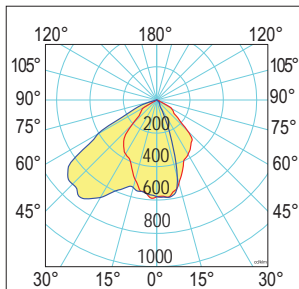

**ASY**  
Asimmetrico - *Asymmetric*

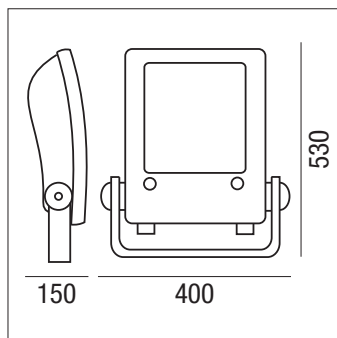

colour	W	angle	K	nominal lm tc = 25°C	lm output	lm/W	pcs	Kg	CELL
G	220	ASY	3000	35.400	30.800	140	2	10,00	28235LEDAS3K
G	220	ASY	4000	35.400	30.800	140	2	10,00	28235LEDAS
1-10Vdc	G	220	ASY	3000	35.400	30.800	2	10,00	28235LEDAS3KS
1-10Vdc	G	220	ASY	4000	35.400	30.800	2	10,00	28235LEDASS
DALI 2	G	220	ASY	3000	35.400	30.800	2	10,00	28235LEDAS3KD
DALI 2	G	220	ASY	4000	35.400	30.800	2	10,00	28235LEDASD



A richiesta LED Puma può essere fornito anche in versione emergenza - + Euro 200,00 da prezzo di listino (aggiungere /E dopo il codice)  
On request, LED Puma can also be supplied in an emergency version - + Euro 200.00 from the list price (add / E after the code)

# LED Maxi Puma

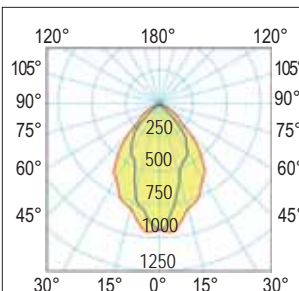

**40°/80°**  
Ovale diffondente - *Oval flood*

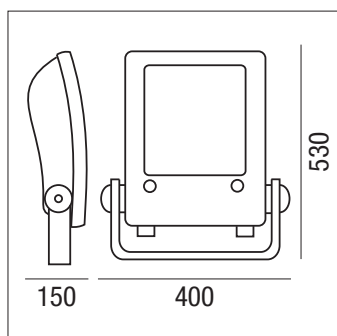

colour	W	angle	K	nominal lm tc = 25°C	lm output	lm/W	pcs	Kg	CELL
G	220	40/80°	3000	35.400	30.800	140	2	10,00	28235LED803K
G	220	40/80°	4000	35.400	30.800	140	2	10,00	28235LED80
1-10Vdc	G	220	40/80°	3000	35.400	30.800	2	10,00	28235LED803KS
1-10Vdc	G	220	40/80°	4000	35.400	30.800	2	10,00	28235LED80S
DALI 2	G	220	40/80°	3000	35.400	30.800	2	10,00	28235LED803KD
DALI 2	G	220	40/80°	4000	35.400	30.800	2	10,00	28235LED80D



A richiesta LED Puma può essere fornito anche in versione emergenza - + Euro 200,00 da prezzo di listino (aggiungere /E dopo il codice)  
On request, LED Puma can also be supplied in an emergency version - + Euro 200.00 from the list price (add / E after the code)

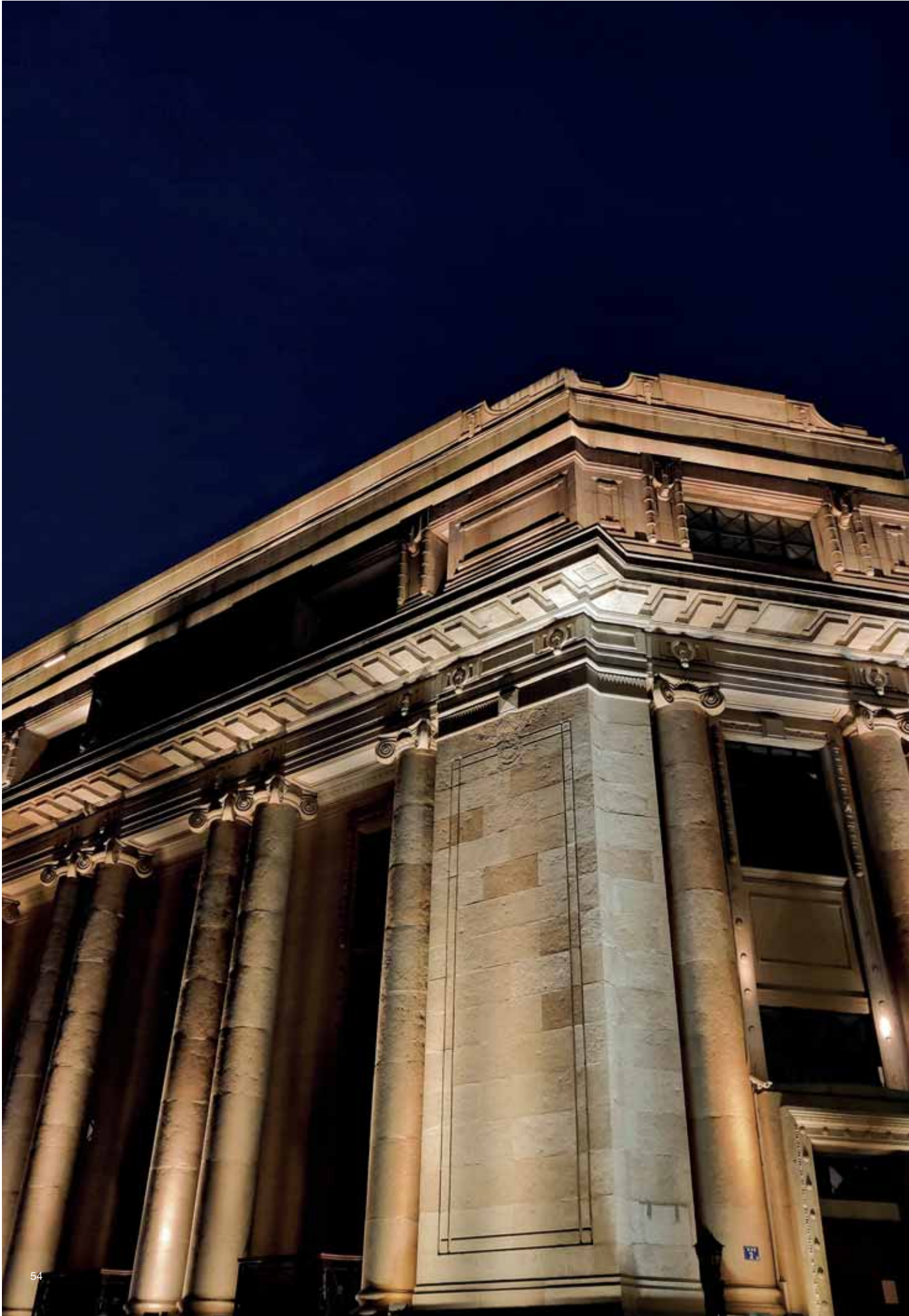



# LED Pinguino - LED Puma

## Dettagli - Details



Staffa di fissaggio ruotabile con goniometro. Doppia vite blocca-staffa per resistenza al vento.  
*Rotating support with goniometer and double bracket blocking screws against the wind.*

Alette di raffreddamento maggiorate, pressacavo IP66.  
*Cooling grilles, IP66 cable gland.*



Dispositivo anticondensa: valvola di compensazione e riciclo dell'aria.

Anti-condensate device: valve for compensation and circulation of air.



Tutti i modelli LED Pinguino e LED Puma sono completi di connettore IP68 per una rapida installazione

All LED Pinguino and LED Puma models are complete with IP68 connector for quick installation

## Soluzioni NON incluse per aumentare il risparmio energetico NOT included solutions to increase energy saving

Fig. 1 - Esempio applicativo 2 steps - Application example 2 steps

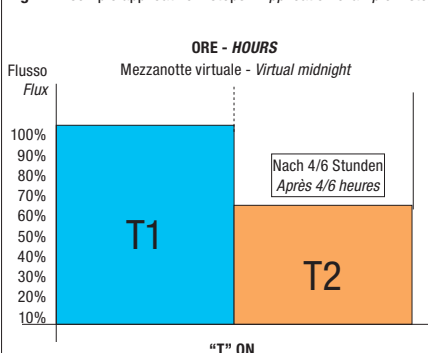

T1 = 100% Flusso luminoso  
T1 = 100% Luminous flux  
T2 = 70% Flusso luminoso  
T2 = 70% Luminous flux

Minimo tempo di accensione per funzionamento automatico 4 ore (3 giorni).

Accensioni da 1 a 4 ore oppure superiori alle 23 ore resettano il sistema.

The minimum ignition time for automatic operation is 4 hours (three days).

Ignitions 1 hour ignored. Switching from 1 to 4 hours or higher with 23 hours reset the system.

**DYNA CONTROL** è un sistema di controllo del flusso luminoso delle lampade che si basa sul calcolo della mezzanotte virtuale. Il sistema entra in funzione alla prima accensione calcolando per 3 giorni i tempi di accensione. Il quarto giorno il sistema, in modo autonomo, calcola la mezzanotte virtuale eseguendo una regolazione del flusso e regolando la lampada come indicato sullo schema di Fig. 1. La riduzione del flusso luminoso avviene senza la necessità di alcun cavo di connessione aggiuntivo o dispositivo di comando esterno, questo sistema consente di ottenere un notevole risparmio energetico. N.B. su richiesta è possibile eseguire la modifica delle impostazioni di fabbrica della mezzanotte virtuale adattandole alle specifiche del cliente.

**DYNA CONTROL** is a control system for the luminous flux of the lamps which is based on virtual midnight calculation. The system starts running when turned on for the first time, calculating the start-up times for 3 days. On the fourth day, the system automatically calculates the virtual midnight by performing a flux adjustment and adjusting the lamp as indicated on the diagram of Fig. 1. The reduction of the luminous flux occurs without the need for any additional connection cable or external control device. This system can achieve considerable energy saving. N.B. the factory settings of the virtual midnight can be modified on request, adjusting them to the customer's specifications.

## Accessori non inclusi - Not included accessories



Code: RO0640/N

Dispositivo di protezione conforme alla Norma EN 61547 contro i fenomeni impulsivi atto a proteggere il modulo LED e il relativo alimentatore: classe II fino a 10kV

Protection device in compliance with the EN 61547 standard to counteract the impulsive phenomena designed to protect the LED module and the relative power supply: class II protection up to 10kV

### Sovratensioni

Le sovratensioni sono un rapido innalzamento della differenza di potenziale tra le diverse polarità (Fase o Neutro) e la Terra, in alcuni casi sono talmente elevate da superare la soglia di isolamento dei componenti elettronici causandone così il danneggiamento. Esistono anche casi di sovratensioni di entità inferiore, le quali non provocano un immediato guasto dei moduli LED o driver privi di protezione, ma se nel tempo si verificano ripetutamente possono provocare il deterioramento dei LED, di conseguenza, una durata ridotta. Nel caso di sovratensioni di elevata entità, come la caduta dei fulmini, provocano invece un guasto immediato dei moduli LED o dei driver. Le sovratensioni, di fatto, provocano degli impulsi di energia con correnti elevate sia nel driver che nei moduli LED.

### Overvoltages

Overvoltages are a rapid rise in the potential difference between the different polarities (Phase or Neutral) and the Earth, in some cases they are so high as to exceed the isolation threshold of the electronic components, thus causing damage. There are also cases of minor overvoltages, which do not cause an immediate failure of the unprotected LED modules or drivers, but if they occur repeatedly over time they can cause deterioration of the LEDs, consequently a reduced life span. In the event of high voltage surges, such as lightning strikes, they cause immediate failure of the LED modules or drivers. The overvoltages, in fact, cause energy pulses with high currents in both the driver and the LED modules.

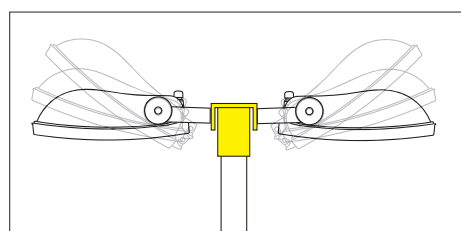

Code: 703952.NEW

Attacco palo per 1 o 2 proiettori, Ø 60/76 mm in ferro verniciato con polveri termoindurenti poliesteri resistenti alla corrosione ed agli agenti atmosferici.

Pole attachment for either 1 or 2 floodlights, size Ø60/76mm made by iron coated with polyester thermosetting powder, offering high resistance to rust and external atmospheric agents

# LED Tigre - LED Tigre ASY



Gamma completa di proiettori da esterno ideale per illuminare parcheggi, piazzali, facciate, zone carico-scarico e grandi aree in generale.

**Installazione:** a palo o a parete.

**Corpo e telaio:** in alluminio pressofuso UNI EN 1706 verniciato con polvere termoindurente poliestere.

**Staffa di fissaggio:** in acciaio, verniciata con polvere termoindurente poliestere, con goniometro graduato per un corretto puntamento del fascio luminoso.

**Verniciatura:** di tipo poliestere eseguita a polvere, resistente agli agenti atmosferici, alla corrosione. Grigio RAL 9007.

**Ottica:** semi concentrante, intermedia, semi-diffondente e asimmetrica.

**Schermo:** vetro temprato trasparente di spessore 4mm resistente agli shock termici e agli urti.

**Sorgente:** LED LUMILEDS

Mantenimento del flusso luminoso minimo al 80% - 80.000h (L80B20).

**Temperatura di colore:** 4000K; altre temperature di colore a richiesta (2200K - 2700K - 3000K - 5000K Consegna 60 giorni).

**Driver:** incorporato .  
Fattore di potenza  $\geq 0,95$ .

**Protezione alle sovratensioni inclusa:**

Modo differenziale 6kV (L-N)

Modo comune 8kV (L-GND, N-GND, L&N-GND)

**A richiesta:** versione con protezione maggiorata (10kV) contro gli impulsi aggiungendo il cod. RO0640/N.

**Norme di riferimento:** IEC 61000-4-5; EN60598-1; EN60598-2-1; EN62471; EN62031; EN60598-2-5; EN61547

*Complete range of outdoor projectors perfect to light up car parks, squares, facades, loading and unloading areas and large areas in general.*

*Installation: on pole or wall*

*Housing and frame: made by UNI EN 1706 die-cast aluminum, coated with polyester thermoset powder.*

*Fixing bracket: made by stainless steel, coated with polyester thermoset powder, with graduated goniometer to allow the correct orientation of light beam*

*Coating: coated with powdered polyester, resistant to atmospheric agents and corrosion. RAL9007 Grey.*

*Optic: spot, medium, flood and asymmetric.*

*Shield: transparente tempered glass with 4mm thickness resistant to thermal shocks and collisions*

*Light source: LED LUMILEDS*

*Maintenance of minimum luminous flux to 80% - 80.000h (L80B20).*

*Color temperature: 4000K; other color temperatures available on demand (2200K - 2700K - 3000K - 5000K. Delivery time: 60 days)*

*Driver: included .*

*Power factor  $\geq 0,95$*

*Protection against overvoltages included:*

*Differential mode 6kV (L-N)*

*Standard mode 8kV (L - GND, N-GND, L&N-GND).*

*Standard reference: IEC 61000-4-5; EN60598-1; EN60598-2-1; EN62471; EN62031; EN60598-2-5; EN61547*

La certificazione fotometrica dei nostri apparecchi viene sempre effettuata da un istituto esterno. Efficienza luminosa e "lm Output" sono quindi il risultato di tale istituto.

*The photometric certification of our appliances is always carried out by an external institute. Luminous efficiency and "lm Output" are therefore the result of this institute.*

A richiesta - On demand

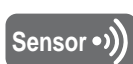

Vedi Pag. VI - See page VI



220-240 Vac	110 Vac On demand	50/60 Hz	IP66	IK09	CRI > 80	+40°C -20°C	850°		CE		
		RG0	LOW FLICKER	Driver included MULTIPOWER RIPPLE FREE							

## LED Tigre

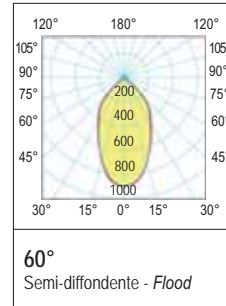
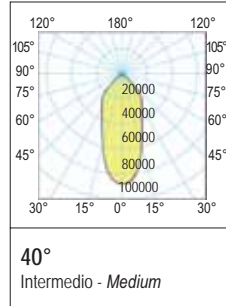
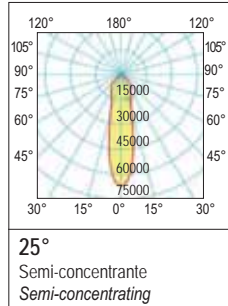
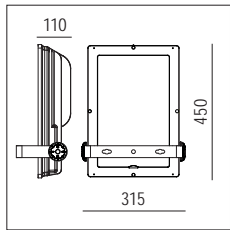

	colour	W	angle	K	nominal lm tc = 25°C	lm output	lm/W	pcs	Kg	CELL
1-10Vdc	G	160	25°	3000	25.700	22.400	140	1	7,50	28700/L/253KS
1-10Vdc	G	160	25°	4000	25.700	22.400	140	1	7,50	28700/LED/25S
1-10Vdc	G	160	40°	3000	25.700	22.400	140	1	7,50	28700/L/403KS
1-10Vdc	G	160	40°	4000	25.700	22.400	140	1	7,50	28700/LED/40S
1-10Vdc	G	160	60°	3000	25.700	22.400	140	1	7,50	28700/L/603KS
1-10Vdc	G	160	60°	4000	25.700	22.400	140	1	7,50	28700/LED/60S
1-10Vdc	G	220	25°	4000	35.400	30.800	140	1	7,50	28701/LED/25S
DALI 2	G	220	25°	4000	35.400	30.800	140	1	7,50	28701/L/25/DA
G	200	40°	4000	31.600	28.000	140	1	7,50	28701/TV/40	
DALI 2	G	200	40°	4000	31.600	28.000	140	1	7,50	28701/TV/40D
1-10Vdc	G	220	40°	4000	35.400	30.800	140	1	7,50	28701/LED/40S
G	220	40°	4000	35.400	30.800	140	1	7,50	28701/LED/40	
G	200	60°	4000	31.600	28.000	140	1	7,50	28701/TV/60	
DALI 2	G	200	60°	4000	31.600	28.000	140	1	7,50	28701/TV/60D
1-10Vdc	G	220	60°	4000	35.400	30.800	140	1	7,50	28701/LED/60S
DALI 2	G	220	60°	4000	35.400	30.800	140	1	7,50	28701/L/60/DA

TV = Senza cornice (tutto vetro) - Without frame (all glass)

## LED Tigre ASY

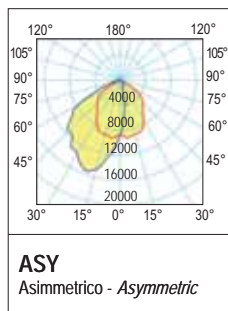
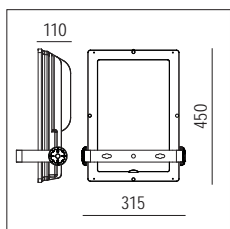

	colour	W	angle	K	nominal lm tc = 25°C	lm output	lm/W	pcs	Kg	CELL
1-10Vdc	G	160	ASY	3000	25.700	22.400	140	1	7,50	28700/L/AS3KS
1-10Vdc	G	160	ASY	4000	25.700	22.400	140	1	7,50	28700/LED/ASS
DALI 2	G	160	ASY	4000	25.700	22.400	140	1	7,50	28700/L/AS/DA
G	200	ASY	4000	31.600	28.000	140	1	7,50	28701/TV/ASY	
DALI 2	G	200	ASY	4000	31.600	28.000	140	1	7,50	28701/TV/ASDA
1-10Vdc	G	220	ASY	4000	35.400	30.800	140	1	7,50	28701/LED/ASS
DALI 2	G	220	ASY	4000	35.400	30.800	140	1	7,50	28701/L/AS/DA

TV = Senza cornice (tutto vetro) - Without frame (all glass)

# LED Tigre SMD

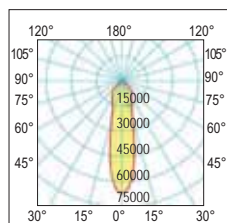
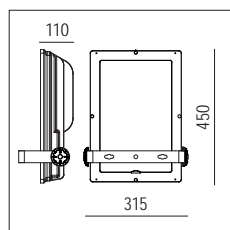

**25°**  
Semi-concentrate - *Spot*

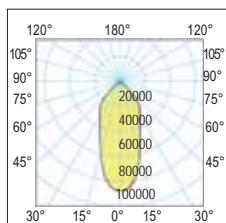

**40°**  
Intermedio - *Medium*

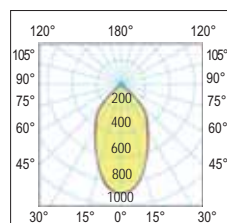

**60°**  
Semi-diffondente - *Flood*

	colour	W	angle	K	nominal lm tc = 25°C	lm output	lm/W	pcs	Kg	CELL
1-10Vdc	G	160	25°	3000	25.700	22.400	140	1	7,50	28700253KSSMD
1-10Vdc	G	160	25°	4000	25.700	22.400	140	1	7,50	2870025SSMD
1-10Vdc	G	160	40°	3000	25.700	22.400	140	1	7,50	28700403KSSMD
1-10Vdc	G	160	40°	4000	25.700	22.400	140	1	7,50	2870040SSMD
1-10Vdc	G	160	60°	3000	25.700	22.400	140	1	7,50	28700603KSSMD
1-10Vdc	G	160	60°	4000	25.700	22.400	140	1	7,50	2870060SSMD
	G	200	40°	4000	31.600	28.000	140	1	7,50	2870140SMD
DALI 2	G	200	40°	4000	31.600	28.000	140	1	7,50	2870140DSMD
	G	200	60°	4000	31.600	28.000	140	1	7,50	2870160SMD
DALI 2	G	200	60°	4000	31.600	28.000	140	1	7,50	2870160DSMD

Floodlight

# LED Tigre SMD ASY - Ideale per campi di PADEL - Ideal for PADEL fields

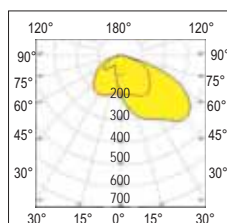
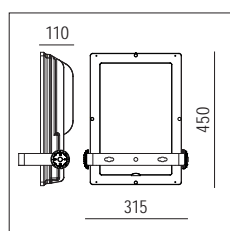

**ASY**  
Asimmetrico - *Asymmetric*



	colour	W	angle	K	nominal lm tc = 25°C	lm output	lm/W	pcs	Kg	CELL
1-10Vdc	G	160	ASY	3000	25.700	22.400	140	1	7,50	28700AS3KSSMD
1-10Vdc	G	160	ASY	4000	25.700	22.400	140	1	7,50	28700ASSMD
DALI 2	G	160	ASY	4000	25.700	22.400	140	1	7,50	28700AS/DASMD
	G	200	ASY	4000	31.600	28.000	140	1	7,50	28701ASYSM
DALI 2	G	200	ASY	4000	31.600	28.000	140	1	7,50	28701ASDASMD



# LED Tigre - LED Tigre ASY

## Dettagli - Details



Led Driver incorporati nel prodotto.

Protezione contro gli impulsi 8kV conforme alla Norma EN 61547.

Led Driver incorporated in the product.

8kV Impulse protection in accordance with EN 61547.



Dispositivo anticondensa: valvola di compensazione e riciclo dell'aria.

Anti-condensate device: valve for compensation and circulation of air.



Alette di raffreddamento maggiorate, pressacavo IP66.

Cooling grilles, IP66 cable gland.



Completo di connettore IP68 per una rapida installazione

Complete with IP68 connector for quick installation

## Accessori non inclusi - Not included accessories



**Code:** RO0640/N

Dispositivo di protezione conforme alla Norma EN 61547 contro i fenomeni impulsivi atto a proteggere il modulo LED e il relativo alimentatore: classe II (a richiesta protezione fino a 10kV)

Protection device in compliance with the EN 61547 standard to counteract the impulsive phenomena designed to protect the LED module and the relative power supply: class II (protection up to 10kV available on request)



**Code:** 11111

Staffa 2x per l'applicazione di due apparecchi - Bracket for the application of two lighting fixtures



**A richiesta:** verniciatura resistente a 2.000 ore di esposizione alla nebbia salina in accordo alla norma ISO 9227 certificato da Ente esterno.

On request: painting resistant to 2,000 hours of exposure to salt spray in accordance with ISO 9227 certified by an external body.



**Cod.** 703952.NEW

Attacco palo per 1 o 2 proiettori, Ø60/76 mm. In ferro verniciato con polveri termoindurenti poliesteri resistenti alla corrosione ed agli agenti atmosferici.

Pole attachment for either 1 or 2 floodlights, size Ø 60/76mm. Iron coated with polyester thermosetting powder coating, offering high resistance to rust and external atmospheric agents.



Predisposto Zhaga Socket per sistemi wireless  
Prepared for Zhaga Socket for wireless systems

# BASIC series LED Virgola



Gamma di proiettori da esterno in alluminio pressofuso ideale per illuminare aree verdi, giardini, parcheggi, piazzali, facciate, zone di carico-scarico e grandi aree in generale.

Installazione: su superfici verticali e orizzontali (completo di staffa di fissaggio) con corpo e telaio in alluminio pressofuso UNI 5076 di tipo poliestere eseguita a polvere, resistente agli agenti atmosferici, alla corrosione e staffa di fissaggio in acciaio, verniciata con polvere termoisolante poliestere.

**Colore:** nero RAL 9004.

**Optica:** diffusore 120°

**Schermo:** vetro temprato di spessore 4mm resistente agli shock termici e agli urti.

**Sorgente LED SMD:** incorporato con temperatura di colore 4000K; altre temperature di colore a richiesta.

**Driver:** incorporato fattore di potenza:  $\geq 0,9$

Range of outdoor projectors made by die-cast aluminum perfect to light up parks, gardens, car parks, squares, facades, loading and unloading areas and large areas in general.

Installation: on vertical and horizontal surfaces (complete with fixing bracket), with housing and frame made by UNI 5076 die-cast aluminum, coated with powdered polyester, resistant to atmospheric agents and corrosion and fixing bracket made by stainless steel, coated with polyester thermoset powder.

**Color:** RAL 9004 black color.

**Optic:** 120° diffused

**Shield:** tempered glass with 4mm thickness resistant to thermal shocks and collisions

**Light source SMD LED:** included with color temperature 4000K; other color temperatures available on demand.

**Driver:** included Power factor:  $\geq 0,9$

50/60 Hz	100-264 Vac	IP65	IK08	CRI > 80	+40 C° -20	850°		CE			

Floodlight



LED Virgola 50W

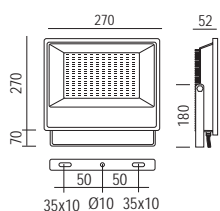

LED Virgola 100W

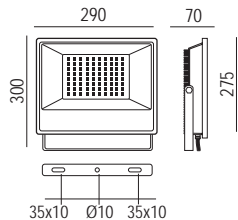

LED Virgola 150W

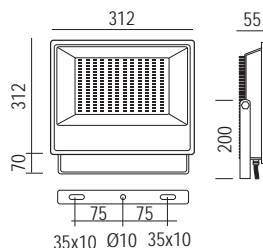

LED Virgola 200W

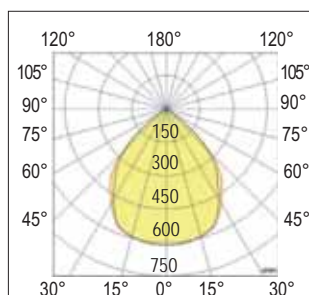
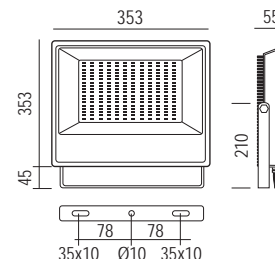

Diffondente - Flood

colour	W	angle	K	lm output	lm/W	pcs	Kg	CELL
N	50	120°	4000	5.500	110	1	1,00	27303/NEW
N	100	120°	4000	11.000	110	1	2,10	RL2180362
N	150	120°	4000	16.500	110	1	3,20	RL2180372
N	200	120°	4000	22.000	110	1	3,60	RL2180382



# BASIC series LED Virgola

**3 CCT** ( 3000 / 4000 / 6000K )  
**4 Power** ( 100 / 120 / 150 / 200W )



**Colore:** nero RAL 9004.

**Ottica:** diffondente 120°

**Schermo:** vetro temprato di spessore 4mm resistente agli shock termici e agli urti.

**Driver:** incorporato fattore di potenza: ≥0,9

**Color:** RAL 9004 black color.

**Optic:** 120° diffused

**Shield:** tempered glass with 4mm thickness resistant to thermal shocks and collisions

**Driver:** included Power factor: ≥0,9

Possibilità di scelta della temperatura colore e della potenza

With the possibility of choosing the color temperature and power

50/60 Hz	100-264 Vac	IP65	IK08	CRI > 80	+40 C° -20	850°		CE			



Pressacavo IP65  
Waterproof connector IP65



Dissipatore in alluminio pressofuso per un'ottima dissipazione del calore.  
Die casting aluminum, excellent heat dispersion.

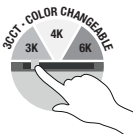
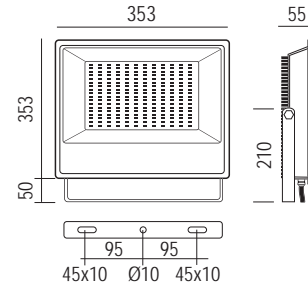

Dip switch per la selezione della temperatura colore  
Dip switch for color Kelvin temperature

<b>6000K</b> Bianco freddo Cool white	<b>4000K</b> Bianco neutro Neutral white	<b>3000K</b> Bianco caldo Warm white

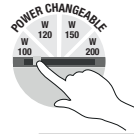

Dip switch per la selezione della potenza scelta  
Dip switch for the power choice

<b>100W</b>	<b>120W</b>	<b>150W</b>	<b>200W</b>

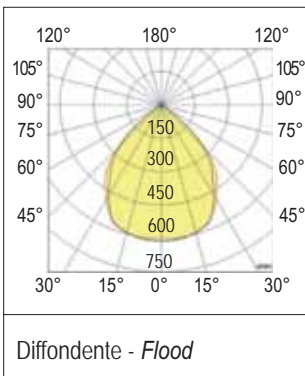

colour	W	angle	K	lm output	lm/W	pcs	Kg	CELL
N	100	120°	3000 / 4000 / 6000	12.000	120	1	1,00	RL21807X1
	120			14.400				
	150			18.000				
	200			24.000				

Taratura di fabbrica - Factory setting

Floodlight

# LED Jaguaro

Gamma completa di proiettori da esterno ideale per illuminare parcheggi, piazzali, facciate, zone carico-scarico e grandi aree in generale.

**Installazione:** a palo o a parete.

**Corpo e telaio:** in alluminio pressofuso UNI EN 1706 verniciato con polvere termoindurente poliestere.

**Staffa di fissaggio:** in acciaio, verniciata con polvere termoindurente poliestere, con goniometro graduato per un corretto puntamento del fascio luminoso.

**Verniciatura:** di tipo poliestere eseguita a polvere, resistente agli agenti atmosferici, alla corrosione. Nero RAL 9005.

**Ottica:** semi concentrante, intermedia e semi-diffondente in PMMA con resistenza alle alte temperature, agli shock termici e agli urti

**Rischio fotobiologico:** IEC 62471 - rischio esente

**Schermo:** vetro temprato trasparente di spessore 4mm resistente agli shock termici e agli urti.

**Sorgente:** LED SMD 5050 LUMILEDS  
Mantenimento del flusso luminoso (L80-B20 > 50.000h).

**Temperatura di colore:** 4000K; altre temperature di colore a richiesta (2200K - 2700K - 3000K - 5000K  
Consegna 60 giorni).

**Driver:** incorporato   
Fattore di potenza  $\geq 0,95$ .

**Protezione alle sovratensioni inclusa:**

Modo differenziale 5kV (L-N)

Modo comune 10kV (L-GND, N-GND, L&N-GND)

Protezione: 5/10kV

**Norme di riferimento:** IEC 61000-4-5; EN60598-1; EN60598-2-1; EN62471; EN62031; EN60598-2-5; EN61547

*Complete range of outdoor projectors perfect to light up car parks, squares, facades, loading and unloading areas and large areas in general.*

*Installation: on pole or wall*

*Housing and frame: made by UNI EN 1706 die-cast aluminum, coated with polyester thermoset powder.*

*Fixing bracket: made by stainless steel, coated with polyester thermoset powder, with graduated goniometer to allow the correct orientation of light beam*

*Coating: coated with powdered polyester, resistant to atmospheric agents and corrosion. RAL 9005 Black.*

*Optic: spot, medium and flood.*

*Eyesafety: IEC 62471 - risk exempt*

*Shield: transparente tempered glass with 4mm thickness resistant to thermal shocks and collisions*

*Light source: LED SMD 5050 LUMILEDS*

*Maintenance of minimum luminous flux (L80-B20 > 50.000h).*

*Color temperature: 4000K; other color temperatures available on demand (2200K - 2700K - 3000K - 5000K.*

*Delivery time: 60 days)*

*Driver: included *

*Power factor  $\geq 0,95$*

*Protection: 5/10kV*

*Standard reference: IEC 61000-4-5; EN60598-1; EN60598-2-1; EN62471; EN62031; EN60598-2-5; EN61547*

La certificazione fotometrica dei nostri apparecchi viene sempre effettuata da un istituto esterno. Efficienza luminosa e "lm Output" sono quindi il risultato di tale istituto.

*The photometric certification of our appliances is always carried out by an external institute. Luminous efficiency and "lm Output" are therefore the result of this institute.*

A richiesta - On demand

**DYNA**  **1-10Vdc**

**Wireless** **DMX**

Vedi Pag. VI - See page VI



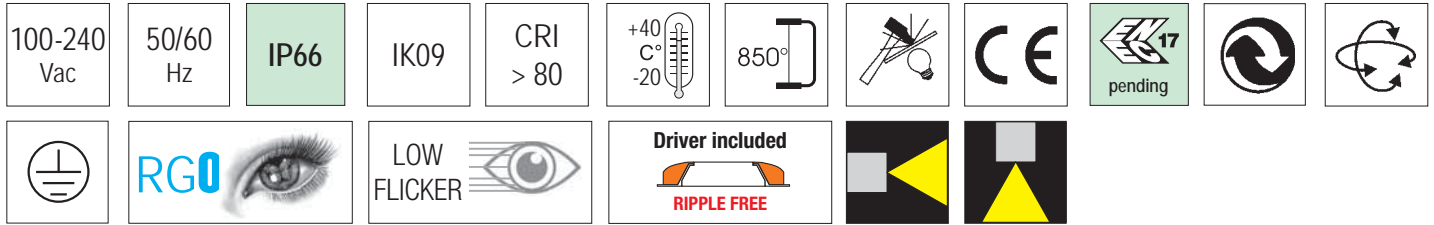

## LED Jaguaro 1

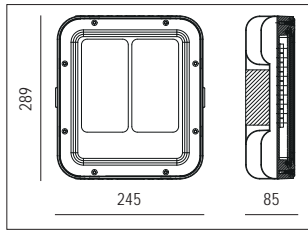

	colour	W	angle	K	nominal lm tc = 25°C	lm output	lm/W	pcs	Kg	CELL
	N	160	ASY 1	4000	26.200	23.200	145	1	4,50	29700
	N	160	35°	4000	26.200	23.200	145	1	4,50	29701
	N	160	90°	4000	26.200	23.200	145	1	4,50	29702
	N	200	ASY 1	4000	32.800	29.000	145	1	4,50	29700-180
	N	200	35°	4000	32.800	29.000	145	1	4,50	29701-180
	N	200	90°	4000	32.800	29.000	145	1	4,50	29702-180
	DALI 2	N	160	ASY 1	4000	26.200	23.200	1	4,50	29700-DA
	DALI 2	N	160	35°	4000	26.200	23.200	1	4,50	29701-DA
	DALI 2	N	160	90°	4000	26.200	23.200	1	4,50	29702-DA
	DALI 2	N	200	ASY 1	4000	32.800	29.000	145	4,50	29700-180-DA
	DALI 2	N	200	35°	4000	32.800	29.000	1	4,50	29701-180-DA
	DALI 2	N	200	90°	4000	32.800	29.000	1	4,50	29702-180-DA

## LED Jaguaro 2

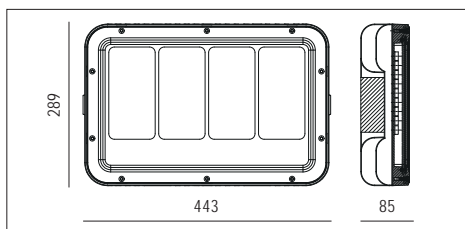
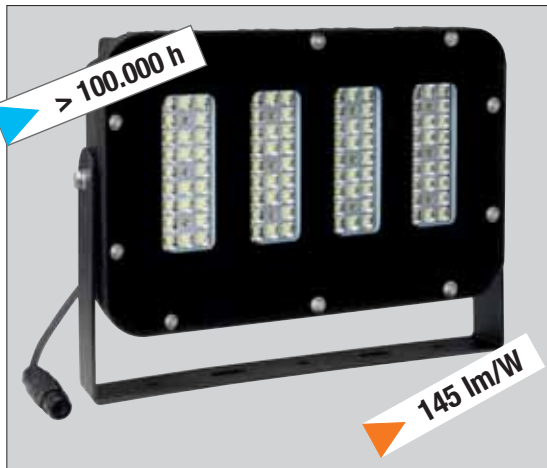

	colour	W	angle	K	nominal lm tc = 25°C	lm output	lm/W	pcs	Kg	CELL
	N	320	ASY 1	4000	52.400	46.400	145	1	9,00	29713
	N	320	35°	4000	52.400	46.400	145	1	9,00	29714
	N	320	90°	4000	52.400	46.400	145	1	9,00	29715
	N	400	ASY 1	4000	65.500	58.000	145	1	10,00	29713-400
	N	400	35°	4000	65.500	58.000	145	1	10,00	29714-400
	N	400	90°	4000	65.500	58.000	145	1	10,00	29715-400
	N	400	35°	5700	65.500	58.000	145	1	10,00	29714-400-5K
	DALI 2	N	320	ASY 1	4000	52.400	46.400	1	9,00	29713-DA
	DALI 2	N	320	35°	4000	52.400	46.400	1	9,00	29714-DA
	DALI 2	N	320	90°	4000	52.400	46.400	1	9,00	29715-DA
	DALI 2	N	400	ASY 1	4000	65.500	58.000	1	10,00	29713-400-DA
	DALI 2	N	400	35°	4000	65.500	58.000	1	10,00	29714-400-DA
	DALI 2	N	400	90°	4000	65.500	58.000	1	10,00	29715-400-DA

# LED Jaguaro



Il sistema di dissipazione del calore è realizzato per garantire un perfetto funzionamento dei LED e di conseguenza un'elevata durata di vita.

*The heat dissipation system is designed to ensure perfect operation of the LEDs and consequently a long lifespan.institute.*

## Ottiche standard - Standard optics

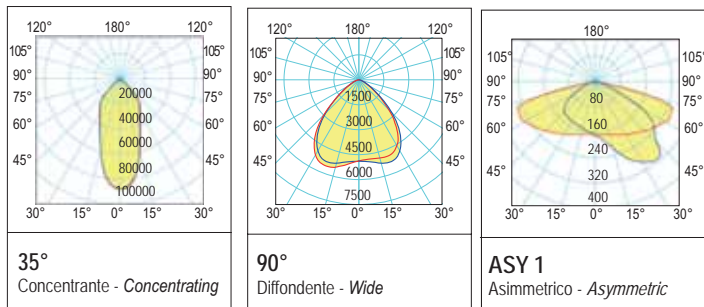

## Ottiche a richiesta - On demand optics

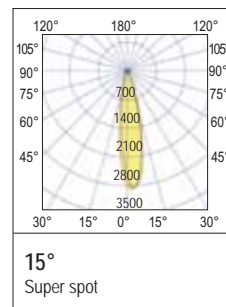

Floodlight

## On demand Suspended

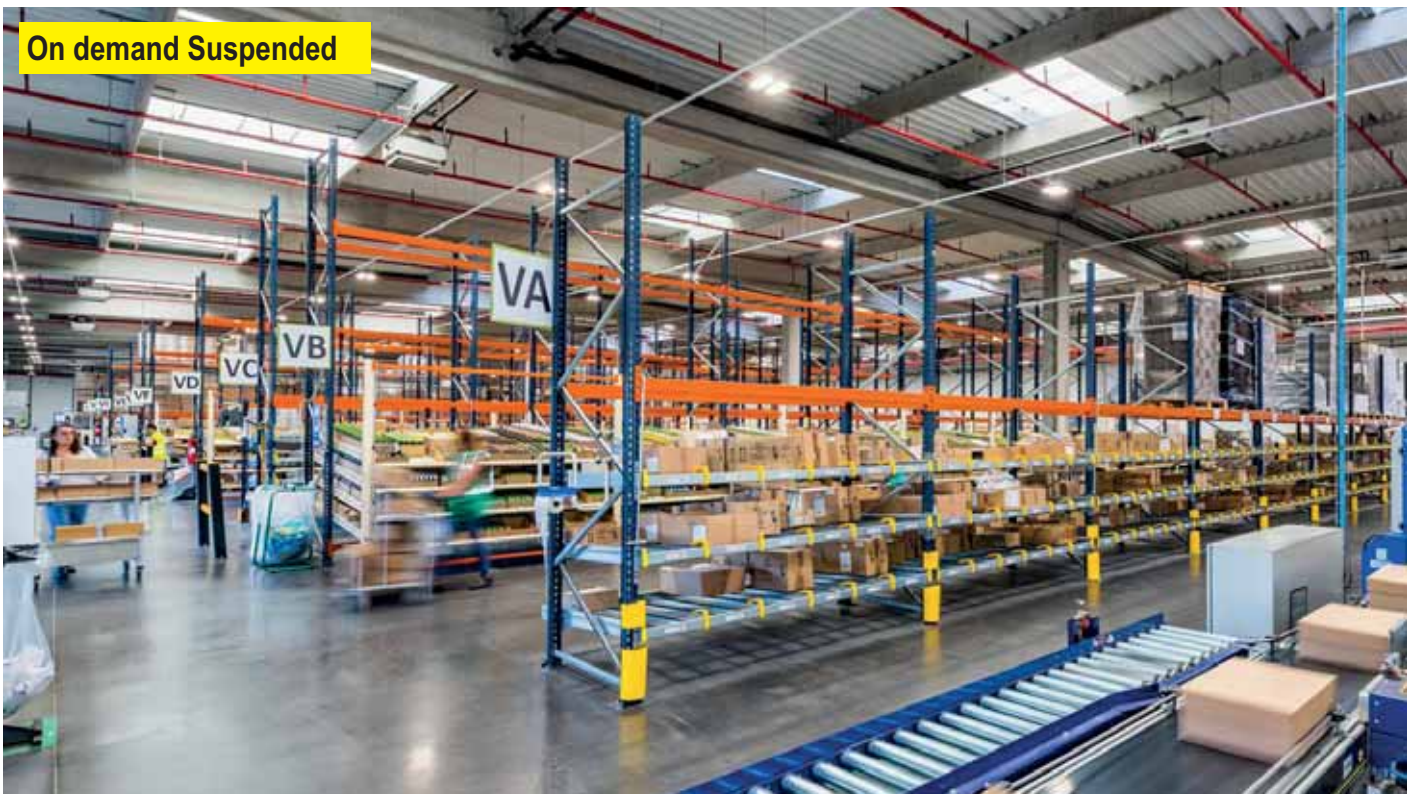

# LED Jaguaro



Floodlight





La certificazione fotometrica dei nostri apparecchi viene sempre effettuata da un istituto esterno. Efficienza luminosa e "lm Output" sono quindi il risultato di tale istituto.

*The photometric certification of our appliances is always carried out by an external institute. Luminous efficiency and "lm Output" are therefore the result of this institute.*

A richiesta - On demand

DMX

Wireless

Vedi Pag. VI - See page VI

Il LED Milano Sport è un proiettore per l'illuminazione di stadi e strutture sportive, grandi infrastrutture (aeroporti, stazioni, ecc.), aree di parcheggio, zone di stoccaggio (industriali, portuali, ecc.).

La particolare forma permette di avere diverse potenze e fasci luminosi stretti e precisi, specifici per l'installazione a notevole altezza. La qualità delle parti elettroniche e del corpo lampada e dei materiali assicurano sicurezza in fase di esercizio nelle condizioni ambientali più critiche.

**Installazione:** su palo o a parete

**Corpo e telaio:** alluminio pressofuso

**Staffa di fissaggio:** in acciaio zincato a caldo, con goniometro graduato per un corretto puntamento del fascio luminoso

**Verniciatura:** speciale eseguita a polvere, resistente agli agenti atmosferici e alla corrosione e alle nebbie. Colore Grigio RAL 9007.

**Ottica:** in policarbonato metallizzato

**Schermo:** vetro temperato ultra-white resistente agli shock termici e agli urti 4mm

**Sorgente:** LED LUMILEDS 5050  
 Mantenimento del flusso luminoso minimo al 70%: 80.000h (L70B20) per l'80% dei LED.

**Temperatura di colore:** 5700K (CRI 90) specifica per gli impianti con riprese televisive o 4000K (CRI 80);

**Driver LED multipotenza DALI 2:**

Certificato 

Fattore di potenza:  $\geq 0,95$

Wide range 100÷277V

**Surge protection:**

common mode 10kV

differential mode 6kV

**Norme di riferimento**

EN60598-1; EN60598-2-1; EN62471; EN62031

EN60598-2-5; EN61547

*LED Milano Sport is a projector for indoor and outdoor stadiums and sports grounds, large infrastructures (airports, stations, etc.), parking areas and storage areas (on industrial premises, at ports, etc.).*

*Different light intensities and narrow and precise light beams are possible due to the special design of the lamp body and light source, specifically for installation at a considerable height. The quality of the electronic parts, lamp body and materials ensure operating safety under even the most critical of environmental conditions.*

*Installation: on pole or wall*

*Housing and frame: die-cast aluminium*

*Fitting stirrup: in hot galvanised steel with graduated goniometer for correct pointing of the light beam*

*Painting: special powder coating, resistant to atmospheric agents, corrosion and mists. Grey RAL 9007.*

*Optics: concentrator and asymmetric optics*

*Screen: ultra-white thermal shock and collision resistant tempered glass.*

*Source: LED LUMILEDS 5050*

*Maintenance of 70% minimum luminous flux: 80,000h (L70B20) for 80% of the LEDs.*

*Color temperature: 5700K (CRI 90) specific for systems with television footage or 4000K (CRI 80);*

*Driver LED multipower DALI 2:*

*Certified *

*Power factor:  $\geq 0,95$*

*Wide range: 100÷277V*

**Surge protection:**

common mode 10kV

differential mode 6kV

**Standard reference**

EN60598-1; EN60598-2-1; EN62471; EN62031

EN60598-2-5; EN61547

# LED Milano Sport

EN  
EC 03



**TLCI** (indice di coerenza dell'illuminazione TV) la versione ad alta resa cromatica di Milano Sport con CRI 95 è classificata in termini di TLCI per soddisfare gli standard di ripresa televisiva HD dato il suo crescente utilizzo nell'ambiente delle trasmissioni televisive.

**TLCI** (TV Illumination Coherence Index) the high color rendering version of Milano Sport with CRI 95 is rated in terms of TLCI to meet HD television filming standards given its increasing use in the television broadcast environment.

La serie Milano Sport può essere equipaggiata con driver compatibili DMX. Il protocollo DMX è necessario per l'illuminazione dinamica grazie al suo tempo di reazione immediato e al numero praticamente illimitato di indirizzi. Il protocollo DMX può essere utilizzato anche nella dimmerazione quando si eseguono alcuni controlli di illuminazione negli impianti sportivi. DMX consente l'intera gamma di effetti scenici, oltre al monitoraggio di ciascun apparecchio e alla facilità di configurazione grazie alle funzioni di indirizzamento automatico DXM/RDM.

*The Milano Sport series can be equipped with DMX compatible drivers. The DMX protocol is necessary for dynamic lighting due to its immediate reaction time and virtually unlimited number of addresses. The DMX protocol can also be used in dimming when performing certain lighting controls in sports facilities. DMX allows the full range of stage effects, as well as monitoring of each luminaire and ease of configuration thanks to the DXM/RDM auto-addressing functions.*



# LED Milano Sport



Floodlight





100-277 Vac	50/60 Hz	IP66	IK08	+50 C -20	850°		CE				
 RG0	LOW FLICKER	Driver included  RIPPLE FREE					<b>EMC IMQ Tested</b>				

## LED Milano Sport 1

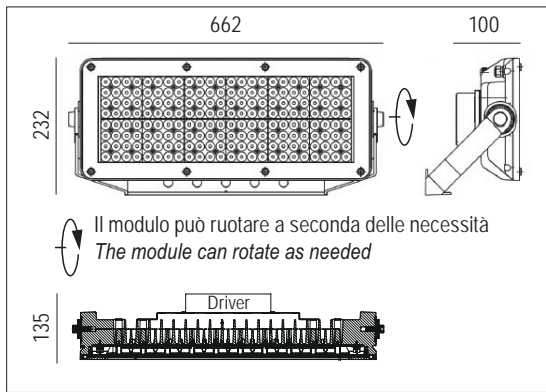

	colour	W	angle	K	CRI	nominal Im tc = 25°C	Im output	lm/W	pcs	Kg	CELL
	G	400	15°	4000	80	65.500	58.000	145	1	11,00	MI-400-15-4K
	G	400	25°	4000	80	65.500	58.000	145	1	11,00	MI-400-25-4K
	G	400	40°	4000	80	65.500	58.000	145	1	11,00	MI-400-40-4K
	G	400	ASY	4000	80	65.500	58.000	145	1	11,00	MI-400-ASY-4K
	G	400	15°	5700	95	39.500	44.000	110	1	11,00	MI-400-15-6K
	G	400	25°	5700	95	39.500	44.000	110	1	11,00	MI-400-25-6K
	G	400	40°	5700	95	39.500	44.000	110	1	11,00	MI-400-40-6K
	G	400	ASY	5700	95	39.500	44.000	110	1	11,00	MI-400-ASY-6 K

**A richiesta:** disponibilità di varie ottiche - **On request:** availability of various optics

## LED Milano Sport 2



	colour	W	angle	K	CRI	nominal Im tc = 25°C	Im output	lm/W	pcs	Kg	CELL
	G	600	15°	4000	80	98.300	87.000	145	1	25,00	MI-600-15-4K
	G	600	25°	4000	80	98.300	87.000	145	1	25,00	MI-600-25-4K
	G	600	40°	4000	80	98.300	87.000	145	1	25,00	MI-600-40-4K
	G	600	ASY	4000	80	98.300	87.000	145	1	25,00	MI80ASY4K600W
	G	600	15°	5700	95	72.500	66.000	110	1	25,00	MI-600-15-6K
	G	600	25°	5700	95	72.500	66.000	110	1	25,00	MI-600-25-6K
	G	600	40°	5700	95	72.500	66.000	110	1	25,00	MI-600-40-6K
	G	600	ASY	5700	95	72.500	66.000	110	1	25,00	MI-600-ASY-6K
	G	800	15°	4000	80	131.000	116.000	145	1	25,00	MI-800-15-4K
	G	800	25°	4000	80	131.000	116.000	145	1	25,00	MI-800-25-4K
	G	800	40°	4000	80	131.000	116.000	145	1	25,00	MI-800-40-4K
	G	800	ASY	4000	80	131.000	116.000	145	1	25,00	MI-800-ASY-4K
	G	800	15°	5700	95	96.600	88.000	110	1	25,00	MI-800-15-6K
	G	800	25°	5700	95	96.600	88.000	110	1	25,00	MI-800-25-6K
	G	800	40°	5700	95	96.600	88.000	110	1	25,00	MI-800-40-6K
	G	800	ASY	5700	95	96.600	88.000	110	1	25,00	MI-800-ASY-6K

**A richiesta:** disponibilità di varie ottiche - **On request:** availability of various optics

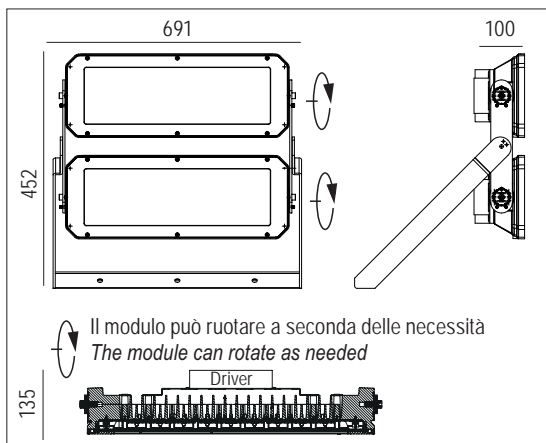

## LED Milano Sport 3

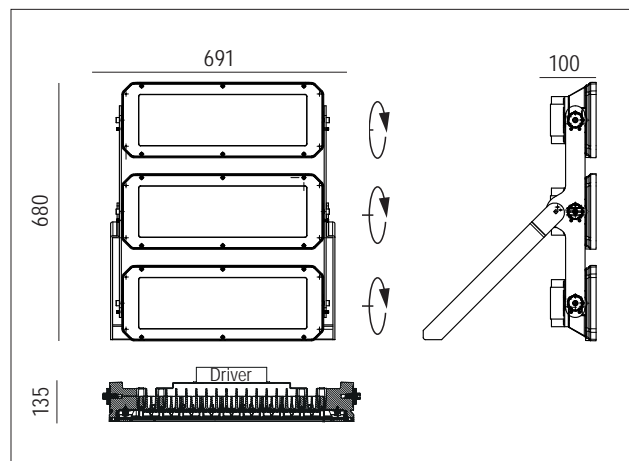

	colour	W	angle	K	CRI	nominal lm tc = 25°C	lm output	lm/W	pcs	Kg	CELL
<b>DALI 2</b>	G	1.200	15°	4000	80	196.600	174.000	145	1	42,00	MI-1200-154K
<b>DALI 2</b>	G	1.200	25°	4000	80	196.600	174.000	145	1	42,00	MI-1200-254K
<b>DALI 2</b>	G	1.200	40°	4000	80	196.600	174.000	145	1	42,00	MI-1200-404K
<b>DALI 2</b>	G	1.200	ASY	4000	80	196.600	174.000	145	1	42,00	MI-1200-ASY4K
<b>DALI 2</b>	G	1.200	15°	5700	95	145.200	132.000	110	1	42,00	MI-1200-156K
<b>DALI 2</b>	G	1.200	25°	5700	95	145.200	132.000	110	1	42,00	MI-1200-256K
<b>DALI 2</b>	G	1.200	40°	5700	95	145.200	132.000	110	1	42,00	MI-1200-406K
<b>DALI 2</b>	G	1.200	ASY	5700	95	145.200	132.000	110	1	42,00	MI-1200-ASY6K

**A richiesta:** disponibilità di varie ottiche  
**On request:** availability of various optics

## LED Milano Sport 4

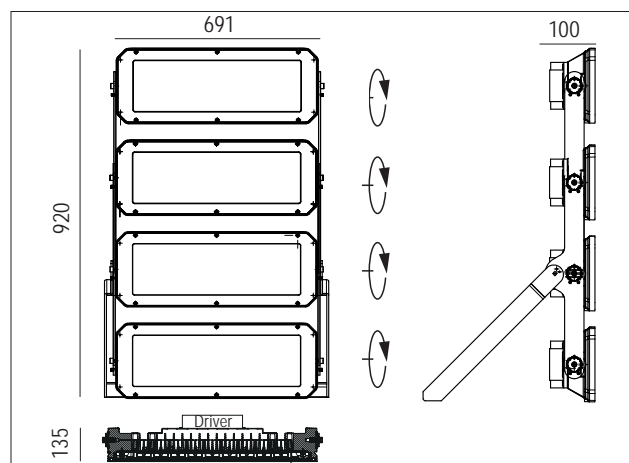

	colour	W	angle	K	CRI	nominal lm tc = 25°C	lm output	lm/W	pcs	Kg	CELL
<b>DALI 2</b>	G	1.600	15°	4000	80	255.200	232.000	145	1	57,00	MI-1600-154K
<b>DALI 2</b>	G	1.600	25°	4000	80	255.200	232.000	145	1	57,00	MI-1600-254K
<b>DALI 2</b>	G	1.600	40°	4000	80	255.200	232.000	145	1	57,00	MI-1600-404K
<b>DALI 2</b>	G	1.600	ASY	4000	80	255.200	232.000	145	1	57,00	MI-1600-ASY4K
<b>DALI 2</b>	G	1.600	15°	5700	95	193.600	176.000	110	1	57,00	MI-1600-156K
<b>DALI 2</b>	G	1.600	25°	5700	95	193.600	176.000	110	1	57,00	MI-1600-256K
<b>DALI 2</b>	G	1.600	40°	5700	95	193.600	176.000	110	1	57,00	MI-1600-406K
<b>DALI 2</b>	G	1.600	ASY	5700	95	193.600	176.000	110	1	57,00	MI-1600-ASY6K

**A richiesta:** disponibilità di varie ottiche  
**On request:** availability of various optics

# LED Milano Sport

Luce di alta qualità per riprese TV in HD - High quality light for HD TV shoots

Vetro ultra bianco  
Ultra-white glass

Alluminio di elevata purezza  
High purity aluminium

Accessorio puntatore laser  
Laser pointer accessory  
Code: 35500/LAS

Accessorio staffa testa palo  
Pole head bracket accessory  
Code: 35500/STF

Staffa di fissaggio ruotabile con goniometro.  
Doppia vite blocca-staffa per resistenza al vento.  
Rotating support with goniometer and double bracket blocking screws against the wind.

Floodlight

## Ottiche di serie - Standard optics

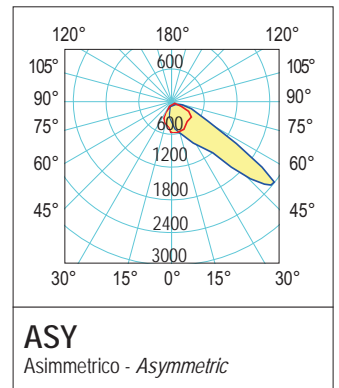
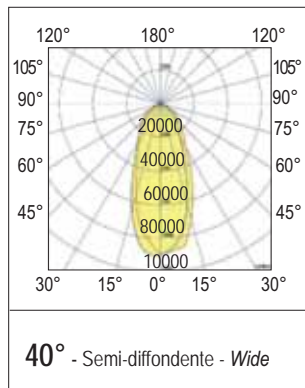
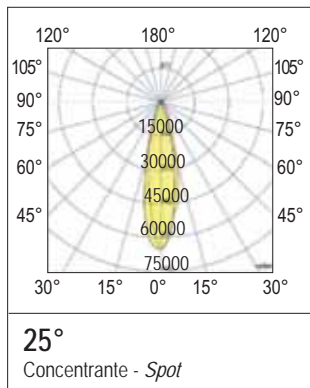
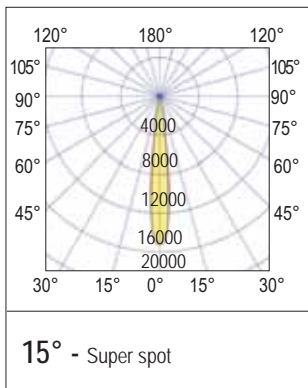

## Applicazioni - Applications

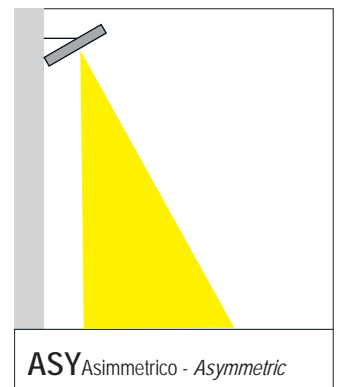
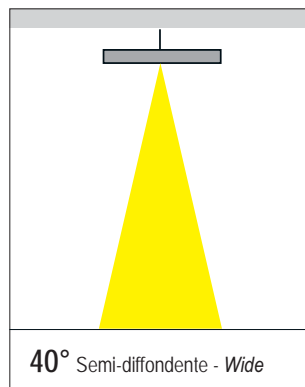
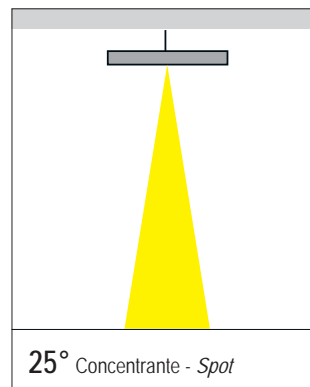
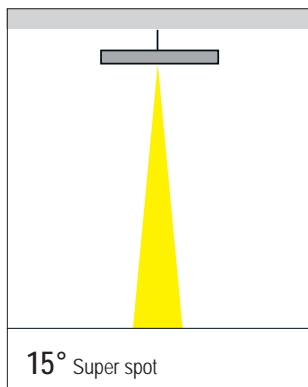



## LED Milano Sport



Floodlight



Il sistema di dissipazione del calore è appositamente realizzato per permettere il funzionamento dei LED con temperature idonee e garantire ottime prestazioni/rendimento ed un'elevata durata.

*The heat dissipation system is designed to permit use of the LEDs at suitable temperatures and to guarantee excellent efficiency/performance and a long lifespan.*

## LED Lampo serie



A richiesta - On demand



Vedi Pag. VI - See page VI

Innovativi proiettori a LED progettati per illuminare campi sportivi, stadi, aree di parcheggio, aeroporti e grandi aree in genere.

**Installazione:** sospensione, parete/plafone e testa palo (completo di staffa di fissaggio).

**Corpo e telaio:** in alluminio e acciaio verniciato con polvere termoindurente poliestere.

**Staffa di fissaggio:** in acciaio, verniciata con polvere termoindurente poliestere

**Verniciatura:** di tipo poliestere eseguita a polvere, resistente agli agenti atmosferici e alla corrosione marina. Colore Grigio RAL 9007.

**Ottica:** concentrante, semi concentrante, diffondente e asimmetrica.

**Lenti:** PMMA autoestinguenti antiurto

**Sorgente:** LED SMD 5050

**Temperatura di colore:** 4000K; a richiesta (2200K - 2700K - 3000K - 5000K - Consegna 90 giorni).

**Protezione alle sovratensioni inclusa:**

Modo differenziale 6kV (L-N)

Modo comune 10kV (L-GND, N-GND, L&N-GND)

Mantenimento del flusso luminoso minimo al 80% - 50.000h (L80B10) per il 90% dei LED.

**LED Driver:** 

Conforme alla Norma: IEC 61000-4-5.

Fattore di potenza:  $\geq 0,98$

**Norme di riferimento:** IEC 61000-4-5; EN60598-1; EN60598-2-1; EN62471; EN62031; EN60598-2-5; EN61547

*Innovative LED projectors designed to light up sport fields, stadiums, car parks, airports and wide spaces in general.*

*Installation: on vertical and horizontal surfaces (complete with fixing bracket)*

*Housing and frame: made by UNI EN 1706 die-cast aluminium, coated with polyester thermoset powder.*

*Fixing bracket: made by stainless steel, coated with polyester thermoset powder, with graduated goniometer to allow the correct orientation of light beam*

*Coating: coated with powdered polyester, resistant to atmospheric agents and marine corrosion.*

*Grey colour RAL 9007*

*Optic: clumping, semi-clumping, diffused and asymmetric*

*Shield: tempered glass with 4mm thickness resistant to thermal shocks and collisions*

*Light source: LED **SAMSUNG***

*Color temperature: 4000K; on demand (2200K - 2700K - 3000K - 5000K. Delivery time: 60 days)*

*Protection against overvoltages included:*

*Differential mode 6kV (L-N)*

*Standard mode 10kV (L - GND, N-GND, L&N-GND).*

*Maintenance of minimum luminous flux to 80% - 50.000h (L80B10) for 90% of LED.*

*LED Driver: *

*Conforming to IEC 61000-4-5.*

*Power factor:  $\geq 0,98$*

*Standard reference: IEC 61000-4-5; EN60598-1; EN60598-2-1; EN62471; EN62031; EN60598-2-5; EN61547*



## LED Lampo serie





100-240 Vac	110 Vac On demand	50/60 Hz	IP66	IK10	CRI > 80	+40 C -40	850°				CE
	RG0	LOW FLICKER	Driver included  RIPPLE FREE								

## LED Lampo 2

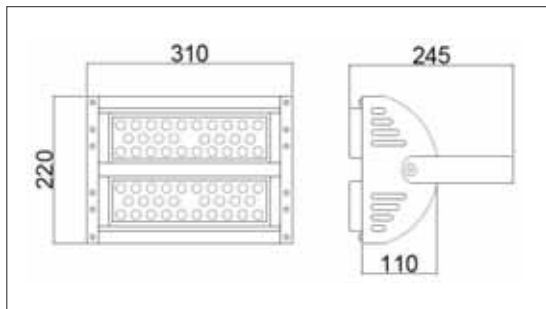

colour	W	angle	K	nominal lm tc = 25°C	lm output	lm/W	pcs	Kg	CELL
G	120	25°	4000	23.750	20.650	172	1	2,90	RFL120254K
G	120	40°	4000	23.750	20.650	172	1	2,90	RFL120404K
G	120	60°	4000	23.750	20.650	172	1	2,90	RFL120604K
G	120	60°	3000	23.750	20.650	172	1	2,90	RFL120603K
G	120	ASY	4000	23.750	20.650	172	1	2,90	RFL120ASY4K

## LED Lampo 3

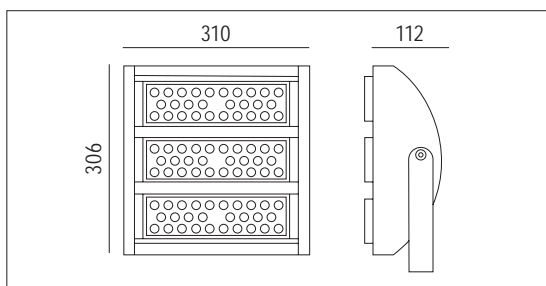

colour	W	angle	K	nominal lm tc = 25°C	lm output	lm/W	pcs	Kg	CELL
G	180	25°	4000	35.600	31.000	172	1	3,60	RFL180254K
G	180	40°	4000	35.600	31.000	172	1	3,60	RFL180404K
G	180	40°	4000	35.600	31.000	172	1	3,60	RFL180404KDA
G	180	60°	4000	35.600	31.000	172	1	3,60	RFL180604K
G	180	60°	3000	35.600	31.000	172	1	3,60	RFL180603K
G	180	ASY	4000	35.600	31.000	172	1	3,60	RFL180ASY4K

## LED Lampo 4

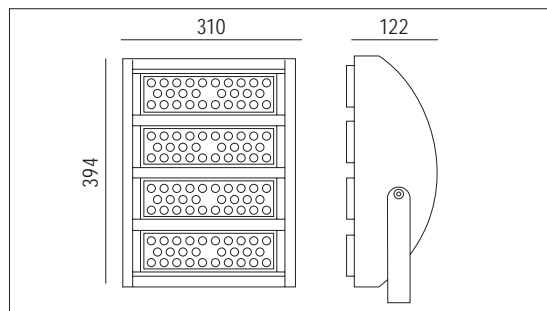

colour	W	angle	K	nominal lm tc = 25°C	lm output	lm/W	pcs	Kg	CELL
G	240	25°	4000	47.500	41.300	172	1	5,40	RFL240254K
G	240	40°	4000	47.500	41.300	172	1	5,40	RFL240404K
G	240	60°	4000	47.500	41.300	172	1	5,40	RFL240604K
G	240	60°	3000	47.500	41.300	172	1	5,40	RFL240603K
G	240	ASY	4000	47.500	41.300	172	1	5,40	RFL240ASY4K

## LED Lampo 6

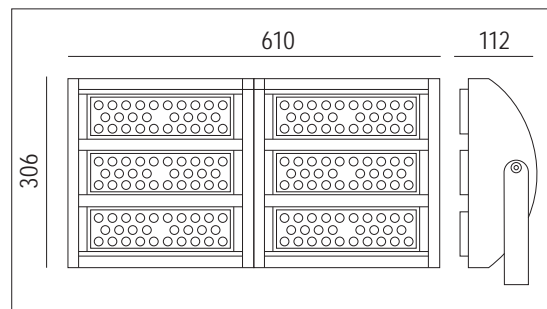

colour	W	angle	K	nominal lm tc = 25°C	lm output	lm/W	pcs	Kg	CELL
G	240	10°	4000	47.500	41.300	172	1	7,50	RFL350104K
G	350	25°	4000	70.000	60.200	172	1	7,50	RFL350254K
G	350	40°	4000	70.000	60.200	172	1	7,50	RFL350404K
G	350	40°	4000	70.000	60.200	172	1	7,50	RFL350404KDA
G	350	60°	4000	70.000	60.200	172	1	7,50	RFL350604K
G	350	ASY	4000	70.000	60.200	172	1	7,50	RFL350ASY4K
G	350	ASY	4000	70.000	60.200	172	1	7,50	RFL350ASY4KDA

## LED Lampo 10

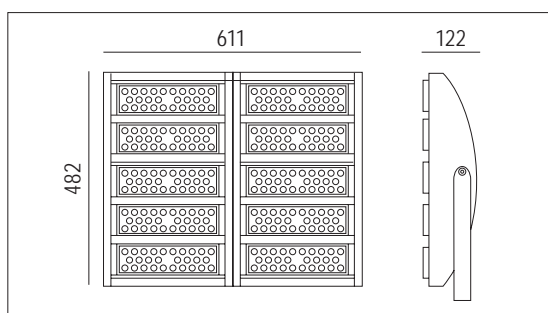

## LED Lampo 12

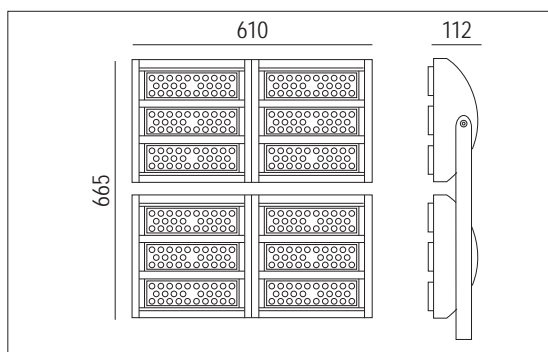

colour	W	angle	K	nominal Im tc = 25°C	Im output	lm/W	pcs	Kg	CELL	
G	400	10°	4000	77.700	68.800	172	1	16,00	RFL500104K	
G	500	25°	4000	97.200	86.000	172	1	16,00	RFL500254K	
G	500	40°	4000	97.200	86.000	172	1	16,00	RFL500404K	
<b>DALI 2</b>	G	500	40°	4000	97.200	86.000	172	1	16,00	RFL500404KDA
G	500	60°	4000	97.200	86.000	172	1	16,00	RFL500604K	
G	500	60°	5000	97.200	86.000	172	1	16,00	RFL500605K	
<b>DALI 2</b>	G	500	60°	4000	97.200	86.000	172	1	16,00	RFL500604KDA
G	500	ASY	4000	97.200	86.000	172	1	16,00	RFL500ASY4K	



colour	W	angle	K	nominal Im tc = 25°C	Im output	lm/W	pcs	Kg	CELL
G	480	10°	4000	93.300	82.600	172	1	20,00	RFL700104K
G	700	25°	4000	136.000	120.400	172	1	20,00	RFL700254K
G	700	40°	4000	136.000	120.400	172	1	20,00	RFL700404K
G	700	60°	4000	136.000	120.400	172	1	20,00	RFL700604K
G	700	ASY	4000	136.000	120.400	172	1	20,00	RFL700ASY4K
G	700	ASY	3000	136.000	120.400	172	1	20,00	RFL700ASY3K

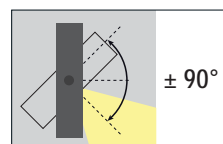

Rotazione gruppo ottiche  $\pm 90^\circ$   
(ogni gruppo è indipendente)  
Optical group rotation  $\pm 90^\circ$   
(each group is independent)



# LED Lampo 18



colour	W	angle	K	nominal lm tc = 25°C	lm output	lm/W	pcs	Kg	CELL
G	800	10°	4000	155.500	137.600	172	1	30,00	RFL1000104K
G	1000	25°	4000	194.350	172.000	172	1	30,00	RFL1000254K
G	1000	40°	4000	194.350	172.000	172	1	30,00	RFL1000404K
G	1000	60°	4000	194.350	172.000	172	1	30,00	RFL1000604K
G	1000	ASY	4000	194.350	172.000	172	1	30,00	RFL1000ASY4K

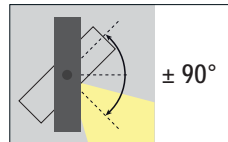
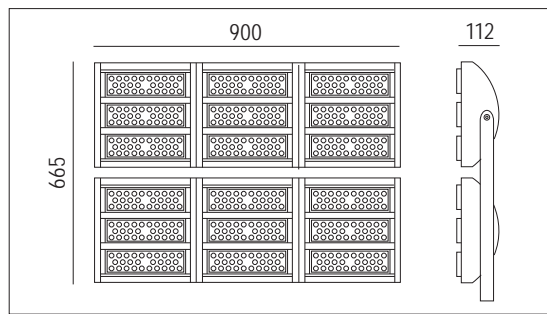

Rotazione gruppo ottiche  $\pm 90^\circ$   
 (ogni gruppo è indipendente)  
 Optical group rotation  $\pm 90^\circ$   
 (each group is independent)

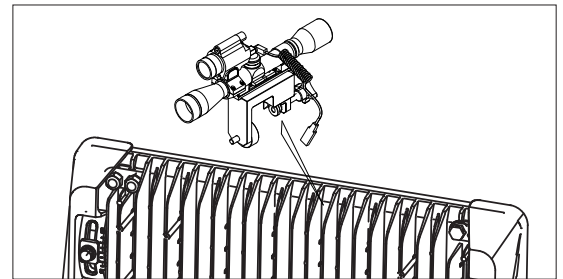

Accessorio puntatore laser  
 Laser point accessory

Floodlight



Luce solo all'occorrenza - *Light only when needed*



Cod. ES-M08A

Rilevatore di movimento a microonde con crepuscolare e stand-by regolabile, aggiungere Y dopo il codice  
Per maggiori informazioni vedi Pag. 20

*Microwave motion detector with crepuscular and dimmable stand-by, add Y after the code,  
For more information see Page 20*

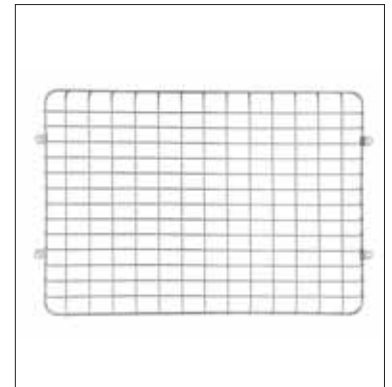
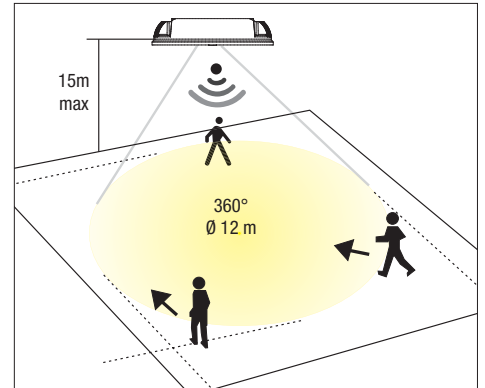

Cod. 703952.NEW

Attacco palo per l'installazione di 1 proiettore, Ø 60/76 mm.  
In ferro verniciato con polveri termoindurenti poliesteri resistenti alla corrosione ed agli agenti atmosferici.

*Pole attachment for the installation of 1 projector, size Ø 60/76 mm. Iron coated with polyester thermosetting powder coating, offering high resistance to rust and external atmospheric agents.*

Cod. CARTER1 (LED Lampo 120W)

Cod. CARTER2 (LED Lampo 180W)

Cod. CARTER3 (LED Lampo 240W)

Cod. CARTER4 (LED Lampo 350W - 2 moduli per LED Lampo 700W)

Cod. CARTER5 (LED Lampo 500W)

CARTER per un'ulteriore protezione

*CARTER for enhanced protection and design*

Cod. RETE140 (LED Lampo 120W)

Cod. RETE180 (LED Lampo 180W)

Cod. RETE240 (LED Lampo 240W)

Griglia di protezione - *Protection grid*

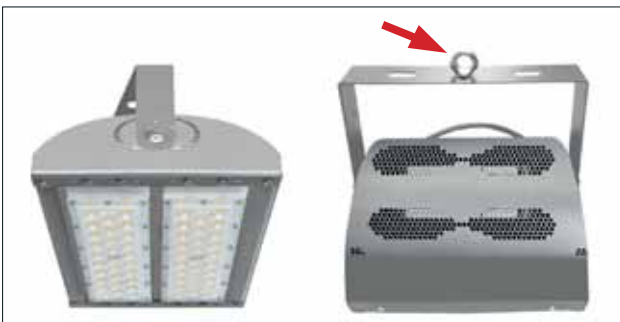

Cod. GFR100.000

Gancio per applicazione a sospensione

*Hook for suspension application*

Dettagli - *Details*



# LED Lampo serie

I lm/W della serie LED Lampo sono stati certificati da istituto esterno

The lm/W of the LED Lampo series have been certified by an external institute



## Apparecchio

Nome PROIETTORE LED LAMPO

Rilievo

Codice CL2255-18-15G2

Nome

Flusso Apparecchio	30.000 lm	Potenza Apparecchio	175 W	Efficacia	167 lm/W	Rendimento	100.03%
Flusso sorgente	30.000 lm	Valore Massimo	31.000 cd	Posizione	C=0.00 G=0.00	CG	Rotosimmetrico

## Ottiche di serie - Standard optics

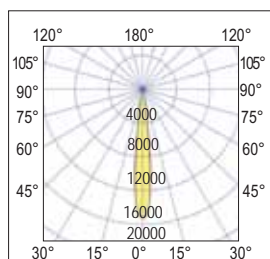

**10°**  
Super spot

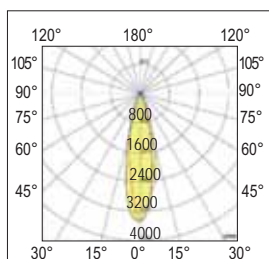

**25°**  
Concentrate - *Spot*

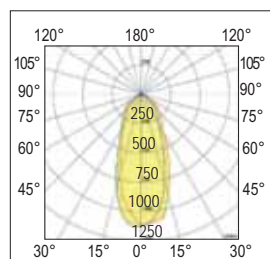

**40°**  
Semi-diffondente - *Wide*

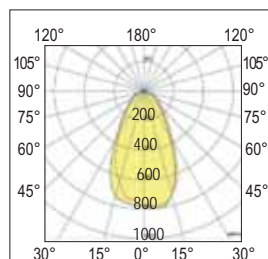

**60°**  
Diffondente - *Flood*

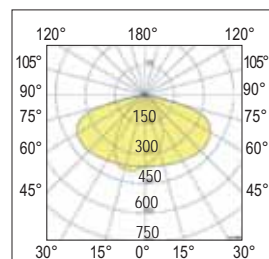

**ASY**  
Asimmetrico - *Asymmetric*

## Applicazioni - Applications

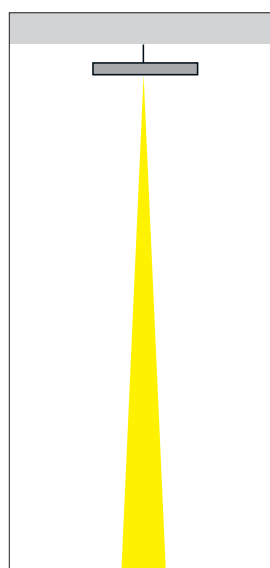

**10°**  
Super spot

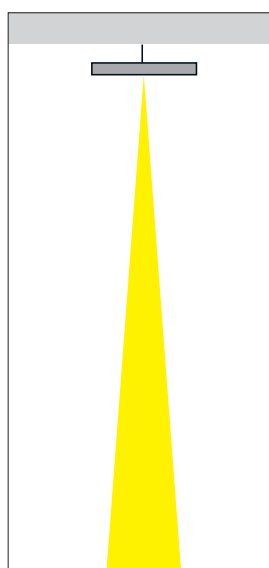

**25°**  
Concentrate - *Spot*

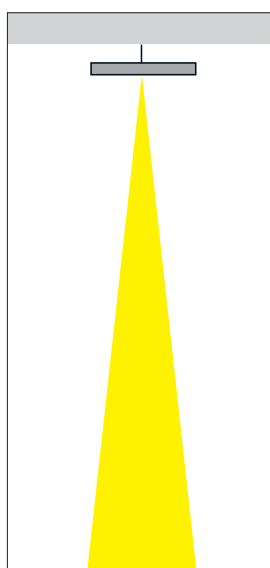

**40°**  
Semi-diffondente - *Wide*

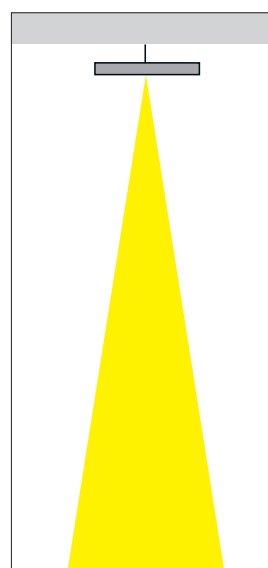

**60°**  
Diffondente - *Flood*

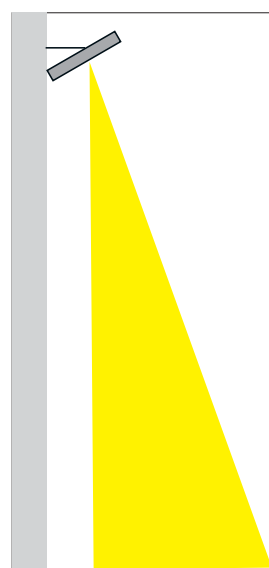

**ASY**  
Asimmetrico - *Asymmetric*





Apparecchi a LED professionali per l'illuminazione di gallerie e strade.

**Corpo:** in alluminio pressofuso, vetro temperato super bianco, riflettore in plastica cromata.

**Ottica:** con lente in PC con elevata visibilità confortevole e distribuzione uniforme della luce, molteplici opzioni di distribuzione della luce.

**Sorgente:** Chip LED di alta qualità, driver con opzioni 0-10V/DALI/programmate e con protezione da sovratensione fino a 20KV.

**Manutenzione:** Design della porta di manutenzione indipendente, facile installazione e manutenzione.

**Installazione:** parete o plafone

**Fissaggio:** L'apparecchio è fissato tramite staffa posteriore e l'angolazione può essere regolata.

**Viteria:** Tutte le viti esterne sono realizzate in acciaio inossidabile 304.

**Driver:** incorporato

**Schermo:** vetro temperato di spessore 4mm resistente agli shock termici e agli urti.

**Verniciatura:** di tipo poliestere eseguita a polvere, resistente agli agenti atmosferici e alla corrosione.

**Norme di riferimento:** nessun rischio fotobiologico (nessun rischio legato a infrarossi, luce blu e radiazioni UV) in conformità con EN 62471:2008.

Controllo dell'illuminazione stradale utilizzato con tecnologia di controllo intelligente.

Può essere compatibile con il sistema di gestione remota.

*Professional LED fixtures for tunnel and road lighting*

*Body: Die-casting aluminium body, super white tempered glass, Chrome plastic reflector.*

*Optics: Optics with PC lens with high visual comfortable and uniform lighting distribution, multiple light distribution options.*

*Source: High quality LED chips, Driver with 0-10V/DALI/programmed be options, and with surge protection up to 20KV.*

*Maintenance: Independent maintenance door design, easy installation and maintenance.*

*Installation: on the wall or ceiling*

*Fixing: The luminaire is fixed by back bracket, and angle can be adjusted.*

*Installation: on the wall or ceiling*

*Screws: All external screws are made of 304 stainless steel*

*Driver: included*

*Shield: tempered glass with 4mm thickness resistant to thermal shocks and collisions.*

*Coating: coated with powdered polyester, resistant to atmospheric agents, corrosion.*

*Standard reference: No photo-biological risk, (no risk linked to infrared, blue light and UV radiation) in accordance with EN 62471:2008.*

*Street lighting control used with smart control technology. It can be compatible with remote management system.*

A richiesta - On demand

1-10Vdc

DALI 2

Wireless

Vedi Pag. VI - See page VI

# LED Tunnel Evolution

**NEW**

220-240 Vac	110 Vac On demand	50/60 Hz	IP66	IK09	CRI > 70	+40 C° -30	650°				
			LOW FLICKER								

## LED Tunnel Evolution 1



A seconda dell'ottica scelta, aggiungere dopo il codice -T1, -T2, -T3 o -T4  
 Depending on the chosen optic, add after the code -T1, -T2, -T3 or -T4

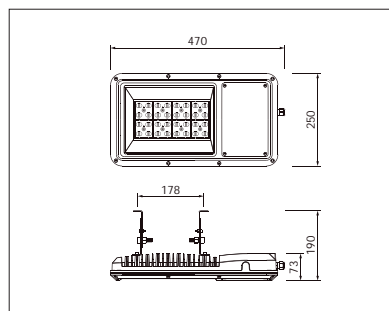

colour	LED Type	W	Optic	K	lm output	lm/W	pcs	Kg	CELL
G	LED CHIPS 5050	60	T1 / T2 / T3 / T4	4000	8.400	140	1	6,40	120SN604
G	LED CHIPS 5050	75	T1 / T2 / T3 / T4	4000	10.500	140	1	6,70	120SN75
G	LED CHIPS 5050	100	T1 / T2 / T3 / T4	4000	14.000	140	1	7,00	120SN100
	G	LED CHIPS 5050	60	T1 / T2 / T3 / T4	4000	8.400	1	6,40	120SN604DA
	G	LED CHIPS 5050	75	T1 / T2 / T3 / T4	4000	10.500	1	6,70	120SN75DA
	G	LED CHIPS 5050	100	T1 / T2 / T3 / T4	4000	14.000	1	7,00	120SN100DA

## LED Tunnel Evolution 2



A seconda dell'ottica scelta, aggiungere dopo il codice -T1, -T2, -T3 o -T4  
 Depending on the chosen optic, add after the code -T1, -T2, -T3 or -T4

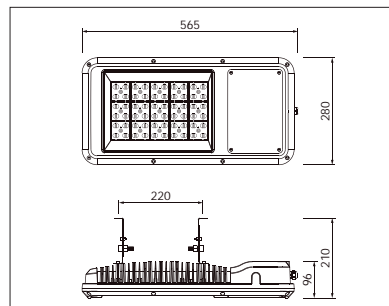

colour	LED Type	W	Optic	K	lm output	lm/W	pcs	Kg	CELL
G	LED CHIPS 5050	120	T1 / T2 / T3 / T4	4000	16.800	140	1	10,70	120MN120
G	LED CHIPS 5050	150	T1 / T2 / T3 / T4	4000	21.000	140	1	11,00	120MN150
G	LED CHIPS 5050	180	T1 / T2 / T3 / T4	4000	25.200	140	1	11,00	120MN180
	G	LED CHIPS 5050	120	T1 / T2 / T3 / T4	4000	16.800	1	10,70	120MN120DA
	G	LED CHIPS 5050	150	T1 / T2 / T3 / T4	4000	21.000	1	11,00	120MN150DA
	G	LED CHIPS 5050	180	T1 / T2 / T3 / T4	4000	25.200	1	11,00	120MN180DA

## Distribuzione dell'illuminazione - *Lighting distribution*

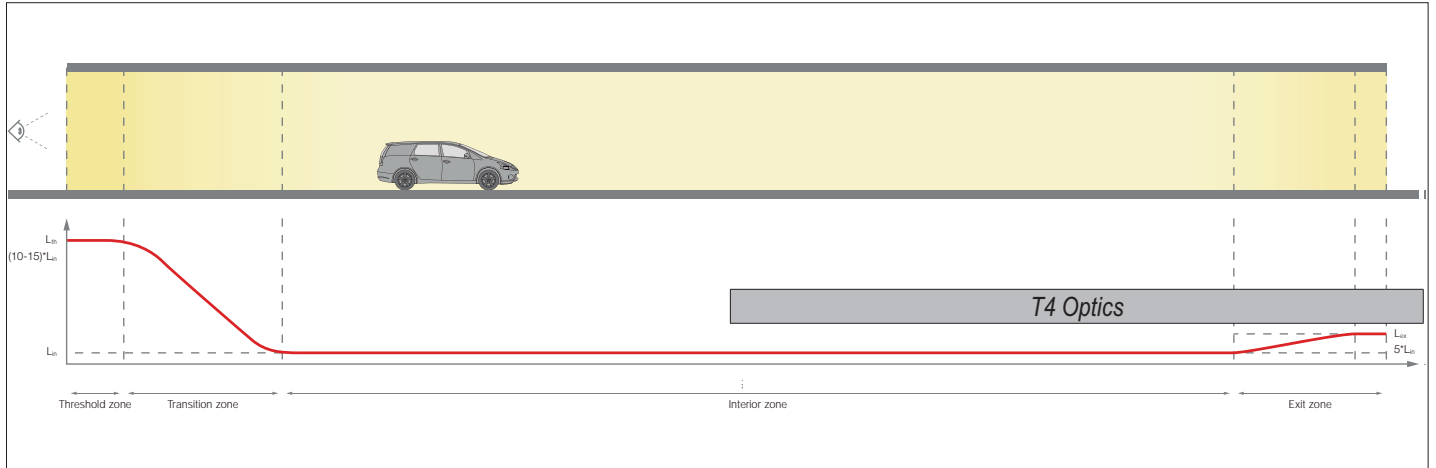

## Ottiche - *Optics*

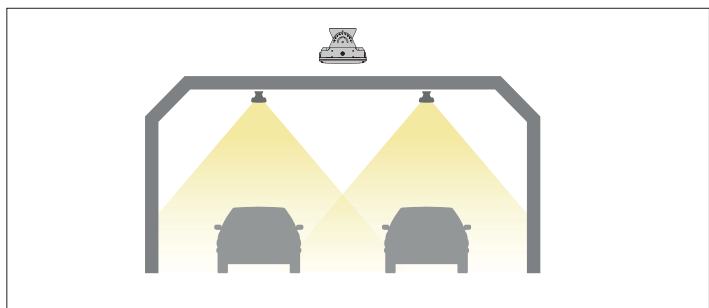
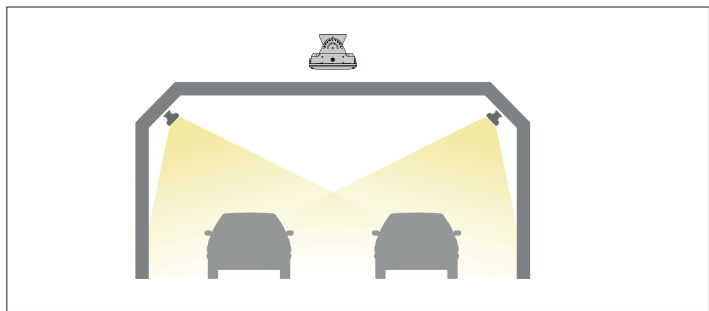
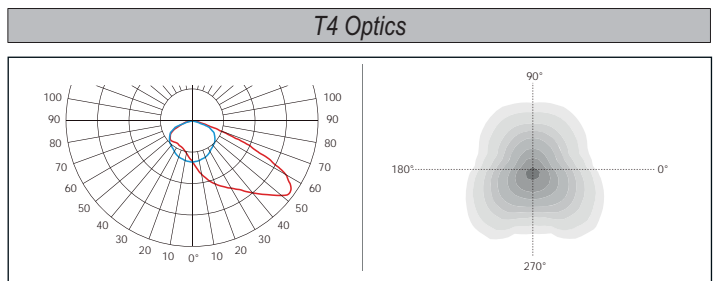
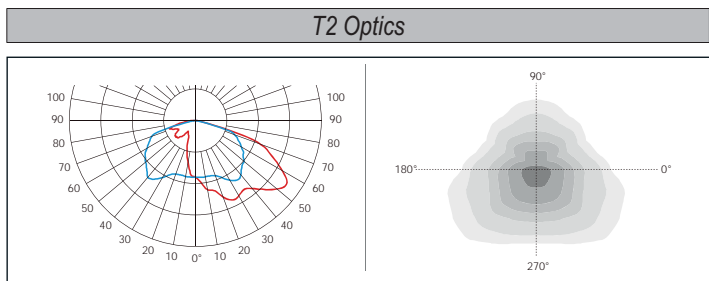
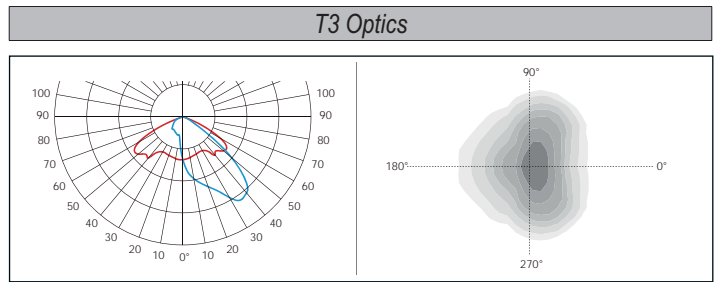
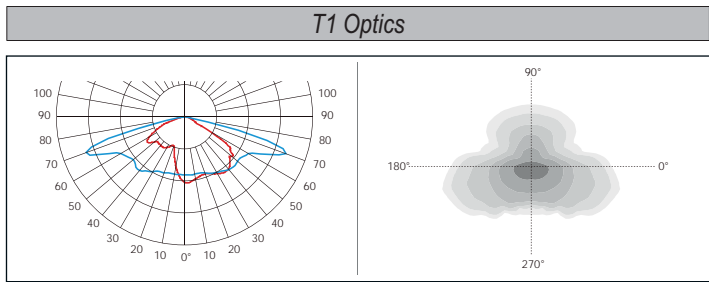

Floodlight



# LED Minizeus - LED Zeus



La certificazione fotometrica dei nostri apparecchi viene sempre effettuata da un istituto esterno. Efficienza luminosa e "lm Output" sono quindi il risultato di tale istituto.

*The photometric certification of our appliances is always carried out by an external institute. Luminous efficiency and "lm Output" are therefore the result of this institute.*

**A richiesta - On demand**

**Sensor DIM**  
1-10V

**Sensor DIM**  
DALI

**DALI 2**

**Wireless**

Vedi Pag. VI - See page VI

Gamma completa di proiettori da esterno ed interno ideale per illuminare parcheggi, piazzali, facciate, zone carico-scarico, centri commerciali e grandi aree in generale.

**Installazione:** a parete e a sospensione.

**Corpo e telaio:** in alluminio pressofuso UNI EN 1706.

**Staffa di fissaggio:** in metallo, verniciata con polvere termoindurente poliestere, con goniometro graduato per un corretto puntamento del fascio luminoso.

**Verniciatura:** di tipo poliestere eseguita a polvere, resistente agli agenti atmosferici, alla corrosione e alla nebbia salina. Grigio RAL 9007.

**Ottica:** concentrante, semi concentrante, diffondente, asimmetrica ed ellittica. In PMMA con resistenza alle alte temperature, agli shock termici e agli urti

**Schermo:** vetro temprato di spessore 4mm resistente agli shock termici e agli urti.

**Sorgente:** LED LUMILEDS 5050

Mantenimento del flusso luminoso minimo al 90% - 100.000h (L90B10) per il 90% dei LED.

**Temperatura di colore:** 4000K; altre temperature di colore a richiesta (2200K - 2700K - 3000K - 5000K - Consegna: 60 giorni).

**Driver:** incorporato 

Fattore di potenza  $\geq 0,95$ .

**Protezione alle sovratensioni inclusa:**

Modo differenziale 6kV (L-N)

Modo comune 8kV (L-GND, N-GND, L&N-GND)

**A richiesta:** versione con protezione maggiorata (10kV) contro gli impulsi aggiungendo il cod. RO0640/N (di serie in LED ZEUS).

**Norme di riferimento:** EN60598-1; EN60598-2-1; EN62471; EN62031; EN60598-2-5; EN61547

**LED Zeus 250W:** 110-240V

*Complete range of outdoor and indoor projectors perfect to light up car parks, squares, facades, loading and unloading areas, shopping centers and large areas in general.*

*Installation: on the wall and suspended.*

*Housing and frame: made by UNI EN 1706 die-cast aluminum.*

*Fixing bracket: made by metal, coated with polyester thermoset powder, with graduated goniometer to allow the correct orientation of light beam*

*Coating: coated with powdered polyester, resistant to atmospheric agents and corrosion and guaranteed in saline mist. RAL 9007 Grey.*

*Optic: clumping, semi-clumping, wired asymmetric and elliptical. PMMA optic with high temperature resistance, thermal shock and impact resistance*

*Shield: tempered glass with 4mm thickness resistant to thermal shocks and collisions.*

*Light source: LED LUMILEDS 5050*

*Maintenance of minimum luminous flux to 90% - 100.000h (L90B10) for 90% of LED.*

*Color temperature: 4000K; other color temperatures available on demand (2200K - 2700K - 3000K - 5000K - Delivery time: 60 days).*

**Driver:** included 

Power factor  $\geq 0,95$

**Protection against overvoltages included:**

Differential mode 6kV (L-N)

Standard mode 8kV (L - GND, N-GND, L&N-GND).

**On demand:** this version with greater protection (10kV) with code RO0640/N (Of series in LED Zeus).

**Standard reference:** EN60598-1; EN60598-2-1; EN62471; EN62031; EN60598-2-5; EN61547

**LED Zeus 250W:** 110-240V

# LED Minizeus - LED Zeus



**A richiesta:** versione conforme alla direttiva HACCP per gli impianti illuminotecnici nelle industrie alimentari

*On demand: HACCP directive for lighting systems in food industries version*

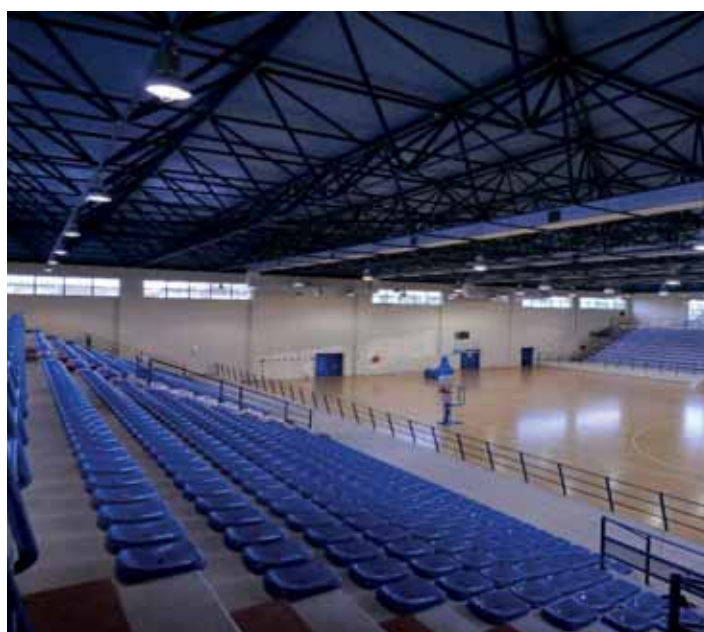



220-240 Vac	110 Vac On demand	50/60 Hz	IP66	IK09	CRI > 80	+40°C -25°C	850°		CE		
	RG0	LOW FLICKER	Driver included <b>MULTIPOWER RIPPLE FREE</b>		TECEE						

## LED Minizeus - LED Zeus

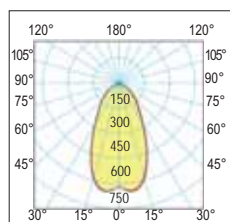
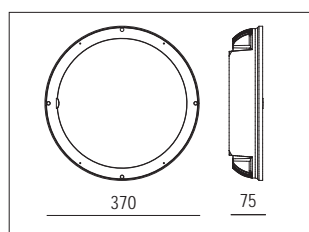

50°  
Intermedio - Medium

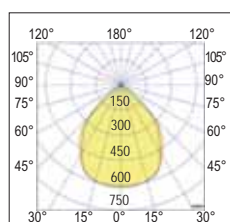

90°  
Diffondente - Wide

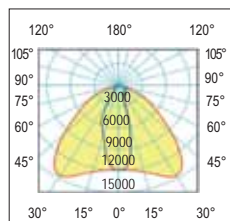

ELLIP  
Ellittica - Elliptical

colour	W	angle	K	nominal lm tc = 25°C	lm output	lm/W	pcs	Kg	CELL
G	75	50°	4000	10.900	10.875	145	1	4,50	354087.75
G	110	50°	4000	15.900	15.950	145	1	4,50	354087.100
G	150	50°	4000	24.600	21.750	145	1	4,50	354087150
G	150	50°	3000	24.600	21.750	145	1	4,50	3540871503
G	200	50°	4000	32.700	29.000	145	1	4,50	354087.200
G	75	90°	4000	10.900	10.875	145	1	4,50	354096.75
G	110	90°	4000	15.900	15.950	145	1	4,50	354096.100
G	150	90°	4000	24.600	21.750	145	1	4,50	354096150
G	150	90°	3000	24.600	21.750	145	1	4,50	3540961503
G	200	90°	4000	32.700	29.000	145	1	4,50	354096.200
G	200	90°	3000	32.700	29.000	145	1	4,50	354096.2003K

colour	W	angle	K	nominal lm tc = 25°C	lm output	lm/W	pcs	Kg	CELL
G	75	50°	4000	10.900	10.875	145	1	4,50	354087.75D
G	110	50°	4000	15.900	15.950	145	1	4,50	354087.100D
G	110	50°	4000	15.900	15.950	145	1	4,50	354087100DAEM
G	150	50°	4000	24.600	21.750	145	1	4,50	354087.150D
G	200	50°	4000	32.700	29.000	145	1	4,50	354087.200D
G	75	90°	4000	10.900	10.875	145	1	4,50	354096.75D
G	110	90°	4000	15.900	15.950	145	1	4,50	354096.100D
G	150	90°	4000	24.600	21.750	145	1	4,50	HE4096.150D
G	200	90°	4000	32.700	29.000	145	1	4,50	354096.200D
G	200	90°	3000	32.700	29.000	145	1	4,50	354096.200D3K

colour	W	angle	K	nominal lm tc = 25°C	lm output	lm/W	pcs	Kg	CELL
G	75	ELLIP	4000	10.900	10.875	145	1	4,50	354029.75E
G	110	ELLIP	4000	15.900	15.950	145	1	4,50	354029.100E
G	150	ELLIP	4000	24.600	21.750	145	1	4,50	HE4029.150E
G	75	ELLIP	4000	24.600	21.750	145	1	4,50	35402975ED
G	110	ELLIP	4000	24.600	21.750	145	1	4,50	354029100ED
G	150	ELLIP	4000	24.600	21.750	145	1	4,50	HE4029150ED



LED Minizeus: Accessori non inclusi - *Not included accessories*

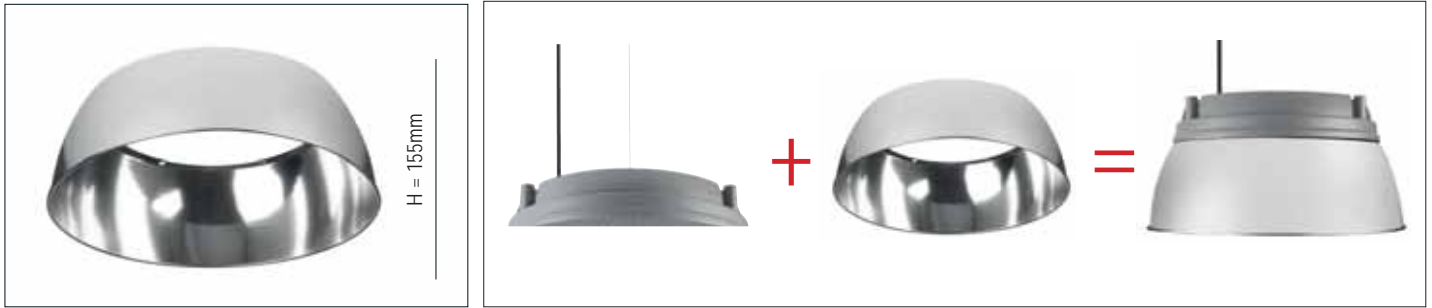

Cod: RF-60100

Riflettore in alluminio compreso di 4 viti 51804500 - *Aluminum reflector including 4 screws 51804500*



Floodlight

# LED Zeus

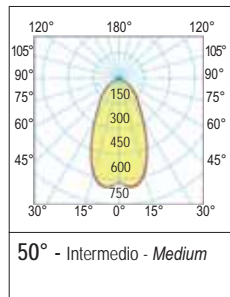
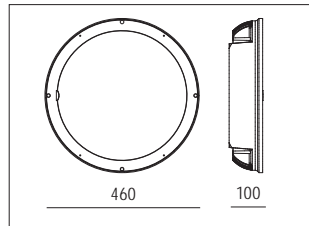

**DALI 2**

**DALI 2**

colour	W	angle	K	nominal lm tc = 25°C	lm output	lm/W	pcs	Kg	CELL
G	175	50°	4000	28.670	25.375	145	1	9,70	334087.185
G	175	90°	4000	28.670	25.375	145	1	9,70	334096.185
G	200	50°	4000	32.770	29.000	145	1	9,70	HE4087.210
G	250	50°	4000	40.900	36.250	145	1	9,70	HE4087.250
G	200	90°	4000	32.770	29.000	145	1	9,70	HE4096.210
G	250	90°	4000	40.900	36.250	145	1	9,70	HE4096.250
G	210	50°	4000	34.400	30.450	145	1	9,70	334087.210D
G	210	90°	4000	34.400	30.450	145	1	9,70	334096.210D

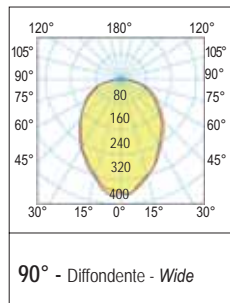

**DALI 2**

colour	W	angle	K	nominal lm tc = 25°C	lm output	lm/W	pcs	Kg	CELL
G	175	ELLIP	4000	28.670	25.375	145	1	9,70	334029.185E
G	200	ELLIP	4000	32.770	29.000	145	1	9,70	HE4029.210E
G	210	ELLIP	4000	34.400	30.450	145	1	9,70	334029210ED

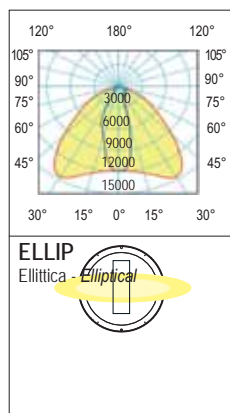

LED Minizeus e LED Zeus vengono forniti completi di gancio per applicazione a sospensione

LED Minizeus e LED Zeus comes complete with hook for application to suspension



Dispositivo anticondensa: valvola di compensazione e riciclo dell'aria.

Anti-condensate device: valve for compensation and circulation of air.



Completo di connettore IP68 per una rapida installazione

Complete with IP68 connector for quick installation

# LED Zeus - LED Minizeus

## LED Minizeus - LED Zeus: Accessori non inclusi - *Not included accessories*

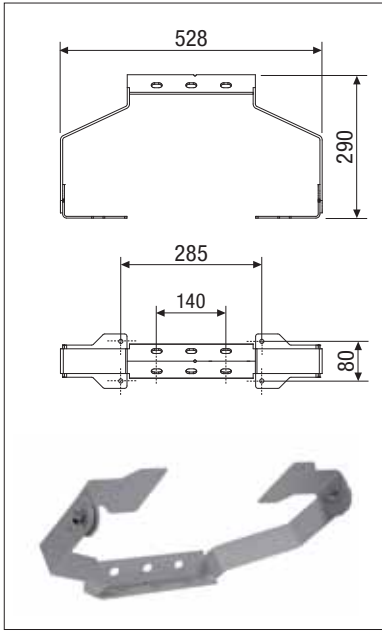

**Code:** 703959.0101

Staffa sagomata orientabile per montaggio a parete più goniometro per puntamento proiettore  
*Shaped adjustable bracket for wall mounting complete with protractor pointing to the projector*

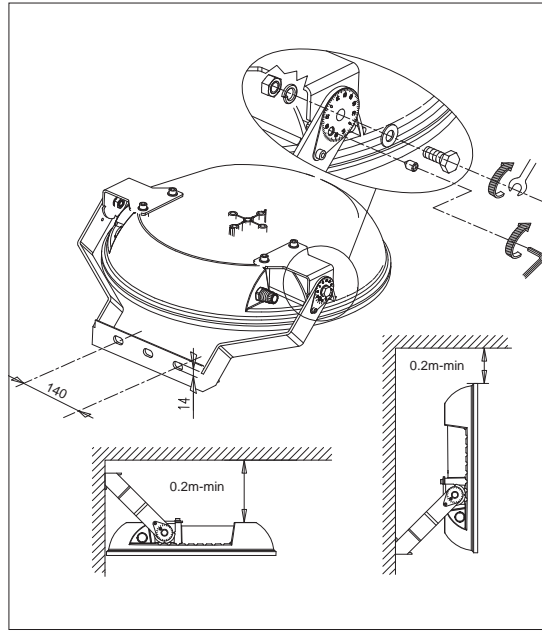

**Code:** 2020.001

Staffa orientabile per montaggio a parete  
*Shaped bracket for wall mounting*



**Code:** CA1000.018

Catena per installazione a sospensione - Lunghezza 1m  
*Chain for suspension installation - Length 1m*

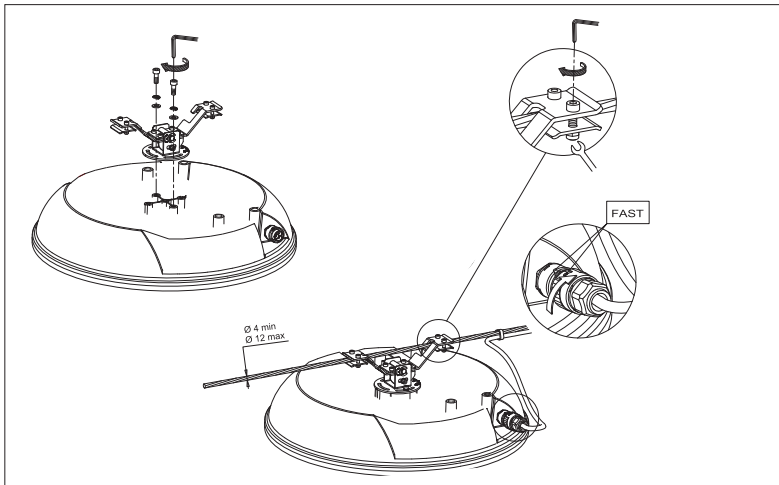

**Code:** 703960.0101 - Staffa a tesata - *Suspension mounting*



**Cod:** 703952.NEW

Attacco palo per 1 o 2 proiettori, Ø 60/76mm  
*Pole attachment for either 1 or 2 floodlights, size Ø 60/76mm*

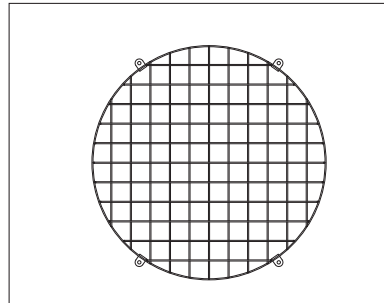

**Cod:** 800017.0101 - **LED Minizeus**  
Griglia di protezione - *Protection grid*

**Cod:** 800016.0101 - **LED Zeus**  
Griglia di protezione - *Protection grid*

**Code:** RO0640/N

### PROTEZIONE ALLE SOVRATENSIONI (di serie in LED Zeus) SURGE PROTECTOR (of serie in LED zeus)

In un impianto elettrico standard un apparecchio a LED può essere sottoposto a sbalzi di tensione e disturbi esterni dovuti a fattori quali carichi discontinui sulla linea, guasti sulle linee a monte o a valle e, soprattutto, scariche atmosferiche (negli impianti esterni). Nei nostri proiettori, dove l'elettronica è fondamentale, la resistenza alle sovratensioni è sinonimo di affidabilità e corretta funzionalità.

*In a standard electrical system an LED luminaire can be subjected to voltage fluctuations and external disturbances due to factors such as discontinuous loads on the line, faults on the lines upstream or downstream and, especially, atmospheric discharges (in External Plants). In our projectors, where electronics is very important, the surge resistance is synonymous with reliability and proper functionality.*



Dispositivo di protezione conforme alla Norma EN 61547 contro i fenomeni impulsivi atto a proteggere il modulo LED e il relativo alimentatore: classe II fino a 10kV

*Protection device in compliance with the EN 61547 standard to counteract the impulsive phenomena designed to protect the LED module and the relative power supply: class II protection up to 10kV*

### Sovratensioni

Le sovratensioni sono un rapido innalzamento della differenza di potenziale tra le diverse polarità (Fase o Neutro) e la Terra, in alcuni casi sono talmente elevate da superare la soglia di isolamento dei componenti elettronici causandone così il danneggiamento. Esistono anche casi di sovratensioni di entità inferiore, le quali non provocano un immediato guasto dei moduli LED o driver privi di protezione, ma se nel tempo si verificano ripetutamente possono provocare il deterioramento dei LED, di conseguenza, una durata ridotta. Nel caso di sovratensioni di elevata entità, come la caduta dei fulmini, provocano invece un guasto immediato dei moduli LED o dei driver. Le sovratensioni, di fatto, provocano degli impulsi di energia con correnti elevate sia nel driver che nei moduli LED.

### Overvoltages

*Overvoltages are a rapid rise in the potential difference between the different polarities (Phase or Neutral) and the Earth, in some cases they are so high as to exceed the isolation threshold of the electronic components, thus causing damage. There are also cases of minor overvoltages, which do not cause an immediate failure of the unprotected LED modules or drivers, but if they occur repeatedly over time they can cause deterioration of the LEDs, consequently a reduced life span. In the event of high voltage surges, such as lightning strikes, they cause immediate failure of the LED modules or drivers. The overvoltages, in fact, cause energy pulses with high currents in both the driver and the LED modules.*



**A richiesta:** verniciatura resistente a 2.000 ore di esposizione alla nebbia salina in accordo alla norma ISO 9227 certificato da Ente esterno.

*On request: painting resistant to 2,000 hours of exposure to salt spray in accordance with ISO 9227 certified by an external body.*



# LED Minizeus - LED Zeus

Soluzioni NON incluse per aumentare il risparmio energetico - NOT included solutions to increase energy saving

## Sensor - Sensor

### Luce solo all'occorrenza - Light only when needed

Rilevatore di movimento a microonde con crepuscolare per impostazione soglia minima Lux ambiente di intervento e con livello di stand-by impostabile (10-20-30%) con driver dimmerabili [0-10V]; questa tecnologia emette onde elettromagnetiche ad alta frequenza (5,8GHz) e riceve il loro eco, in questo modo è in grado di riconoscere una qualsiasi variazione data da un oggetto non rilevato nella precedente analisi e verrà dato il comando di ON. La trasmissione ad alta frequenza è <10mW e risulta essere 100 volte inferiore alle emissioni di un comune telefono cellulare o di un forno a microonde che emettono mediamente 1000mW.

Microwave motion detector with twilight with adjustable stand-by level for setting Lux threshold for the intervention environment and with settable stand-by level (10-20-30%) with dimmable [0-10V] driver; this technology it emits electromagnetic waves at a high frequency (5.8GHz) and receives their echoes. In this way, it can recognise any variation given by an object not detected in the previous analysis and the ON command will be given. High frequency transmission is <10mW and is 100 times lower than the emissions of a common mobile phone or a microwave oven emitting an average of 1000mW.



Rilevatore di movimento a microonde con crepuscolare e stand-by regolabile, aggiungere Y dopo il codice

+ Euro 80,00 al prezzo di listino

Microwave motion detector with crepuscular and dimmable stand-by, add Y after the code + Euro 80.00 to the list price

Esempio applicativo  
Installazione su corpo illuminante

Application example  
Installation on lighting body



Specifiche tecniche - Technical specification	
Tensione di rete - Power supply	220-240Vac - 50/60Hz
Potenza - Power	1000W - 500VA
Frequenza - Frequency	5,8GHz
Angolo di rilevamento - Detection angle	360°
Velocità di rilevamento movimento Motion detection speed	0,5-3m/s
Altezza di installazione - Assembly height	1÷15 m
Consumo energetico - Energy consumption	< 0,9W
Grado IP - IP degree	IP65
Tecnologia - Technology	Microonde - Microwave
Temperatura di funzionamento sensore Sensor operating temperature	-35...50°C
Tempo di spegnimento - Switch-off time	10 sec ÷ 30 min
Sensibilità lux - Lux sensitivity	5÷200 lux 24h
Sensibilità - Sensitivity	12m (regolabile - reglable)
Trasmissione di segnale - Signal transmission	< 10mW
Stand-by dimming level	0%, 10%, 20%, 30%

LED Minizeus + Sensor  
Dimensioni (mm) - Dimensions (mm)

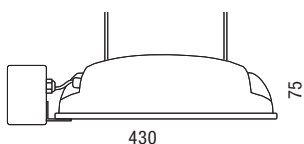

LED Zeus + Sensor  
Dimensioni (mm) - Dimensions (mm)

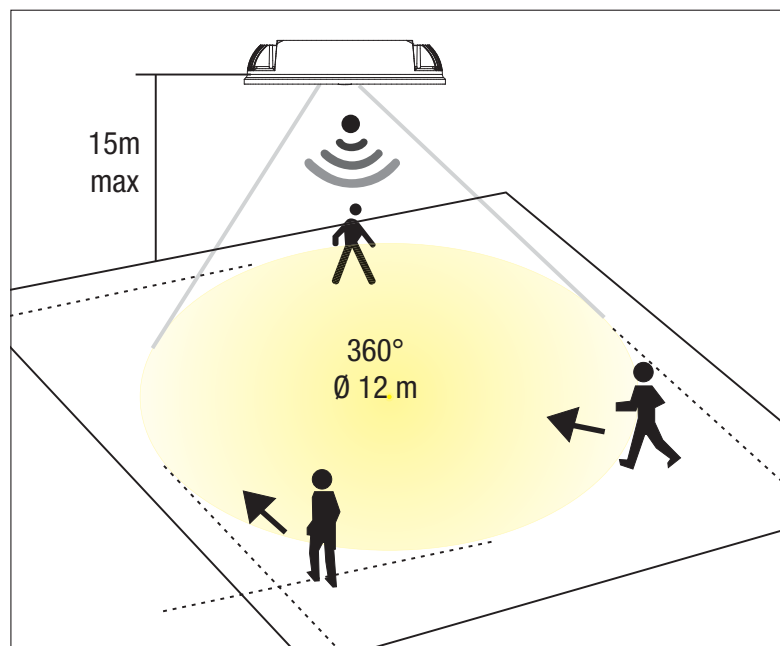

### Trasmittitore incluso - Included transmitter

Carico acceso Load on

Carico spento Load off

Lampeggio di test del carico Lamp will be auto test to be on and off

Funzionamento automatico impostazione di fabbrica = 24h tempo 10'' - distanza 100% Automatic operation factory setting = 24h time 10'' - distance 100%

Ampiezza di rilevamento Detection width

Livello di luminosità in stand-by Stand-by dimming level  
OFF = 0%  
M1 = 10%  
M2 = 20%  
M3 = 30%

Sensibilità Lux Lux sensitivity

Tempo di spegnimento Hold time

# LED Minizeus - LED Zeus

Soluzioni NON incluse per aumentare il risparmio energetico - NOT included solutions to increase energy saving

## DYNA Control

**Fig. 1 - Esempio applicativo 2 steps - Application example 2 steps**

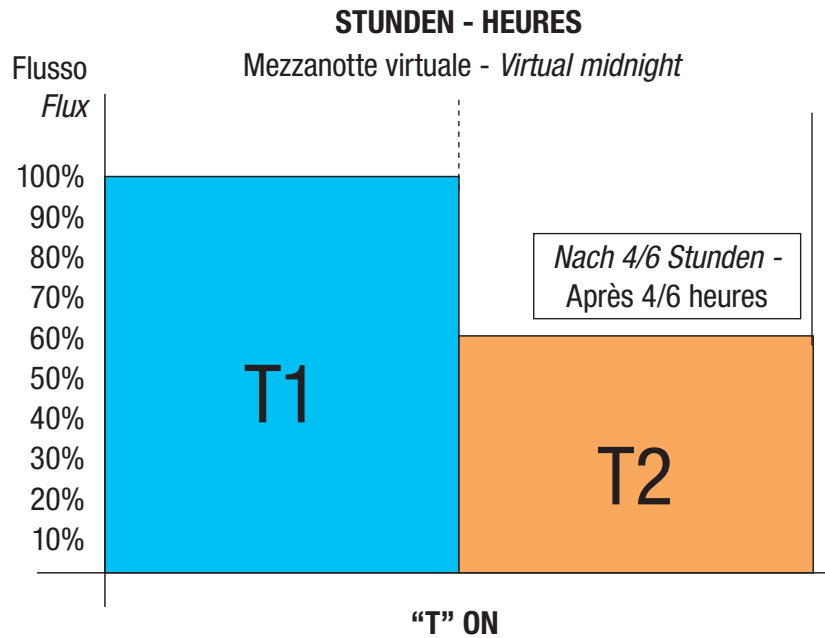

**T1 = 100% Flusso luminoso**

**T1 = 100% Luminous flux**

**T2 = 70% Flusso luminoso**

**T2 = 70% Luminous flux**

Minimo tempo di accensione per funzionamento automatico 4 ore (3 giorni).  
 Accensioni di 1 ora ignorate.  
 Accensioni da 1 a 4 ore oppure superiori alle 23 ore resettano il sistema.

*The minimum ignition time for automatic operation is 4 hours (three days).  
 Ignitions 1 hour ignored.  
 Switching from 1 to 4 hours or higher with 23 hours reset the system.*

DYNA CONTROL è un sistema di controllo del flusso luminoso delle lampade che si basa sul calcolo della mezzanotte virtuale. Il sistema entra in funzione alla prima accensione calcolando per 3 giorni i tempi di accensione. Il quarto giorno il sistema, in modo autonomo, calcola la mezzanotte virtuale eseguendo una regolazione del flusso e regolando la lampada come indicato sullo schema di Fig. 1. La riduzione del flusso luminoso avviene senza la necessità di alcun cavo di connessione aggiuntivo o dispositivo di comando esterno, questo sistema consente di ottenere un notevole risparmio energetico.

N.B. su richiesta è possibile eseguire la modifica delle impostazioni di fabbrica della mezzanotte virtuale adattandole alle specifiche del cliente.

*DYNA CONTROL is a control system for the luminous flux of the lamps which is based on virtual midnight calculation. The system starts running when turned on for the first time, calculating the start-up times for 3 days. On the fourth day, the system automatically calculates the virtual midnight by performing a flux adjustment and adjusting the lamp as indicated on the diagram of Fig. 1. The reduction of the luminous flux occurs without the need for any additional connection cable or external control device. This system can achieve considerable energy saving.*

*N.B. the factory settings of the virtual midnight can be modified on request, adjusting them to the customer's specifications.*

+ Euro 50,00 da listino - Aggiungere DC dopo il codice

+ Euro 50,00 to the price list - Add DC after the code

### Su richiesta - On demand

LED Minizeus e LED Zeus a richiesta possono essere forniti in versione EMERGENZA On request, LED Minizeus and LED Zeus are can be supplied in an EMERGENCY version	
	
Batteria inclusa. Tempo di ricarica: 24h Included battery. Charging time: 24h	
Autonomy	LED EMERGENCY KIT
2h	6W SA-SE 2h - IP67
On demand	LED EMERGENCY KIT
3h	3W SA-SE 3h - IP67



Aggiungere 2E (2h) o 3E (3h) dopo il codice - + Euro 120,00 al prezzo di listino  
 Add 2E (2h) or 3E (3h) after the code - + Euro 120.00 to the list price

# LED Milano Logistica



La certificazione fotometrica dei nostri apparecchi viene sempre effettuata da un istituto esterno. Efficienza luminosa e "lm Output" sono quindi il risultato di tale istituto.

*The photometric certification of our appliances is always carried out by an external institute. Luminous efficiency and "lm Output" are therefore the result of this institute.*

A richiesta - On demand

1-10Vdc

Pag. VI

DALI 2

Pag. VI

DMX

Pag. VI

Wireless

Pag. VI

Il LED Milano Logistica è un proiettore adatto per l'illuminazione di stabilimenti di produzione, magazzini e depositi. La particolare forma permette di avere diverse potenze e fasci luminosi stretti e precisi, specifici per l'installazione a notevole altezza. La qualità delle parti elettroniche, del corpo lampada e dei materiali assicurano sicurezza in fase di esercizio nelle condizioni ambientali più critiche.

**Installazione:** sospensione (con ganci), parete/plafone (con staffa)

**Corpo e telaio:** alluminio pressofuso

**Staffa di fissaggio:** in acciaio zincato a caldo, con goniometro graduato per un corretto puntamento del fascio luminoso

**Verniciatura:** speciale eseguita a polvere, resistente agli agenti atmosferici e alla corrosione e alle nebbie. Colore Grigio RAL 9007.

**Ottica:** in policarbonato metallizzato

**Schermo:** vetro temperato ultra-white resistente agli shock termici e agli urti h 4mm

**Sorgente:** LED

Mantenimento del flusso luminoso minimo al 70%: 80.000h (L70B20) per l'80% dei LED.

**Temperatura di colore:** 4000K (CRI 80). A richiesta 5700K (CRI 90);

**Driver LED multipotenza:**

Certificato 

Fattore di potenza:  $\geq 0,9$

Protezione: 5/10kV

**Norme di riferimento**

EN60598-1; EN60598-2-1; EN62471; EN62031

EN60598-2-5; EN61547

*The Milano Logistica LED is a projector suitable for lighting production plants, warehouses and warehouses.*

*Different light intensities and narrow and precise light beams are possible due to the special design of the lamp body and light source, specifically for installation at a considerable height. The quality of the electronic parts, lamp body and materials ensure operating safety under even the most critical of environmental conditions.*

*Installation: suspension (with hooks), wall ceiling (with bracket)*

*Housing and frame: die-cast aluminium*

*Fitting stirrup: in hot galvanised steel with graduated goniometer for correct pointing of the light beam*

*Painting: special powder coating, resistant to atmospheric agents, corrosion and mists. Grey RAL 9007.*

*Optic: in metallized polycarbonate*

*Screen: ultra-white tempered glass resistant to thermal shocks and impacts h 4mm*

*Source: LED*

*Maintenance of 70% minimum luminous flux: 80,000h (L70B20) for 80% of the LEDs.*

*Color temperature: 4000K (CRI 80). On demand 5700K (CRI 90);*

*Driver LED:*

*Certified *

*Power factor:  $\geq 0,9$*

*Surge protection: 5/10kV*

*Standard reference*

*EN60598-1; EN60598-2-1; EN62471; EN62031*

*EN60598-2-5; EN61547*



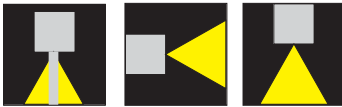
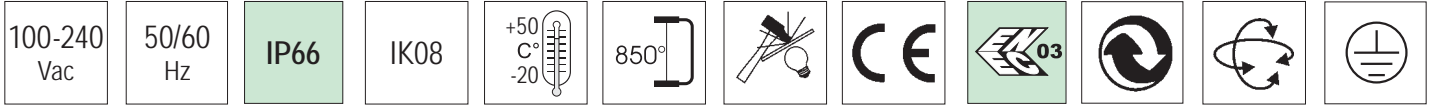

# LED Milano Logistica

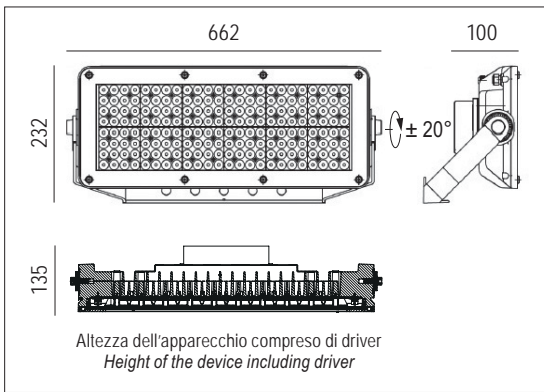

colour	W	angle	K	CRI	nominal Im tc = 25°C	lm output	lm/W	pcs	Kg	CELL
G	200	50°	4000	80	32.800	29.000	145	1	11,00	MIL20050-4K
G	200	90°	4000	80	32.800	29.000	145	1	11,00	MIL20090-4K
G	200	ELLIP	4000	80	32.800	29.000	145	1	11,00	MIL200EL-4K
G	250	50°	4000	80	40.900	36.250	145	1	11,00	MIL25050-4K
G	250	90°	4000	80	40.900	36.250	145	1	11,00	MIL25090-4K
G	250	ELLIP	4000	80	40.900	36.250	145	1	11,00	MIL250EL-4K
G	300	50°	4000	80	49.100	43.500	145	1	11,00	MIL30050-4K
G	300	90°	4000	80	49.100	43.500	145	1	11,00	MIL30090-4K
G	300	ELLIP	4000	80	49.100	43.500	145	1	11,00	MIL300EL-4K
G	400	50°	4000	80	65.500	58.000	145	1	11,00	MIL40050-4K
G	400	90°	4000	80	65.500	58.000	145	1	11,00	MIL40090-4K
G	400	ELLIP	4000	80	65.500	58.000	145	1	11,00	MIL400EL-4K

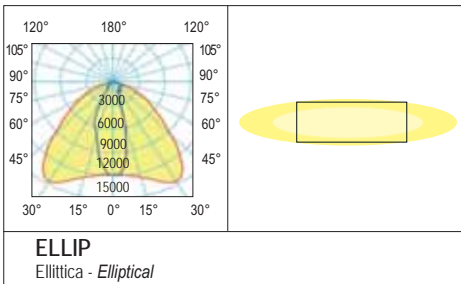
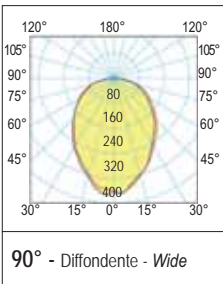
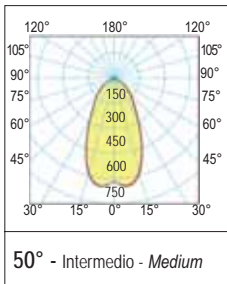

A richiesta accessorio STAFFA DI FISSAGGIO  
On demand FIXING BRACKET accessory  
Cod. STRIMISPORT



Esempio applicativo Installazione su corpo illuminante con sensore a richiesta  
Application example Installation on lighting body with sensor on demand

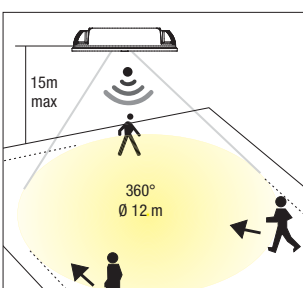
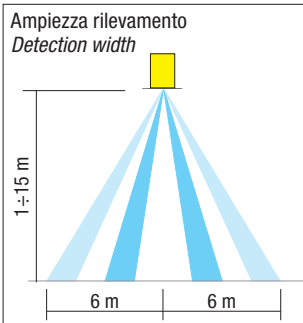

LED Milano Logistica a richiesta può essere fornito in versione EMERGENZA 2h 6W o 3h 3W  
On request, LED Milano Logistica are can be supplied in an EMERGENCY version



Floodlight

# BASIC series LED Punto Highbay 250W



LED Punto Highbay è un apparecchio progettato per fornire un'illuminazione uniforme e senza interruzioni per applicazioni industriali ed è una soluzione ideale per altezze di montaggio più elevate, applicazioni ad alta temperatura e industria pesante speciale.

**Colore** nero RAL 9004.

**Ottica:** diffondente

**Schermo:** in policarbonato 4mm resistente agli shock termici e agli urti.

**Sorgente LED SMD:** incorporato con temperatura di colore 4000K; altre temperature di colore a richiesta.

**Driver:** incorporato fattore di potenza:  $\geq 0,9$

*Punto Highbay Led is a luminaire designed to provide undisrupted and uniform lighting for industrial application and is an ideal solution for higher mounting heights, high temperature applications and special heavy-duty industry.*

*RAL 9004 black color.*

**Optic:** diffused

**Shield:** in polycarbonate with 4mm thickness resistant to thermal shocks and collisions

**Light source SMD LED:** included with color temperature 4000K; other color temperatures available on demand.

**Driver:** included Power factor:  $\geq 0,9$

## Installation - Installation

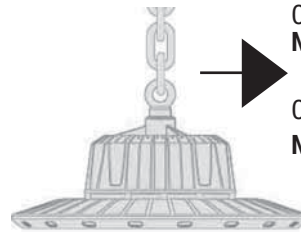

Catena per applicazione in sospensione  
**NON INCLUSO**

Chain for suspension application  
**NOT INCLUDED**

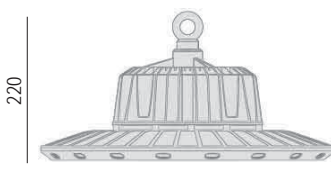
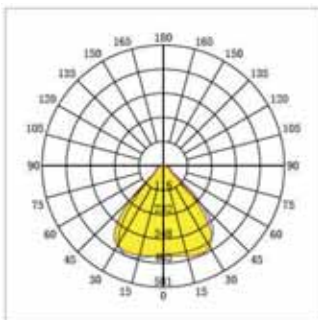

Ø 455

LED Punto 250

Color	Diffusor	Code
■ Nero Black	□ Vetro Glass	RL2251052

Sorgente Source	<b>LED</b>
Potenza Power	250W
Temperatura di colore Color temperature	4000K
Flusso luminoso Lighting output	27.500Lm
Peso (kg) Weight (kg)	4,20

CE IK08 IP65 CRI>80 CELL

100-264V 50/60Hz





# BASIC series LED Punto Highbay 3 CCT ( 3000 / 4000 / 6000K ) 3 Power ( 100 / 150 / 200W )



LED Punto Highbay è un apparecchio progettato per fornire un'illuminazione uniforme per applicazioni industriali ed è una soluzione ideale per altezze di montaggio più elevate, applicazioni ad alta temperatura e industria pesante speciale.

**Colore** nero RAL 9004.

**Ottica:** diffusore 100°

**Schermo:** in policarbonato 4mm resistente agli shock termici e agli urti.

**Sorgente LED SMD:** incorporato con temperatura di colore 3000/4000/6000K; altre temperature di colore a richiesta.

**Driver:** incorporato fattore di potenza:  $\geq 0,9$

*Punto Highbay Led is a luminaire designed to provide uniform lighting for industrial application and is an ideal solution for higher mounting heights, high temperature applications and special heavy-duty industry.*

*RAL 9004 black color.*

*Optic: diffused 100°*

*Shield: in polycarbonate with 4mm thickness resistant to thermal shocks and collisions*

*Light source SMD LED: included with color temperature 3000/4000/6000K; other color temperatures available on demand.*

*Driver: included Power factor:  $\geq 0,9$*

## Installation - Installation

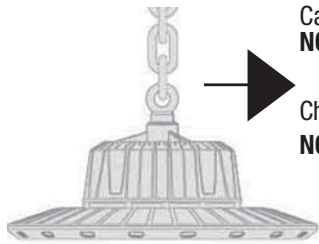

Catena per applicazione in sospensione  
**NON INCLUSO**

Chain for suspension application  
**NOT INCLUDED**



Dissipatore di calore in alluminio pressofuso per un'eccellente dissipazione del calore e resistenza alla corrosione.

Die-cast aluminum heat sink for excellent heat dissipation and strength to corrosion.

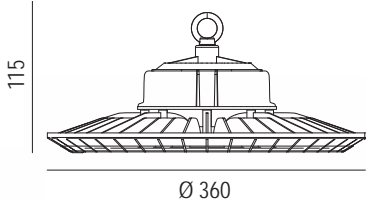
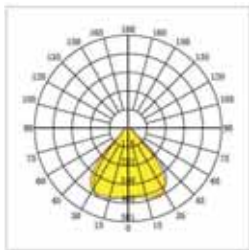

**150 lm/W**



Floodlight

LED Punto 6

Color	Diffusor	Code
Nero Black	Policarbonato Polycarbonate	RL225106X1

Sorgente Source Taratura di fabbrica  
Factory setting

Potenza Power 100W-150W- **200W**

Temperatura di colore Color temperature 3000K-4000K- **6000K**

Flusso luminoso Lighting output 150Lm/W

Peso (kg) Weight (kg) 3,00

CRI>80 CELL

100-264V 50/60Hz





# LED Zeus ATEX 2-22



**Installazione:** a parete o a sospensione.

**Corpo e telaio:** in alluminio pressofuso UNI EN 1706 verniciato con polvere termoindurente poliesteri.

**Staffa di fissaggio:** in acciaio, verniciata con polvere termoindurente poliesteri, con goniometro graduato per un corretto puntamento del fascio luminoso.

**PG:** pressacavo in metallo M20x1,5 ATEX PA66 (cavo Ø 10÷14mm<sup>2</sup>)

**Verniciatura:** di tipo poliesteri eseguita a polvere, resistente agli agenti atmosferici, alla corrosione e alla nebbia salina. Grigio RAL 9007

**Ottica:** semi concentrante realizzata in PMMA resistente ai raggi UV

**Schermo:** vetro temprato di spessore 4mm resistente agli shock termici e agli urti.

**Protezione alle sovratensioni inclusa:**

Modo differenziale 6kV (L-N)

Modo comune 10kV (L-GND, N-GND, L&N-GND)

**Sorgente:** LED LUMILEDS 5050

Mantenimento del flusso luminoso minimo al 90% - 100.000h (L90B10) per il 90% dei LED.

**Temperatura di colore:** 4000K;

**Driver:** incorporato  0-10V.

Fattore di potenza ≥0,95.

*Installation: on the wall or suspended.*

*Housing and frame: made by UNI EN 1706 Die-cast aluminum, coated with polyester thermoset powder.*

*Fixing bracket: made by stainless steel, coated with polyester thermoset powder, with graduated goniometer to allow the correct orientation of light beam*

*Metal cable glands: screwed M20x1,5 (Cable Ø 10÷14mm<sup>2</sup>)*

*Coating: coated with powdered polyester, resistant to atmospheric agents and corrosion and guaranteed in saline mist. RAL Grey 9007*

*Optic: semi-clumping made in PMMA resistant to UV radiation*

*Shield: tempered glass with 4mm thickness resistant to thermal shocks and collisions.*

**Protection against overvoltages included:**

Differential mode 6kV (L-N)

Standard mode 10kV (L - GND, N-GND, L&N-GND)

**Light source:** LED LUMILEDS 5050

Maintenance of minimum luminous flux to 90% - 100.000h (L90B10) for 90% of LED.

**Color temperature:** 4000K;

**Driver:** included  0-10V.

Power factor ≥0,95

**IEP** | ENERGY PETROLEUM INSTITUTE

**IEP ATEX**

(1) **Type Examination Certificate**

(2) Equipment or Protective Systems Intended for use in Potentially Explosive Atmospheres  
Directive 2014/34/EU

(3) Type Examination Certificate Number: IEP 20 ATEX 0848

(4) Equipment: LED Zeus Type , Led Lighting Fixtures

(5) Firm Name: RELCO S.R.L.

(6) Firm Address: Via delle Azalee 6/A - 20090 Buccinasco (MI) - ITALY

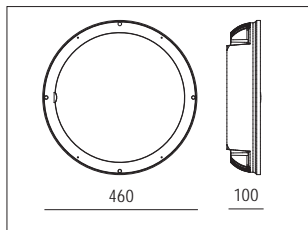
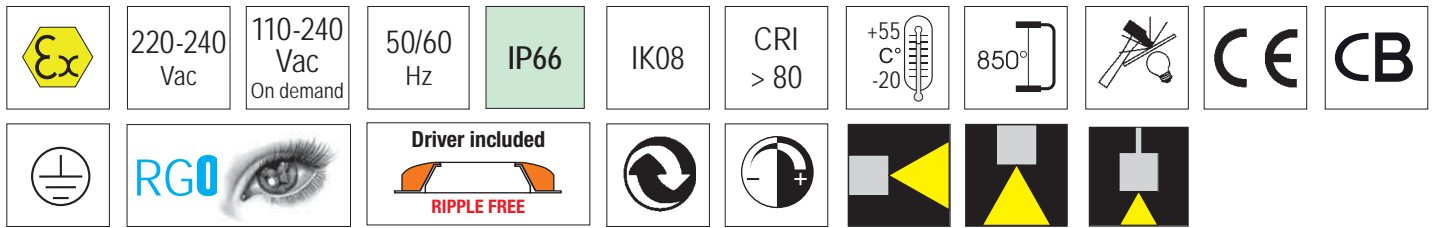

	colour	W	angle	K	nominal lm tc = 25°C	lm output	lm/W	pcs	Kg	CELL
1-10Vdc	G	175	50°	4000	23.100	21.000	120	1	9,70	334087.185ATX
1-10Vdc	G	210	50°	4000	27.700	25.200	120	1	9,70	334087.210ATX

**A richiesta:** potenze, ottiche e colorazione del LED diverse da quelle standard  
*On demand: powers, optics and LED colours different from the standard ones*

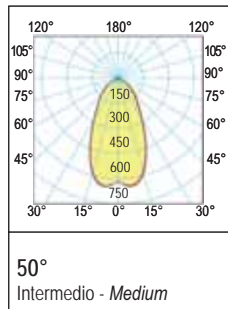

Protezione contro le atmosfere esplosive <i>Protection against explosive atmospheres</i>	CE Ex II 3G Ex nR IIC T4 Ge
Zona pericolosa ammessa <i>Hazardous area allowed</i>	Zona 2 - Zone 2 Zona 22 - Zone 22
Normative di riferimento <i>Standard references</i>	EN60079-0 / EN60079-15 EN60079-31 / EN60079-28
<b>Use:</b> the light fitting is suitable for the environment with a danger of explosion of gas, dust and combustible fumes. The light fittings meet the requirements of Government Decree 116/2016 Coll. and European Community Directive N°. 2014/34/EU.	

LED Zeus ATEX viene fornito completo di gancio per applicazione a sospensione

LED Zeus ATEX comes complete with hook for application to suspension

**Accessori non inclusi - Not Included accessories**

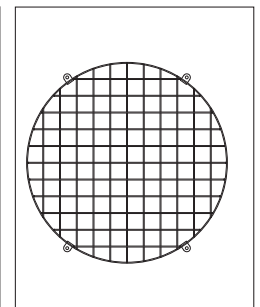
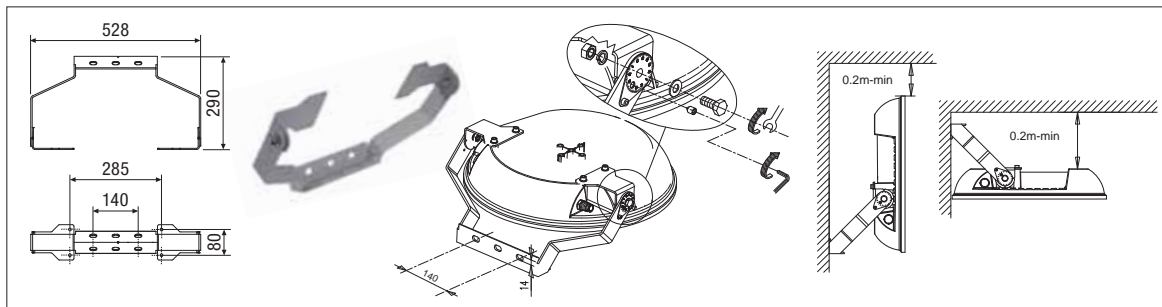

**Code:** 703959.0101  
 Staffa sagomata orientabile per montaggio a parete più goniometro per puntamento proiettore  
*Shaped adjustable bracket for wall mounting complete with protractor pointing to the projector*

**Code:** 800016.0101  
 Griglia di protezione  
*Protection grid*

# LED AGP Evolution ATEX 2-22



Proiettore da incasso, parete e plafone particolarmente adatto per magazzini, garage, stazioni di servizio e luoghi con atmosfera potenzialmente esplosiva. Completo di alimentatore elettronico.

**Installazione:** ad incasso, parete e plafone

**Corpo e telaio:** in alluminio pressofuso

**Verniciatura:** di tipo poliestere eseguita a polvere, resistente agli agenti atmosferici e alla corrosione. Colore Bianco RAL 9003.

**PG:** pressacavo in metallo M16 (cavo Ø 4÷8mm<sup>2</sup>)

**Ottica:** diffondente realizzata in PMMA resistente ai raggi UV

**Sorgente:** LED **PHILIPS** lumileds  
Mantenimento del flusso luminoso minimo al 90% - 100.000h (L90B10) per il 90% dei LED

**Driver:** incorporato   
Fattore di potenza ≥ 0,95.

*Recessed flood light particularly suitable for warehouses, garages, service stations and places in general with potentially explosive atmosphere. Complete with electronic ballast.*

*Installation: recessed, wall and ceiling*

*Body and frame: die cast aluminum*

*Coating: coated with powdered polyester, resistant to atmospheric agents and corrosion. White colour RAL 9003*

*PG: M16 metal cable gland (cable 4÷8mm<sup>2</sup>)*

*Optic: wide made of UV-resistant PMMA*

*Light source: LED **PHILIPS** lumileds  
Maintenance of minimum luminous flux to 90% - 100.000h (L90B10) for 90% of LED.*









*Driver:  certified.*

*Power factor ≥ 0,95.*

**Use:** the light fitting is suitable for the environment with a danger of explosion of gas, dust and combustible fumes. The light fittings meet the requirements of Government Decree 116/2016 Coll. and European Community Directive N°. 2014/34/EU.

Floodlight



	100-277 Vac	50/60 Hz	IP66	IK10	CRI > 70	+55 C -20	850°
	CE	CB		Driver included  RIPPLE FREE			
RGO 							

colour	W	angle	K	nominal lm tc = 25°C	lm output	lm/W	pcs	Kg	CELL
B	100	120°	4000	18.400	16.000	160	1	4,00	RL04-100
B	150	120°	4000	26.700	23.250	155	1	4,00	RL04-150

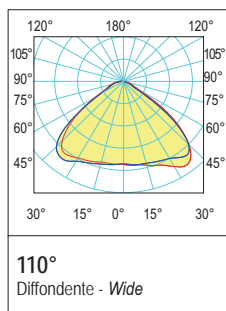

Protezione contro le atmosfere esplosive <i>Protection against explosive atmospheres</i>	CE  II 2G Ex ib IIC T6
Zona pericolosa ammessa <i>Hazardous area allowed</i>	Zona 2 - Zone 2 Zona 22 - Zone 22
Normative di riferimento <i>Standard references</i>	EN 60079-0:2012/A11:2013 EN 60079-11:2012 EN60079-31:2014

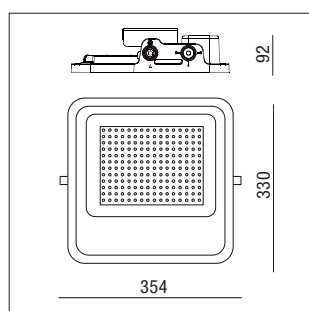



# LED AGP Evolution ATEX 2-22

## Accessori non inclusi - *Not included accessories*



Cod. RL04/PL  
Accessorio per installazione a plafone  
*Accessory for ceiling installation*



Cod. RL04/R  
Accessorio per installazione a incasso  
*Accessory for recessed installation*  
Dimensioni - *Dimensions*: 400x400mm



Cod. RL04/S  
Accessorio staffa  
*Bracket accessory*



Cod. 703952.NEW  
Attacco palo per 1 o 2 proiettori, Ø60/76mm  
*Pole attachment for either 1 or 2 floodlights, size Ø 60/76mm.*

### Application example

Accessory for recessed application



Accessory for ceiling application



Bracket accessory



# LED Allegra Plus

145 Lm/W

Waterproof luminaires

La certificazione fotometrica dei nostri apparecchi viene sempre effettuata da un istituto esterno. Efficienza luminosa e "lm Output" sono quindi il risultato di tale istituto.

*The photometric certification of our appliances is always carried out by an external institute. Luminous efficiency and "lm Output" are therefore the result of this institute.*

A richiesta - On demand



Sensor DIM  
1-10V

Sensor DIM  
DALI

Apparecchi di illuminazione a LED per applicazioni a luce diffusa da interno e da esterno. Le elevate prestazioni illuminotecniche consentono a questi apparecchi di illuminazione di poter essere collocati in molteplici campi applicativi quali ad esempio, aree comuni, negozi, magazzini anche dove sia richiesto un elevato indice di protezione alle polveri (6), all'acqua (5) ed agli urti (8).

**Installazione:** a soffitto o a sospensione

**Corpo:** in policarbonato grigio infrangibile stabilizzato ai raggi UV. Colore Grigio RAL 7038

**Ganci e viteria:** in acciaio Inox

**Cavo:** privo di alogenuri

**Diffusore:** in policarbonato semi-opale di ottima qualità, autoestinguento V2 stabilizzato ai raggi UV

**Conforme alla norma:** EN62471: 2008, sicurezza fotobiologica delle lampade e sistemi di lampade.

**Driver:** incluso nel sistema > 50.000 h

Fattore di potenza  $\geq 0,95$ .

**Sorgente:** LED LG. Mantenimento del flusso luminoso minimo al 80% - 80.000h (L80B20).

**Temperatura di colore:** 4000K. Altre temperature di colore a richiesta (2200K - 2700K - 3000K - 5000K - Consegna: 60 giorni).

**A richiesta:** con rilevatore di movimento a microonde con crepuscolare - Cod. BC360A-D02 (Vedi Pag. 67)

**Norme di riferimento**

EN60598-1; EN60598-2-1; EN62471

EN62031; EN60598-2-5; EN61547

*LED lighting fixtures for indoor and outdoor diffused light applications. Thanks to their high lighting performance, these fixtures can be used in a number of applications, such as common areas, shops and warehouses but also where high protection from dust (6), water (5) and shocks (8) is required.*

**Installation:** ceiling or suspended

**Housing:** high quality semi-opal polycarbonate, self-extinguishing V2 stabilized against UV rays. Grey RAL 7038

**Hooks and screw:** in stainless steel

**Cable:** halogen free

**Diffuser:** made by semi-opal polycarbonate

**Complying to standard:** EN62471: 2008, photobiological safety of lamps and lamp systems

**Driver:** included included in the system > 50.000 h

Power factor  $\geq 0,95$ .

**Source:** LED LG. Maintenance of minimum luminous flux to 80% - 80.000h (L80B20).

**Color temperature:** 4000K. (other color temperatures on demand (2200K - 2700K - 3000K - 5000K - Delivery time: 60 days).

**On demand:** with microwave motion detector with crepuscular - Cod. BC360A-D02 (see Pag. 67)

**Standard references**

EN60598-1; EN60598-2-1; EN62471

EN62031; EN60598-2-5; EN61547

220-240 Vac	50/60 Hz	110 Vac On demand	IP66	IK09 Body	IK10 Diffusor	CRI > 80	+40 C -20	CE	ELC 17	
850°		TECEE	RG0	LOW FLICKER	Driver included MULTIPOWER					

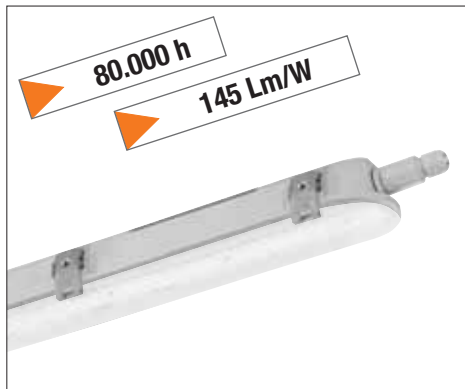

colour	W	L (mm)	Optic	K	lm output	lm/W	pcs	Kg	CELL
G	20	650	110°	4000	2900	145	1	1,70	32003/H
G	24	1220	110°	4000	3480	145	1	1,70	32001/H
G	36	1220	110°	4000	5220	145	1	1,70	32002/H
G	45	1220	110°	4000	6520	145	1	1,70	32030/H
G	54	1560	110°	4000	7800	145	1	2,40	32031/H
G	65	1560	110°	4000	9400	145	1	2,40	32031/60/H

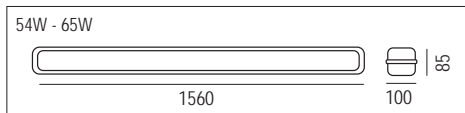
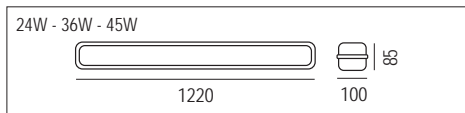
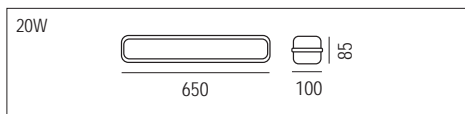

AUTOTEST									
colour	W	L (mm)	Optic	K	lm output	lm/W	pcs	Kg	CELL-E
G	20	650	110°	4000	2900	145	1	1,90	32003/H/EMER
G	24	1220	110°	4000	3480	145	1	1,90	32001/H/EMER
G	36	1220	110°	4000	5220	145	1	1,90	32002/H/EMER
G	45	1220	110°	4000	6520	145	1	2,20	32030/H/EMER
G	54	1560	110°	4000	7800	145	1	2,60	32031/H/EMER
G	65	1560	110°	4000	9400	145	1	2,60	32031/60/H/EM

**AUTOESTINGUENZA:** LED Allegra Plus è realizzata in un materiale plastico in classe V2. Con questo materiale il corpo lampada si spegnerà entro 25°.

**FILO INCANDESCENTE:** LED Allegra Plus è resistente alla prova del filo incandescente per 850°C.

**SELF-EXTINGUISHING:** LED Allegra Plus is made of a plastic material in class V2. With this material the specimen will turn off within 25°.

**INCANDESCENT WIRE:** LED Allegra Plus is resistant to the glow wire test for 850 °C.

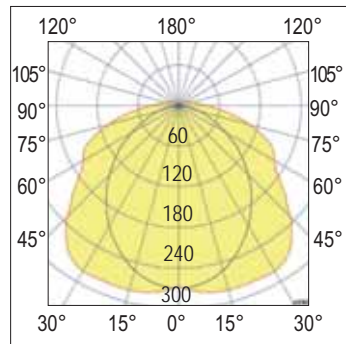

110°  
Diffondente - Wide

DALI 2									
colour	W	L (mm)	Optic	K	lm output	lm/W	pcs	Kg	CELL
G	24	1220	110°	4000	3480	145	1	1,70	32001/H/DALI
G	36	1220	110°	4000	5220	145	1	1,70	32002/H/DALI
G	45	1220	110°	4000	6520	145	1	1,70	32030/H/DALI
G	54	1560	110°	4000	7800	145	1	2,40	32031/H/DALI
G	65	1560	110°	4000	9400	145	1	2,40	32031/60/H/DA

AUTOTEST DALI 2									
colour	W	L (mm)	Optic	K	lm output	lm/W	pcs	Kg	CELL-E
G	24	1220	110°	4000	3480	145	1	1,90	32001/H/EM/DA
G	45	1220	110°	4000	6520	145	1	2,20	32030/H/EM/DA
G	54	1560	110°	4000	7800	145	1	2,60	32031/H/EM/DA



## **Apparecchi in emergenza - Emergency wired luminaires**

### Apparecchi di illuminazione cablati in emergenza

Relco nella politica di offrire un servizio migliore alla clientela, ha deciso di utilizzare nei suoi apparecchi di illuminazione dotati di emergenza, solo **INVERTER PER EMERGENZA CON AUTOTEST**.

Le norme europee EN 1838, EN 60598-2-22, relative ai sistemi di illuminazione di emergenza, impongono che periodicamente, siano effettuati dei test per verificare sia il funzionamento sia l'efficienza (durata in emergenza) degli apparecchi di illuminazione che svolgono anche la funzione di illuminazione di emergenza. Questo costringe i manutentori dell'impianto ad interrompere la linea di alimentazione ed effettuare test con cadenza settimanale (test funzionale), e con cadenza trimestrale o annuale (test di autonomia).

Con i nostri kit di emergenza con autotest (conformi alla normativa europea EN 62034) queste prove vengono svolte automaticamente con cadenza programmabile in fase di installazione. Inoltre il nostro inverter analizza i tempi di normale accensione e spegnimento dell'apparecchio ed effettua (qualora possibile) i test nelle ore di assenza delle persone.

Eventuali anomalie sono segnalate tramite un indicatore (led) rosso verde.

A partire dal colore della segnalazione è possibile stabilire in maniera univoca gli eventuali problemi di funzionamento come evidenziato nella tabella seguente.

### Emergency wired luminaires

Relco in its policy of offering a better service to customers, has decided to use only **EMERGENCY INVERTER WITH SELF-TEST** in its luminaires equipped with emergency.







The European standards EN 1838, EN 60598-2-22, relating to emergency lighting systems, require that tests be periodically carried out to verify both the functioning and the efficiency (duration in emergency) of the lighting fixtures which also the emergency lighting function. This forces the system maintainers to interrupt the power supply line and carry out tests on a weekly basis (functional test), and on a quarterly or annual basis (autonomy test).

With our emergency kits with self-test (complying with European standard EN 62034) these tests are carried out automatically with a programmable cadence during installation.

Furthermore, our inverter analyzes the normal switching on and off times of the appliance and carries out (where possible) the tests in the hours when people are absent.

Any anomalies are signaled by a red-green indicator (led). Starting from the color of the signal, it is possible to unequivocally establish any functioning problems as shown in the following table.



	Colore LED - LED indication	Stato - Status
	Verde fisso - Permanent Green	Batteria carica o in carica - Battery charge or charging
	Verde lampeggiante - Flashing Green	Funzione TEST avviata - TEST in progress
	Verde lampeggiante lento (1s ON - 1s OFF) Slow flashing green (1s ON - 1s OFF)	TEST di autonomia avviato Autonomy TEST in progress
	Rosso fisso - Permanent Red	Lampada guasta - Lamp failure
	Rosso lampeggio veloce (0,1s ON - 0,1s OFF) Fast flashing Red (0,1s ON - 0,1s OFF)	Guasto circuito di ricarica - Charging failure
	Lampeggio Rosso lento (1s ON - 1s OFF) Slow flashing Red (1s ON - 1s OFF)	Batteria guasta - Battery failure
	Verde e Rosso OFF - Green and Red OFF	Emergenza ON - Emergency ON

### A richiesta - On demand



### Emergency

Con cablaggio in emergenza ad **alimentazione centralizzata**.

Apparecchio permanente, con alimentatore funzionante AC/DC, alimentato da un sistema di emergenza centralizzato, cioè non incorporato nell'apparecchio.

With centralized emergency wiring. Permanent device, with AC / DC power supply, **powered by a centralized** emergency system, i.e. not incorporated into the device



Connettore rapido incluso in tutti i modelli  
Included fast connection in all models

### LED Allegra Plus - Connettore 2 poli - 2 pole connections



### LED Allegra Plus - Connettore 4 poli - 4 pole connections



1-10Vdc



DALI 2



  
Emergency

# LED Allegra Plus

## Accessori inclusi - Included accessories



**!** Staffa di fissaggio a parete/plafone in acciaio inox. Tasselli e viti non compresi. Per l'installazione a parete o soffitto utilizzare tasselli e viti adeguati alla superficie su cui andrà ancorata.  
*Wall/ceiling fixing bracket made by stainless steel. Plug and screws are not included. For ceiling or wall installation use plug and screws adapted to surface upon which it will be anchored.*

Kit per montaggio a parete/plafone e sospensione  
*Wall/Ceiling and suspension mounting kit*

## Accessori NON inclusi - NOT included accessories

Code: 3001.580

Griglia di protezione LED Allegra Plus 54W - LED Allegra Plus 65W  
*Protection grille LED Allegra Plus 54W - LED Allegra Plus 65W*

## Luce solo all'occorrenza - Light only when needed

A richiesta - On demand

1-10Vdc



**Rilevatore di MOVIMENTO a microonde con crepuscolare** per impostazione soglia Lux ambiente di intervento, questa tecnologia consente di "nascondere" il rilevatore anche all'interno di corpi lampada infatti esso emette onde elettromagnetiche ad alta frequenza (5,8GHz) e riceve il loro eco, in questo modo è in grado di riconoscere una qualsiasi variazione data da un oggetto non rilevato nella precedente analisi e verrà dato il comando di ON. La trasmissione ad alta frequenza è <10mW e risulta essere 100 volte inferiore alle emissioni di un comune telefono cellulare o di un forno a microonde che emettono mediamente 1000mW.  
**Installazione: da incorporare**

*Microwave MOTION detector with crepuscular. This technology allows the detector to be "hidden" within lamp bodies, in fact it emits electromagnetic waves at a high frequency (5.8GHz) and receives their echoes. In this way, it can recognise any variation given by an object not detected in the previous analysis and the ON command will be given. High frequency transmission is <10mW and is 100 times lower than the emissions of a common mobile phone or a microwave oven emitting an average of 1000mW.*  
**Installation: built-in use**



Versione **con sensore di rilevamento a distanza Radar Control ON/OFF**. Aggiungere Y dopo il codice - es. 32030/HY. Più Euro 30,00 dal prezzo di listino  
*Version with remote detection sensor Radar control ON/OFF. Add Y after the code - ex. 32030/HY). + 30,00 Euros from the list price*

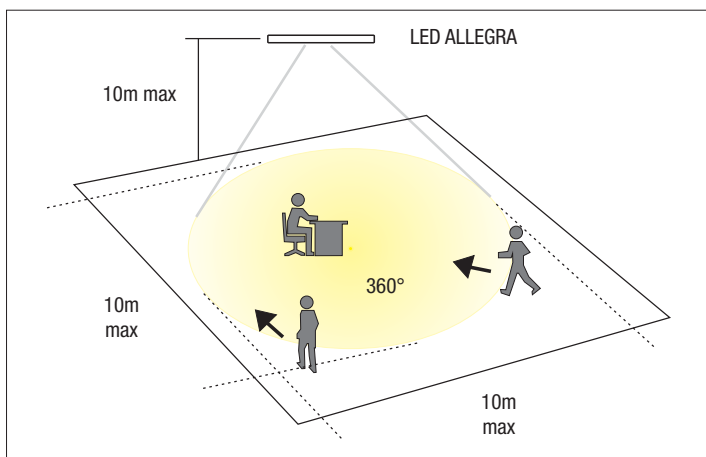

# LED Allegra TOP *Predisposta per cablaggio in fila continua* *Prepared for loop in - loop out*

155 Lm/W



Waterproof luminaires

Apparecchi di illuminazione a LED per applicazioni a luce diffusa da interno e da esterno. Le elevate prestazioni illuminotecniche consentono a questi apparecchi di illuminazione di poter essere collocati in molteplici campi applicativi quali ad esempio, aree comuni, negozi, magazzini anche dove sia richiesto un elevato indice di protezione alle polveri (6), all'acqua (5) ed agli urti (8).

**Installazione:** a soffitto o a sospensione

**Corpo:** Colore Grigio RAL 7035

**Cavo:** privo di alogenuri

**Diffusore:** PC semi-opale, anti-UV

**Conforme alla norma:** EN62471: 2008, sicurezza fotobiologica delle lampade e sistemi di lampade.

**Driver:** incluso nel sistema > 50.000 h  
Fattore di potenza  $\geq 0,95$ .

**Sorgente:** LED LUMILEDS. Mantenimento del flusso luminoso minimo al 80% - 80.000h (L80B20).

**Temperatura di colore:** 4000K (a richiesta 3000K o 5000K).

**A richiesta:** con rilevatore di movimento a microonde con crepuscolare.

**Norme di riferimento**

EN60598-1; EN60598-2-1; EN62471  
EN62031; EN60598-2-5; EN61547

*LED lighting fixtures for indoor and outdoor diffused light applications. Thanks to their high lighting performance, these fixtures can be used in a number of applications, such as common areas, shops and warehouses but also where high protection from dust (6), water (5) and shocks (8) is required.*

*Installation:* ceiling or suspended

*Housing:* in Grey, RAL7035

*Cable:* halogen free

*Diffuser:* It is semi-opal PC, Anti-UV

*Driver:* included included in the system > 50.000 h  
Power factor  $\geq 0,95$ .

*Source:* LED LUMILEDS. Maintenance of minimum luminous flux to 80% - 80.000h (L80B20).

*Color temperature:* 4000K (on demand 3000K or 5000K).

*On demand:* with microwave motion detector with crepuscular

**Standard references**

EN60598-1; EN60598-2-1; EN62471  
EN62031; EN60598-2-5; EN61547

## A richiesta - on demande



### Emergency

Con cablaggio di emergenza con alimentazione centralizzata. Apparecchio a installazione fissa con alimentazione AC/DC, alimentato da un sistema di emergenza centralizzato, ovvero non integrato nell'apparecchio.

*With emergency wiring with central power supply. Permanently installed luminaire with AC/DC power supply, fed by a central emergency system, i.e. not built into the luminaire.*



220-240 Vac    50/60 Hz    110 Vac On demand    IP65    IK08    CRI > 80    +40°C -20°C    CE       850°      

RG0    LOW FLICKER

Driver included **MULTIPOWER**       Pending



colour	W Max	L (mm)	Optic	K	lm output	lm/W	pcs	Kg	CELL
G	20	555	110°	4000	3100	155	1	1,70	32003/TOP
G	21	1155	110°	4000	3250	155	1	1,70	32001/TOP
G	36	1155	110°	4000	5580	155	1	1,70	32002/TOP
G	45	1155	110°	4000	6.970	155	1	1,70	32030/TOP
G	34	1455	110°	4000	5270	155	1	1,70	32034/TOP
G	48	1455	110°	4000	7440	155	1	1,70	32031/TOP
G	54	1455	110°	4000	8370	155	1	1,70	32054/TOP
G	70	1455	110°	4000	10.850	155	1	1,70	32070/TOP

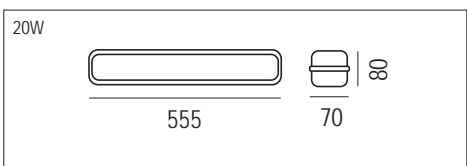

**AUTOTEST**

colour	W Max	L (mm)	Optic	K	lm output	lm/W	pcs	Kg	CELL-E
G	20	555	110°	4000	3100	155	1	1,90	32003/TOPEM
G	21	1155	110°	4000	3250	155	1	1,90	32001/TOPEM
G	36	1155	110°	4000	5580	155	1	1,90	32002/TOPEM
G	45	1155	110°	4000	6.970	155	1	1,70	32030/TOPEM
G	34	1455	110°	4000	5270	155	1	1,90	32034/TOPEM
G	48	1455	110°	4000	7440	155	1	1,90	32031/TOPEM
G	54	1455	110°	4000	8370	155	1	1,70	32054/TOPEM
G	70	1455	110°	4000	10.850	155	1	1,70	32070/TOPEM

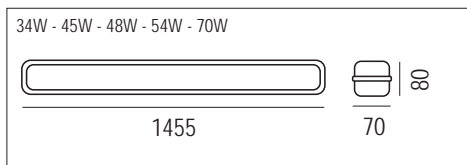
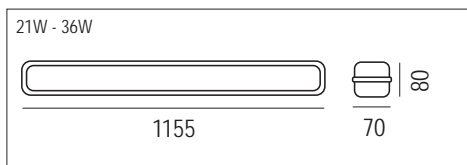

**DALI 2**

colour	W Max	L (mm)	Optic	K	lm output	lm/W	pcs	Kg	CELL
G	20	555	110°	4000	3100	155	1	1,90	32003/TOP/DA
G	21	1155	110°	4000	3250	155	1	1,70	32001/TOP/DA
G	36	1155	110°	4000	5580	155	1	1,70	32002/TOP/DA
G	45	1155	110°	4000	6.970	155	1	1,70	32030/TOP/DA
G	34	1455	110°	4000	5270	155	1	1,70	32034/TOP/DA
G	48	1455	110°	4000	7440	155	1	1,70	32031/TOP/DA
G	54	1455	110°	4000	8370	155	1	1,70	32054/TOP/DA
G	70	1455	110°	4000	10.850	155	1	1,70	32070/TOP/DA



**AUTOESTINGUENZA:** LED Allegra Top è realizzata in un materiale plastico in classe V2. Con questo materiale il corpo lampada si spegnerà entro 25°.

**FILO INCANDESCENTE:** LED Allegra Top è resistente alla prova del filo incandescente per 850°C.

**SELF-EXTINGUISHING:** LED Allegra Top is made of a plastic material in class V2. With this material the specimen will turn off within 25°.

**INCANDESCENT WIRE:** LED Allegra Top is resistant to the glow wire test for 850 ° C.

**AUTOTEST DALI 2**

colour	W Max	L (mm)	Optic	K	lm output	Lm/W	pcs	Kg	CELL-E
G	20	555	110°	4000	3100	155	1	1,90	32003/TOPEMDA
G	21	1155	110°	4000	3250	155	1	1,90	32001/TOPEMDA
G	36	1155	110°	4000	5580	155	1	1,90	32002/TOPEMDA
G	45	1155	110°	4000	6.970	155	1	1,70	32030/TOPEMDA
G	34	1455	110°	4000	5270	155	1	1,90	32034/TOPEMDA
G	48	1455	110°	4000	7440	155	1	1,90	32031/TOPEMDA
G	54	1455	110°	4000	8370	155	1	1,70	32054/TOPEMDA
G	70	1455	110°	4000	10.850	155	1	1,70	32070/TOPEMDA

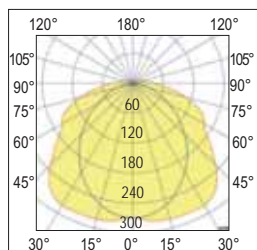

110°  
Diffondente - Wide

# LED Allegra TOP

Predisposto per cablaggio in fila continua  
*Prepared for continuous line wiring*



Accessori inclusi - *Included accessories*



La staffa in acciaio inox fornita di serie consente l'installazione facile e sicura dell'apparecchio a soffitto o parete. Il gancio a molla consente il collegamento rapido a qualsiasi sistema di sospensione a catena.

*The stainless steel bracket supplied as standard allows easy and safe installation of the luminaire on the ceiling or wall. The spring hook allows for quick connection to any chain suspension system.*

## Assemblaggio in fila continua

Il dispositivo è dotato di speciali "dentini" di allineamento che permettono il perfetto allineamento delle strutture, il collegamento al morsetto rapido è invisibile alla vista, rendendoli discreti.

## Continuous row assembly

*The device is equipped with special alignment "teeth" which allow perfect alignment of the frameworks, the connection to the quick clamp is invisible to the eye, making them discreet.*

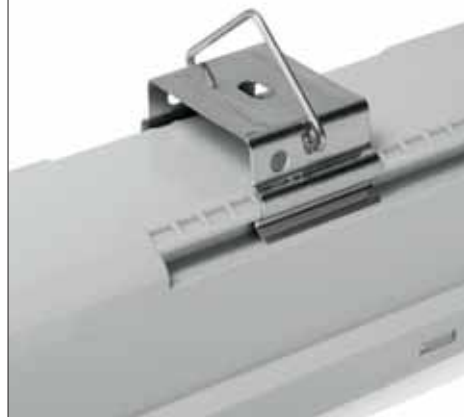

## Morsetto rimovibile

Particolare del terminale estraibile con innesto rapido dei cavi di collegamento, la chiusura avviene a pressione con apposite clips poste ai lati della chiusura con pressacavo.

## Removable clamp

*Detail of the removable terminal with quick connection of cables for connection, closure is done by pressure with special clips placed on the sides of the closure with cable gland.*

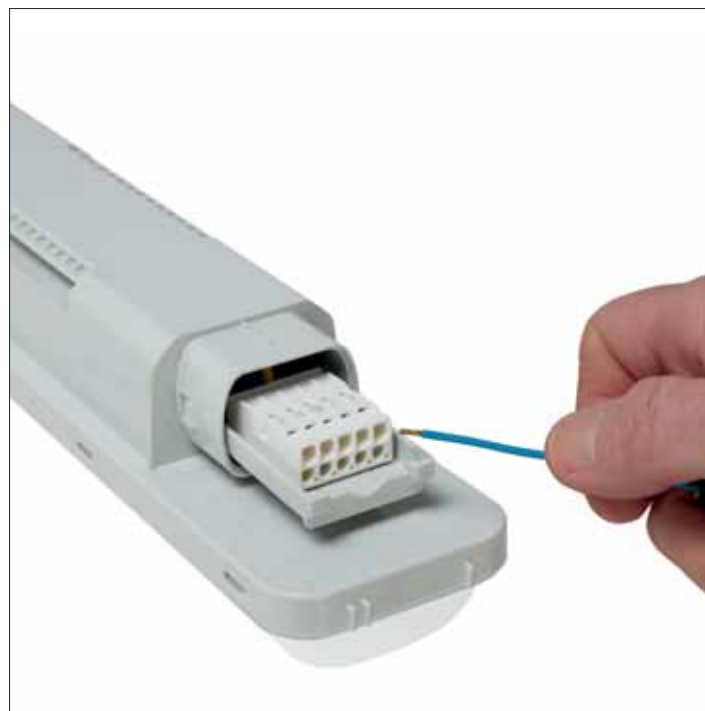

# Apparecchi in emergenza - Emergency wired luminaires

## Apparecchi di illuminazione cablati in emergenza

Relco nella politica di offrire un servizio migliore alla clientela, ha deciso di utilizzare nei sui apparecchi di illuminazione dotati di emergenza, solo INVERTER PER EMERGENZA CON AUTOTEST.

Le norme europee EN 1838, EN 60598-2-22, relative ai sistemi di illuminazione di emergenza, impongono che periodicamente, siano effettuati dei test per verificare sia il funzionamento sia l'efficienza (durata in emergenza) degli apparecchi di illuminazione che svolgono anche la funzione di illuminazione di emergenza. Questo costringe i manutentori dell'impianto ad interrompere la linea di alimentazione ed effettuare test con cadenza settimanale (test funzionale), e con cadenza trimestrale o annuale (test di autonomia). Con i nostri kit di emergenza con autotest (conformi alla normativa europea EN 62034) queste prove vengono svolte automaticamente con cadenza programmabile in fase di installazione. Inoltre il nostro inverter analizza i tempi di normale accensione e spegnimento dell'apparecchio ed effettua (qualora possibile) i test nelle ore di assenza delle persone. Eventuali anomalie sono segnalate tramite un indicatore (led) rosso verde. A partire dal colore della segnalazione è possibile stabilire in maniera univoca gli eventuali problemi di funzionamento come evidenziato nella tabella seguente.

## Emergency wired luminaires

Relco in its policy of offering a better service to customers, has decided to use only EMERGENCY INVERTER WITH SELF-TEST in its luminaires equipped with emergency.

The European standards EN 1838, EN 60598-2-22, relating to emergency lighting systems, require that tests be periodically carried out to verify both the functioning and the efficiency (duration in emergency) of the lighting fixtures which also the emergency lighting function. This forces the system maintainers to interrupt the power supply line and carry out tests on a weekly basis (functional test), and on a quarterly or annual basis (autonomy test). With our emergency kits with self-test (complying with European standard EN 62034) these tests are carried out automatically with a programmable cadence during installation. Furthermore, our inverter analyzes the normal switching on and off times of the appliance and carries out (where possible) the tests in the hours when people are absent. Any anomalies are signaled by a red-green indicator (led). Starting from the color of the signal, it is possible to unequivocally establish any functioning problems as shown in the following table.



Colore LED - LED indication	Stato - Status
Verde fisso - Permanent Green	Batteria carica o in carica - Battery charge or charging
Verde lampeggiante - Flashing Green	Funzione TEST avviata - TEST in progress
Verde lampeggiante lento (1s ON - 1s OFF) Slow flashing green (1s ON - 1s OFF)	TEST di autonomia avviato Autonomy TEST in progress
Rosso fisso - Permanent Red	Lampada guasta - Lamp failure
Rosso lampeggio veloce (0,1s ON - 0,1s OFF) Fast flashing Red (0,1s ON - 0,1s OFF)	Guasto circuito di ricarica - Charging failure
Lampeggio Rosso lento (1s ON - 1s OFF) Slow flashing Red (1s ON - 1s OFF)	Batteria guasta - Battery failure
Verde e Rosso OFF - Green and Red OFF	Emergenza ON - Emergency ON

## Luce solo all'occorrenza - Light only when needed

### A richiesta - On demand

1-10Vdc DALI 2



Rilevatore di MOVIMENTO a microonde con sensore crepuscolare per regolare la soglia Lux dell'ambiente di intervento, questa tecnologia permette di "nascondere" il rilevatore anche all'interno dei corpi lampada, infatti emette onde elettromagnetiche ad alta frequenza (5,8 GHz) e ne riceve l'eco, in questo modo è in grado di riconoscere l'eventuale variazione data da un oggetto non rilevato durante l'analisi precedente e verrà dato il comando di ON. La trasmissione ad alta frequenza è <10 mW ed è 100 volte inferiore alle emissioni di un telefono cellulare o di un forno a microonde convenzionale che emettono in media 1000 mW.

**Installazione: da incorporare**

Microwave MOTION detector with twilight sensor to adjust the Lux threshold of the intervention environment, this technology allows the detector to be "hidden" even inside the lamp bodies, in fact it emits electromagnetic waves at high frequency (5.8 GHz) and receives their echo, in this way it is able to recognize any variation given by an object not detected during the previous analysis and the ON command will be given. The high frequency transmission is <10 mW and is 100 times lower than the emissions from a cell phone or a conventional microwave oven which emit an average of 1000 mW.

**Installation: to be incorporated**



Versione con sensore di rilevamento a distanza Radar Control ON/OFF. Aggiungere "Y" dopo il codice es. 32000/F-EY. Più Euro 30,00 dal prezzo di listino

Version with remote detection sensor Radar control ON/OFF. Add "Y" after the code - ex. 32000/F-EY. + 30,00 Euros from the list price

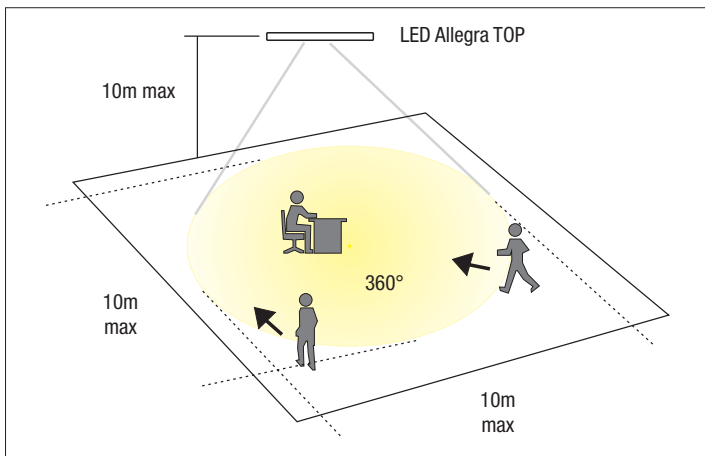



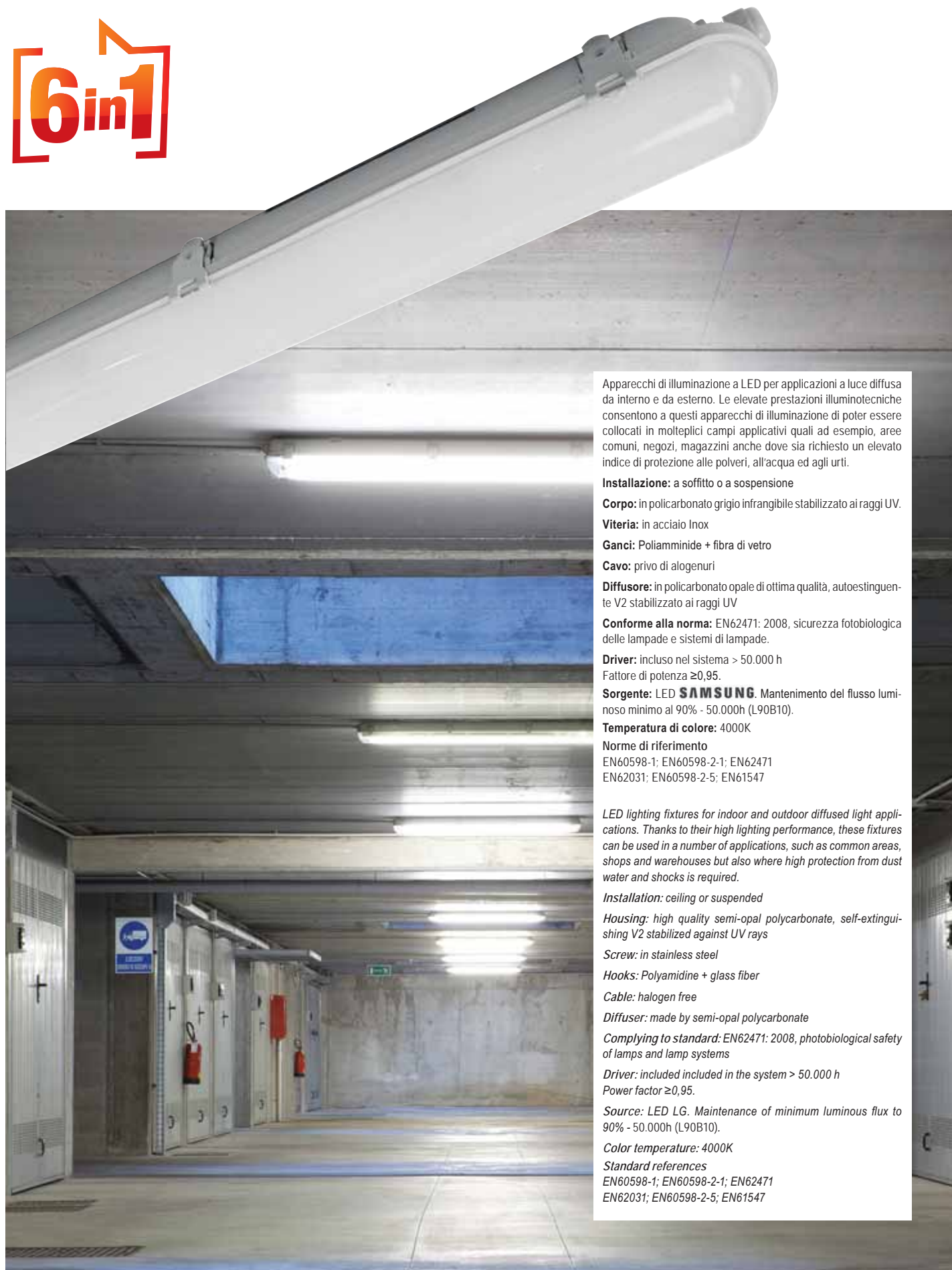

Waterproof luminaires

Apparecchi di illuminazione a LED per applicazioni a luce diffusa da interno e da esterno. Le elevate prestazioni illuminotecniche consentono a questi apparecchi di illuminazione di poter essere collocati in molteplici campi applicativi quali ad esempio, aree comuni, negozi, magazzini anche dove sia richiesto un elevato indice di protezione alle polveri, all'acqua ed agli urti.

**Installazione:** a soffitto o a sospensione

**Corpo:** in policarbonato grigio infrangibile stabilizzato ai raggi UV.

**Viteria:** in acciaio Inox

**Ganci:** Poliammide + fibra di vetro

**Cavo:** privo di alogenuri

**Diffusore:** in policarbonato opale di ottima qualità, autoestinguente V2 stabilizzato ai raggi UV

**Conforme alla norma:** EN62471: 2008, sicurezza fotobiologica delle lampade e sistemi di lampade.

**Driver:** incluso nel sistema > 50.000 h  
Fattore di potenza  $\geq 0,95$ .

**Sorgente:** LED **SAMSUNG**. Mantenimento del flusso luminoso minimo al 90% - 50.000h (L90B10).

**Temperatura di colore:** 4000K

**Norme di riferimento**

EN60598-1; EN60598-2-1; EN62471  
EN62031; EN60598-2-5; EN61547

*LED lighting fixtures for indoor and outdoor diffused light applications. Thanks to their high lighting performance, these fixtures can be used in a number of applications, such as common areas, shops and warehouses but also where high protection from dust water and shocks is required.*

*Installation: ceiling or suspended*

*Housing: high quality semi-opal polycarbonate, self-extinguishing V2 stabilized against UV rays*

*Screw: in stainless steel*

*Hooks: Polyamide + glass fiber*

*Cable: halogen free*

*Diffuser: made by semi-opal polycarbonate*

*Complying to standard: EN62471: 2008, photobiological safety of lamps and lamp systems*

*Driver: included included in the system > 50.000 h  
Power factor  $\geq 0,95$ .*

*Source: LED LG. Maintenance of minimum luminous flux to 90% - 50.000h (L90B10).*

*Color temperature: 4000K*

*Standard references*

EN60598-1; EN60598-2-1; EN62471  
EN62031; EN60598-2-5; EN61547

220-240 Vac    50/60 Hz    IP66    IK08    CRI > 80    +45°C / -25°C    CE       850°       RGO

**Driver included**

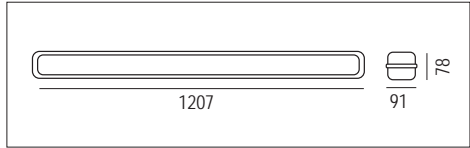
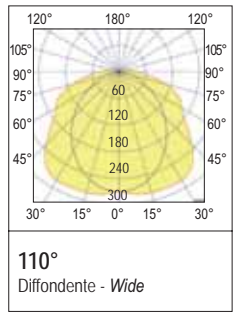
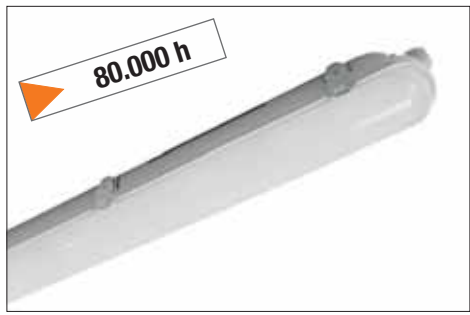

colour	W	Optic	K			lm output	lm/W	pcs	Kg	CELL
	max 42	110°	4000			max 5.460	130	1	2,50	32030/C
	max 42	110°	3000	4000	6000	max 5.460	130	1	2,50	32030/C-3CCT

**3CCT SWITCHABLE**

**AUTOTEST**

colour	W	Optic	K			lm output	lm/W	pcs	Kg	CELL-E
	max 42	110°	4000			max 5.460	130	1	2,50	32030/C/EM
	max 42	110°	3000	4000	6000	max 5.460	130	1	2,50	32030/C/3/EM

**3CCT SWITCHABLE**

**Flusso/potenza regolabili manualmente su 4 step - Flux / power manually adjustable on 4 steps**

**LED Driver multipotenza incluso**  
*LED Driver multipower included*

I mA	W
200	18
250	24
300	36
350	42
Taratura di fabbrica Factory setting	



Per una corretta gestione dell'impianto di illuminazione, bisogna sempre tenere conto sia della necessità di illuminamento realizzato tramite calcolo illuminotecnico, che il rispetto dei consumi energetici.

I nostri modelli LED Allegra Basic permettono di ottenere questo risultato poiché sono dotati di Driver multipower: questi particolari Driver consentono di impostare la corrente in uscita tramite dip-switch, fornendo, di conseguenza, la corretta potenza di lampada in base all'esigenza desiderata, permettendo quindi sia il risparmio energetico che il rispetto del flusso luminoso determinato in fase di progetto.

*For proper management of the lighting system, it is always necessary to take into account both the need for lighting achieved through lighting engineering calculations, and respect for energy consumption.*

*Our Allegra Basic LED models allow to obtain this result as they are equipped with multipower Driver; these particular drivers allow you to set the output current via dip-switches, thus providing the correct lamp power based on the desired need, thus allowing both energy savings and respect for the luminous flux determined in the design phase.*

**Accessori inclusi - Included accessories**



Staffa di fissaggio a parete/plafone in acciaio inox. Tasselli e viti non compresi. Per l'installazione a parete o soffitto utilizzare tasselli e viti adeguati alla superficie su cui andrà ancorata.

*Wall/ceiling fixing bracket made by stainless steel. Plug and screws are not included. For ceiling or wall installation use plug and screws adapted to surface upon which it will be anchored.*

Waterproof luminaires

# LED Pupilla sensor DIM

80.000 h

165 Lm/W

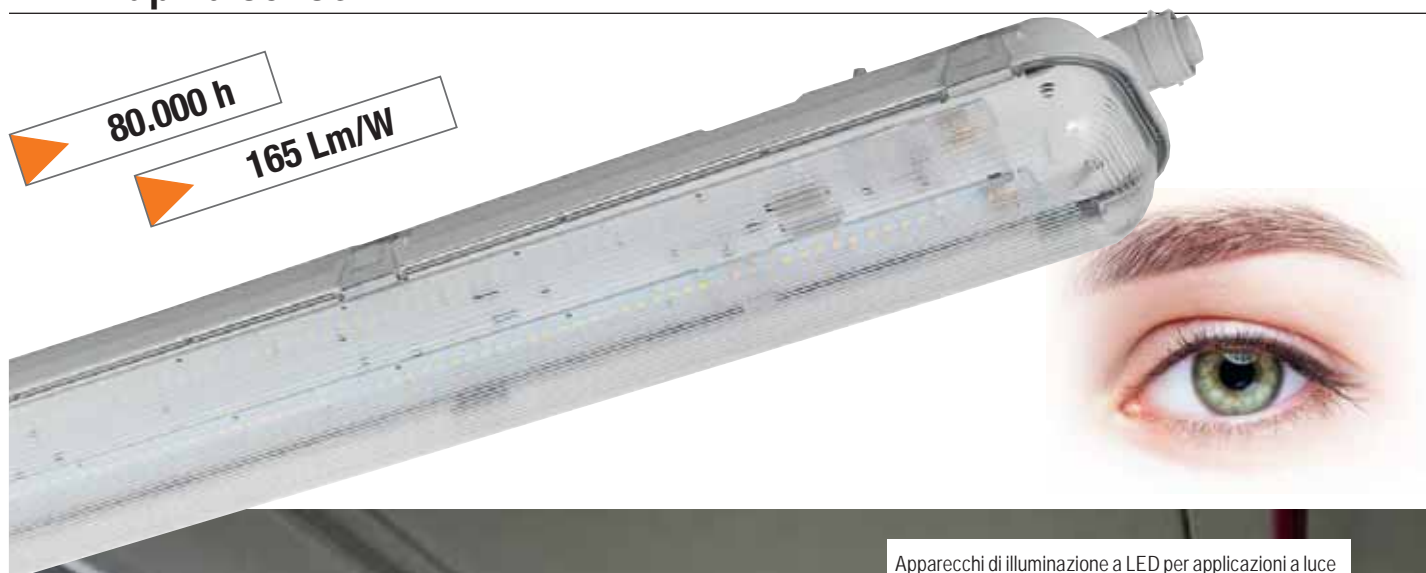

Apparecchi di illuminazione a LED per applicazioni a luce diffusa da interno e da esterno con sensore di presenza/ luminosità integrato nella lampada

**Installazione:** a soffitto o a sospensione

**Corpo:** base in plastica rinforzata con vetro **GRP (Glass Reinforced Plastic)**.

**Ganci e viteria:** in acciaio Inox

**Diffusore:** in policarbonato trasparente (a richiesta in policarbonato semi opale - aggiungere O dopo il codice). Finitura liscia.

**Conforme alla norma:** EN62471: 2008, sicurezza fotobiologica delle lampade e sistemi di lampade.

**Driver:** incluso nel sistema   
Fattore di potenza  $\geq 0,90$ .

**Sorgente:** LED LUMILEDS 3528

Mantenimento del flusso luminoso minimo al 80% - 80.000h (L80B20).

**Temperatura di colore:** 4000K. Altre temperature di colore a richiesta (3000K - 5000K - Consegna: 60 giorni).

**Norme di riferimento**

EN60598-1; EN60598-2-1; EN62471  
EN62031; EN60598-2-5; EN61547

*LED lighting fixtures for indoor and outdoor diffused light applications with presence / light sensor integrated in the lamp*

*Housing: in plastic reinforced with GRP glass (Glass Reinforced Plastic).*

*Installation: ceiling or suspended*

*Hooks and screws: in stainless steel*

*Diffuser: made by transparent polycarbonate (in semi-opal polycarbonate on demand - add O after the code). Smooth finish.*

*Complying to standard: EN62471: 2008, photobiological safety of lamps and lamp systems*

*Driver: included included in the system > 50.000 h  
Power factor  $\geq 0,90$ .*

*Source: LED LUMILEDS 3528*

*Maintenance of minimum luminous flux to 80% - 80.000h (L80B20).*

*Color temperature: 4000K. Other color temperatures on demand (3000K - 5000K - Delivery time: 60 days).*

*On demand: with microwave motion detector with crepuscular*

*Standard references*

EN60598-1; EN60598-2-1; EN62471  
EN62031; EN60598-2-5; EN61547

La certificazione fotometrica dei nostri apparecchi viene sempre effettuata da un istituto esterno. Efficienza luminosa e "lm Output" sono quindi il risultato di tale istituto.

*The photometric certification of our appliances is always carried out by an external institute. Luminous efficiency and "lm Output" are therefore the result of this institute.*

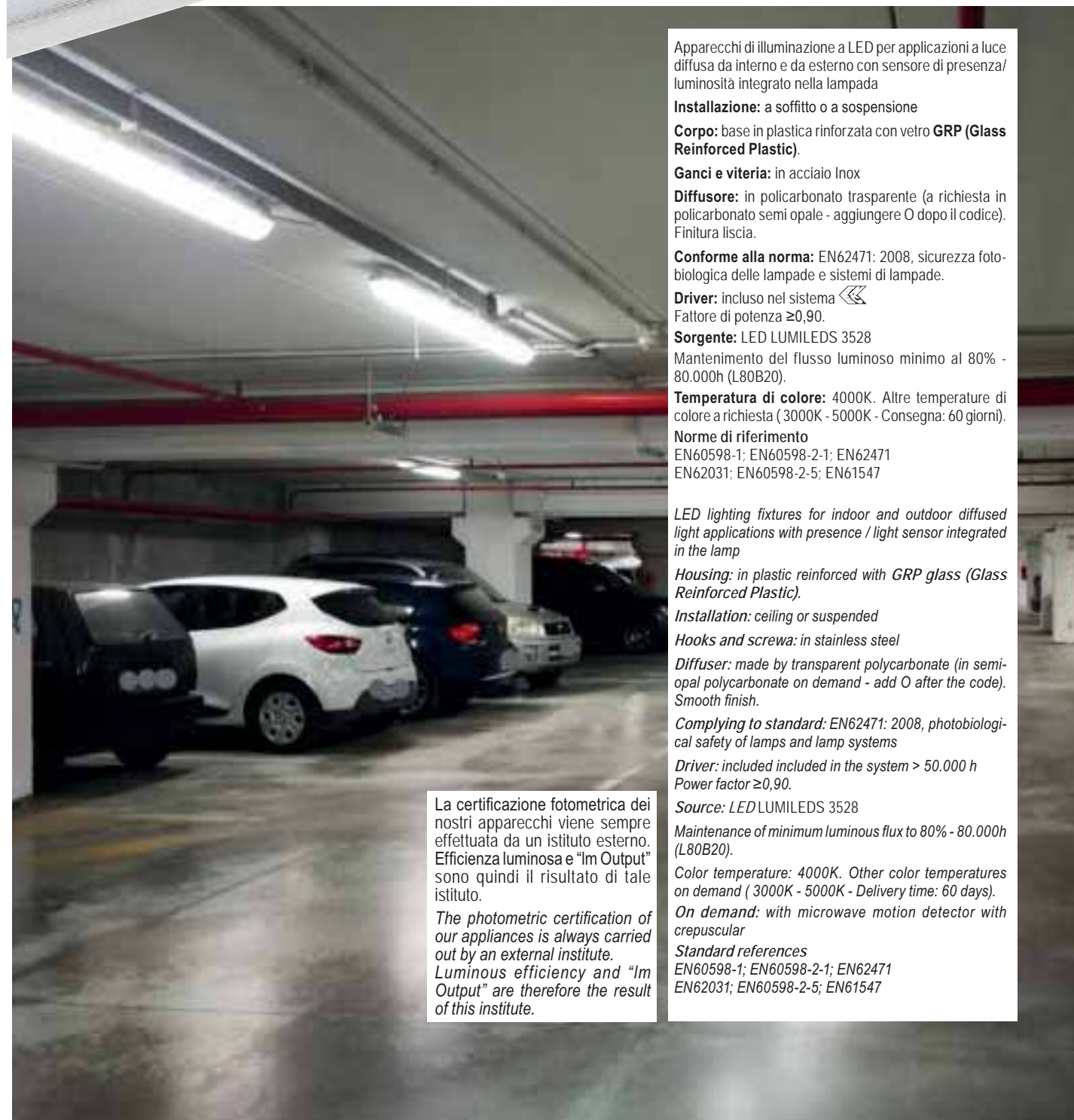



220-240 Vac	50/60 Hz	IP66	IK09	CRI > 80	+50°C -20°C	CE	17 pending			850°	
	LOW FLICKER	Driver included MULTIPOWER		Driver included RIPPLE FREE							

**Luce solo all'occorrenza per un ulteriore risparmio di energia**  
*Light only when needed for further energy saving*

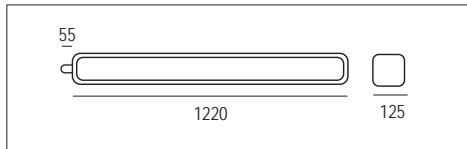
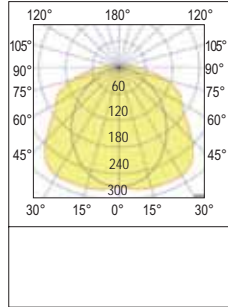

	colour	W	Optic	K	lm output	lm/W	pcs	Kg	CELL
	G	22	110°	4000	3.600	165	1	4,40	32000/F/PUPI
	G	36	110°	4000	6.000	165	1	4,40	32001/F/PUPI
	G	45	110°	4000	7.400	165	1	4,40	32030/FPUPI

**A richiesta: LED Pupilla versione EMERGENZA (aggiungere EM dopo il codice)**  
*On demand: LED Pupilla EMERGENCY version (add EM after the code)*

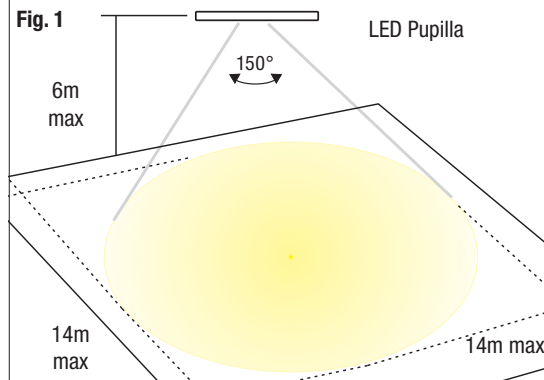
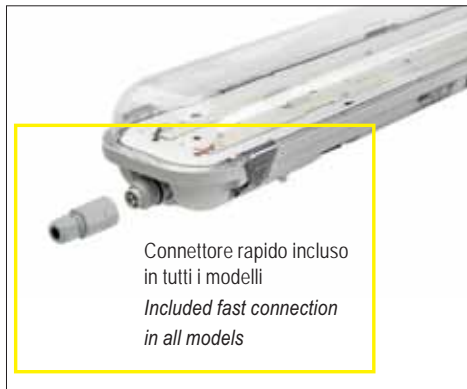

**Funzioni del sensore nell'area di rilevamento (Fig. 1):**

- A - Rileva un movimento e la luce si accende
- B - Se non rileva alcun movimento, a seconda del livello di luminosità rilevato nell'ambiente la luce dopo un certo tempo verrà regolata secondo la programmazione preimpostata oppure si spegnerà dopo un tempo prestabilito

**Sensor functions in the detection area (Fig. 1):**

- A - If it detects movement, the light turns on
- B - If it does not detect any movement, depending on the brightness level detected in the environment the light will be adjusted after a certain time according to the preset schedule or it will turn off after a set time

Quando non viene rilevato alcun movimento la luce rimane accesa a livello preimpostato (10%, 20%, 30% o 50% di luminosità) <i>When no motion is detected the light stays on at a preset level (10%, 20%, 30% or 50% of brightness)</i>	Quando viene rilevato un movimento il sensore accenderà la luce al 100% di luminosità <i>When motion is detected the sensor will turn on the light to 100% brightness</i>	La luce rimarrà accesa al 100% per il tempo di mantenimento preimpostato (5sec, 30sec, 1min, 5min, 10min, 20min e 30min). <i>The light will stay on at 100% for the preset holding time (5sec, 30sec, 1min, 5min, 10min, 20min and 30min).</i>	Quando non viene rilevato alcun movimento e trascorso il tempo di attesa, il sensore dimmerà la luce al livello di luminosità preimpostato (10%, 20%, 30% o 50% di luminosità) <i>When no motion is detected and the waiting time has elapsed, the sensor dims the light to the preset brightness level (10%, 20%, 30% or 50% of brightness)</i>

Quando non viene rilevato alcun movimento la luce rimane spenta <i>When no motion the light stayed off</i>	Quando viene rilevato un movimento il sensore accenderà la luce al 100% di luminosità <i>When motion is detected the sensor will turn on the light to 100% brightness</i>	La luce rimarrà accesa al 100% per il tempo di mantenimento preimpostato (5sec, 30sec, 3min, 5min, 10min, 20min e 30min). <i>The light will stay on at 100% for the preset holding time (5sec, 30sec, 3min, 5min, 10min, 20min and 30min).</i>	Quando non viene rilevato alcun movimento e trascorso il tempo di attesa, il sensore dimmerà la luce al livello di luminosità preimpostato (10%, 20%, 30% o 50% di luminosità) <i>When no motion is detected and the waiting time has elapsed, the sensor dims the light to the preset brightness level (10%, 20%, 30% or 50% of brightness)</i>	Dopo 10min il sensore spegnerà la luce <i>After 10min the sensor will turn off the light</i>

Waterproof luminaires

# LED Allegra ATEX 2-22



Waterproof luminaires

A richiesta - On demand

1-10Vdc

Sensor 

**DALI 2**

Vedi Pag. VI - See page VI

Apparecchio di illuminazione adatto all'ambiente con pericolo di esplosione di gas, polvere e fumi di combustibili. LED Allegra ATEX è conforme ai requisiti richiesti dal decreto governativo 116/2016 Coll. e la Direttiva della Comunità Europea n. 2014/34 / UE

**Installazione:** a soffitto o a sospensione

**Corpo:** in policarbonato Grigio (PC) = alta resistenza meccanica

**Ganci:** acciaio inossidabile + poliammide + 15% fibra di vetro

**Diffusore:** in policarbonato traslucido (PC) = alta resistenza meccanica

**PG:** pressacavo in metallo M20x1,5 ATEX PA66 (cavo Ø 6-12mm<sup>2</sup>)

**Riflettore:** lamiera di acciaio. Colore bianco (RAL9003)

**Driver:**  incluso nel sistema > 50.000 h  
Fattore di potenza ≥0,95.

**Sorgente:** LED. Mantenimento del flusso luminoso minimo al 80% - 80.000h (L80B20) per il 90% dei LED.

**Temperatura di colore:** 4000K

*The light fitting is suitable for the environment with a danger of explosion of gas, dust and combustibles fumes. The light fittings meet the requirements of Government Decree 116/2016 Coll. and European Community Directive No.2014/34/EU*

**Installation:** ceiling or suspended

**Body:** grey polycarbonate (PC) = high mechanical resistance

**Hooks and screw:** in stainless steel

**Clips:** stainless steel + polyamide + 15% glass fibre

**Diffuser:** translucent polycarbonate (PC) = high mechanical resistance

**Metal cable glands:** screwed M20x1,5 (cable Ø 6-12mm<sup>2</sup>)

**Reflector:** steel sheet. White colour (RAL9003)

**Driver:**  included included in the system > 50.000 h.  
Power factor ≥0,95.

**Source:** LED. Maintenance of minimum luminous flux to 80% - 80.000h (L80B20) for 90% of LED.

**Color temperature:** 4000K.





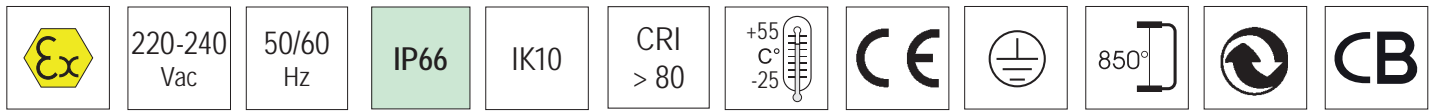

LOW FLICKER

Driver included  
**MULTIPOWER**

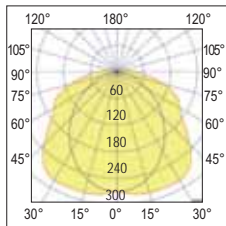
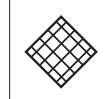

110°  
Diffondente - Wide

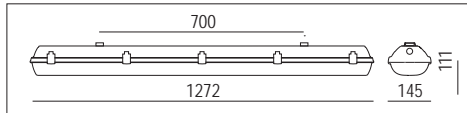

colour	W	Optic	K	lm output	lm/W	pcs	Kg	CELL
G	35 - 42 - 50	110°	4000	Vedi tabella See table	156	1	3,40	32030/AXT

AUTOTEST								
colour	W	Optic	K	lm output	lm/W	pcs	Kg	CELL-E
G	35	110°	4000	Vedi tabella See table	156	1	3,20	32001/AXTEM
G	42	110°	4000		156	1	3,40	32030/AXTEM
G	50	110°	4000		156	1	3,50	32031/AXTEM

Protezione da atmosfere esplosive <i>Protection against explosive atmospheres</i>	CE Ex II 3G Ex nR IIC T6 Gc
Zona pericolosa ammessa - <i>Hazardous area allowed</i>	Zona 2 - Zone 2 / Zona 22 - Zone 22
Normative di riferimento - <i>Standard references</i>	EN60079-0 / EN60079-15 / EN60079-31

**Accessori inclusi - Included accessories**



Staffa di fissaggio a parete/plafone in acciaio inox. Tasselli e viti non compresi. Per l'installazione a parete o soffitto utilizzare tasselli e viti adeguati alla superficie su cui andrà ancorata - *Wall/ceiling fixing bracket made by stainless steel. Plug and screws are not included. For ceiling or wall installation use plug and screws adapted to surface upon which it will be anchored.*

**Flusso/potenza regolabili manualmente - Flux / power manually adjustable**

Per una corretta gestione dell'impianto di illuminazione, bisogna sempre tenere conto sia della necessità di illuminamento realizzato tramite calcolo illuminotecnico, che il rispetto dei consumi energetici.

I nostri modelli LED Gioia permettono di ottenere questo risultato poiché sono dotati di Driver multipower; questi particolari Driver consentono di impostare la corrente in uscita tramite dip-switch, fornendo, di conseguenza, la corretta potenza di lampada in base all'esigenza desiderata, permettendo quindi sia il risparmio energetico che il rispetto del flusso luminoso determinato in fase di progetto.

*For proper management of the lighting system, it is always necessary to take into account both the need for lighting achieved through lighting engineering calculations, and respect for energy consumption.*

*Our LED Gioia models allow to obtain this result as they are equipped with multipower Driver; these particular drivers allow you to set the output current via dip-switches, thus providing the correct lamp power based on the desired need, thus allowing both energy savings and respect for the luminous flux determined in the design phase.*

**LED Driver multipotenza incluso  
LED Driver multipower included**

I mA	W	Lm output
350	35	5.460
420	42	6.550
500	50	7.800
Taratura di fabbrica Factory setting		



Dip switch per la selezione della corrente in uscita  
*Equipped with dip switch for selection the output current*



Possibilità di collegamento passante in fila continua (accessori inclusi).  
*Possibility of through connection in continuous line (accessories included).*



Morsettiera 5 poli per ripartizione su linea trifase.  
*5-pole terminal block for distribution on three-phase line.*

Waterproof luminaires



# LED Allegra Metal Predisposta per cablaggio in fila continua - Prepared for loop in - loop out





Apparecchio stagno di illuminazione a LED per applicazioni a luce diffusa da interno e da esterno. Adatto all'illuminazione di stabilimenti di produzione, magazzini, depositi.

**Installazione:** a soffitto o a sospensione  
**Corpo:** corpo in acciaio stampato in un unico pezzo di elevata resistenza meccanica

**Ganci:** in acciaio inossidabile AISI 304

**Diffusore:** in policarbonato opale autoestinguente V2 stabilizzato ai raggi UV.

**Driver:** multipotenza incluso > 50.000 h   
 Fattore di potenza ≥ 0.95.

**Sorgente:** LED  **Mantenimento del flusso luminoso** minimo al 80.000h (L80B20) per il 90% dei LED.

**Norme di riferimento**

EN60598-1; EN60598-2-1; EN62471; EN61547

**Classificazione rischio fotobiologico:** gruppo esente

**A richiesta:** 3000K o 6000K con sovrapprezzo di 30,00 Euro  
 Direttiva HACCP per gli impianti illuminotecnici nelle industrie alimentari

*LED waterproof luminaire for diffused indoor and outdoor light applications.*

*Suitable for lighting production facilities, warehouses, warehouses, pavilions, workshop areas and large areas in general.*

*Installation: ceiling or suspended*

*Body: body in pressed steel in a single piece of high mechanical resistance*

*Clips: in AISI 304 stainless-steel*

*Diffuser: in self-extinguishing opal polycarbonate V2 UV stabilised*

*Driver: multipower cluded > 50.000 h *

*Power factor ≥ 0.95.*

*Source: LED  **Maintenance of minimum luminous flux** to 80% - 80.000h (L80B20) for 90% of LED.*

*Standard references*

*EN60598-1; EN60598-2-1; EN62471; EN61547*

*Photobiological risk classification: no risk*

*Upon request: 3000K or 6000K with a 30.00 Euro extra charge  
 HACCP directive for lighting systems in food industries*

La certificazione fotometrica dei nostri apparecchi viene sempre effettuata da un istituto esterno. Efficienza luminosa e "lm Output" sono quindi il risultato di tale istituto.

*The photometric certification of our appliances is always carried out by an external institute. Luminous efficiency and "lm Output" are therefore the result of this institute.*

**A richiesta - On demand**



**Consegna 30 gg - Delivery 30 days**

Vedi Pag. VI - See page VI

Waterproof luminaires

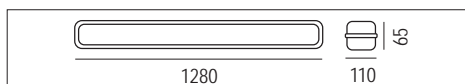
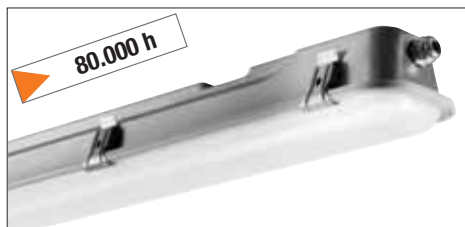

**A richiesta:** lunghezza 650mm o 1560mm.  
 Consegna 90 giorni.  
*On request: length 650mm or 1560mm  
 Delivery 90 days.*

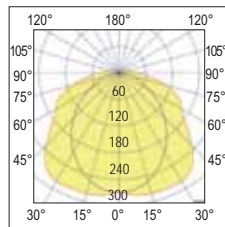

**110°**  
 Diffondente - Wide

220-240 Vac	50/60 Hz	IP65	IK06	IK09	<b>A richiesta On demand</b>
		85°			



**CRI > 80**



LED Driver multipotenza incluso LED Driver multipower included				
PIN 1	PIN 2	I mA	W	Lumen output
OFF	OFF	900	48*	5.800
OFF	ON	1.050	56	7.200
ON	OFF	1.100	60	7.730
ON	ON	1.200	65	8.500
Settaggio di fabbrica - Factory setting				



Dip switch per la selezione della corrente in uscita  
 Equipped with dip switch for selection the output current

	colour	W	Optic	K	lm output	lm/W	pcs	Kg	CELL
	A	45* - 56 - 65	120°	4000	See Table	130	1	6,60	32031/60/MET
<b>1-10Vdc</b>	A	45* - 56 - 65	120°	4000	See Table	130	1	6,60	32031/60/M010
<b>DALI 2</b>	A	45* - 56 - 65	120°	4000	See Table	130	1	6,60	32031/60/MDAL
<b>AUTOTEST</b>	A	45* - 56 - 65	120°	4000	See Table	1	1	6,60	CELL-E 32031METEM
<b>AUTOTEST</b>	A	45* - 56 - 65	120°	4000	See Table	1	1	6,60	CELL-E 3203160M010EM
<b>AUTOTEST</b>	A	45* - 56 - 65	120°	4000	See Table	1	1	6,60	CELL-E 3203160MDALEM

# LED Allegra Metal

Accessori NON inclusi - *NOT included accessories*



**Cod. 000151**  
Kit 2 ganci sicurezza anticaduta - *Kit of 2 safety hooks against fall*

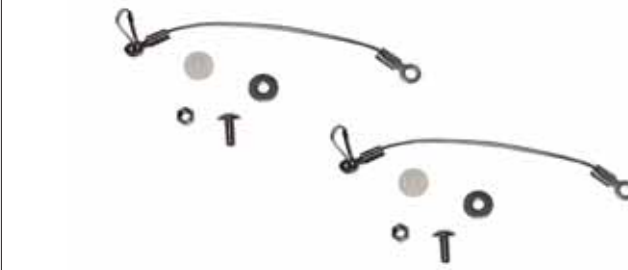

**Accessori inclusi - *Included accessories***

Kit per montaggio a plafone  
*Ceiling mounting kit*



Possibilità di collegamento passante in fila continua (accessori inclusi).

*Possibility of through connection in continuous line (accessories included).*

**N° massimo di apparecchi collegabili per ogni linea elettrica**  
*Maximum number of devices that can be connected to any electrical line*

W Puissance - Leistung	N° maximum d'appareils Max. Anzahl der Geräte
45	26
56	30
65	20

**A richiesta - *On demand***



**Emergency**

Con cablaggio in emergenza ad alimentazione centralizzata. Apparecchio permanente, con alimentatore funzionante AC/DC, alimentato da un sistema di emergenza centralizzato, cioè non incorporato nell'apparecchio

*With centralized emergency wiring. Permanent device, with AC / DC power supply, powered by a centralized emergency system, i.e. not incorporated into the device*



Waterproof luminaires



# LED Lanterna

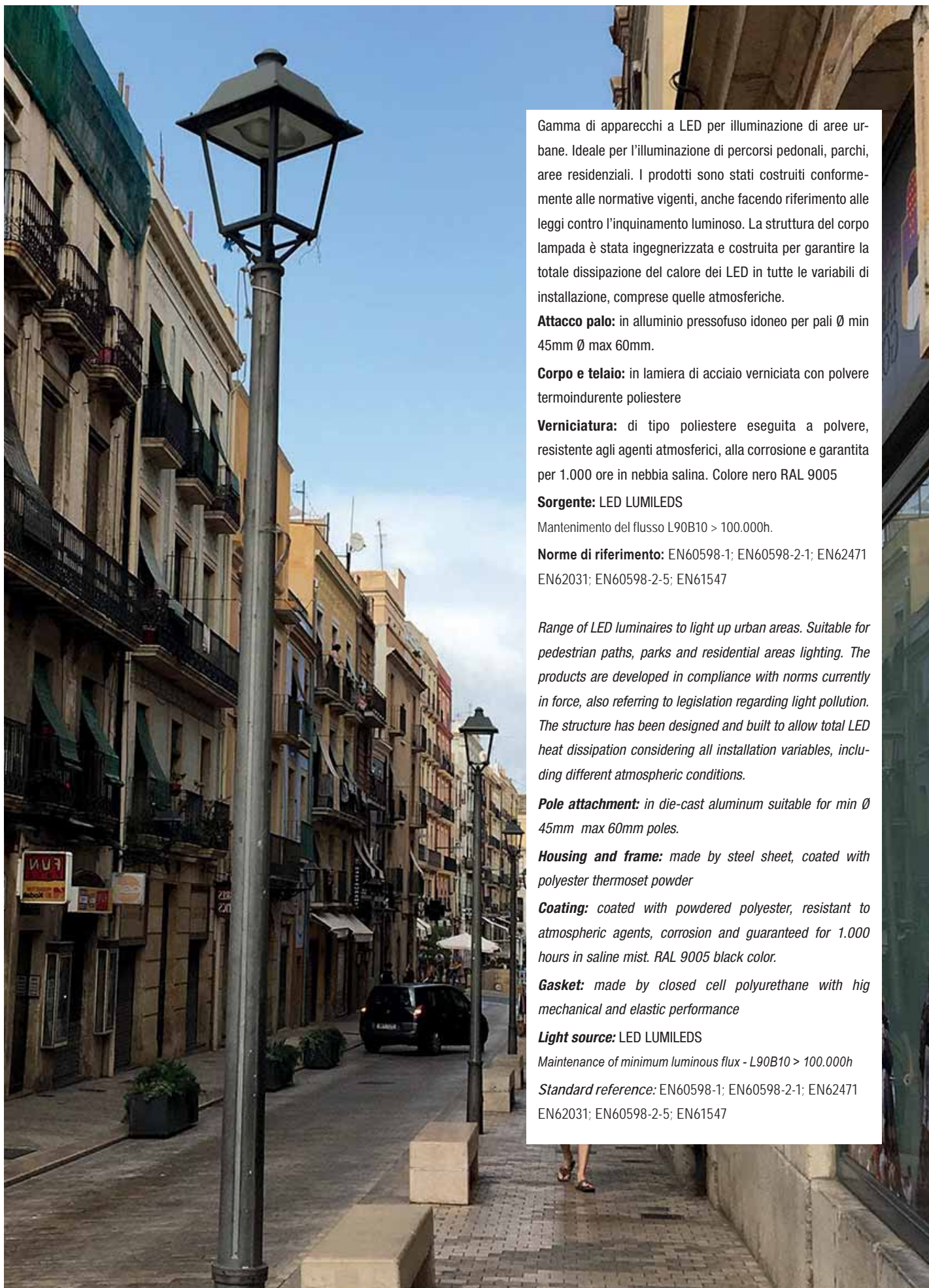

Gamma di apparecchi a LED per illuminazione di aree urbane. Ideale per l'illuminazione di percorsi pedonali, parchi, aree residenziali. I prodotti sono stati costruiti conformemente alle normative vigenti, anche facendo riferimento alle leggi contro l'inquinamento luminoso. La struttura del corpo lampada è stata ingegnerizzata e costruita per garantire la totale dissipazione del calore dei LED in tutte le variabili di installazione, comprese quelle atmosferiche.

**Attacco palo:** in alluminio pressofuso idoneo per pali Ø min 45mm Ø max 60mm.

**Corpo e telaio:** in lamiera di acciaio verniciata con polvere termoindurente poliestere

**Verniciatura:** di tipo poliestere eseguita a polvere, resistente agli agenti atmosferici, alla corrosione e garantita per 1.000 ore in nebbia salina. Colore nero RAL 9005

**Sorgente:** LED LUMILEDS

Mantenimento del flusso L90B10 > 100.000h.

**Norme di riferimento:** EN60598-1; EN60598-2-1; EN62471 EN62031; EN60598-2-5; EN61547

*Range of LED luminaires to light up urban areas. Suitable for pedestrian paths, parks and residential areas lighting. The products are developed in compliance with norms currently in force, also referring to legislation regarding light pollution. The structure has been designed and built to allow total LED heat dissipation considering all installation variables, including different atmospheric conditions.*

**Pole attachment:** in die-cast aluminum suitable for min Ø 45mm max 60mm poles.

**Housing and frame:** made by steel sheet, coated with polyester thermoset powder

**Coating:** coated with powdered polyester, resistant to atmospheric agents, corrosion and guaranteed for 1.000 hours in saline mist. RAL 9005 black color.

**Gasket:** made by closed cell polyurethane with high mechanical and elastic performance

**Light source:** LED LUMILEDS

Maintenance of minimum luminous flux - L90B10 > 100.000h

**Standard reference:** EN60598-1; EN60598-2-1; EN62471 EN62031; EN60598-2-5; EN61547



100-240  
Vac

50/60  
Hz

IP66

IK08

CRI  
> 70



Driver included

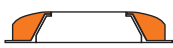

RG0



LOW  
FLICKER

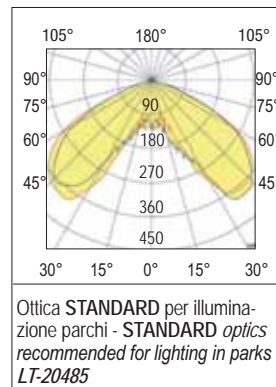
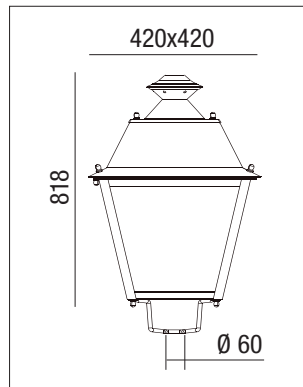

colour	W	Optic	K	lm output	lm/W	pcs	Kg	CELL
N	24	ST	2200	3.200	130	1	8,20	LANT2422K
N	24	ST	3000	3.250	135	1	8,20	LANT243K
N	24	ST	4000	3.480	145	1	8,20	LANT244K
N	56	ST	2200	7.280	130	1	8,20	LANT5622K
N	56	ST	3000	7.560	135	1	8,20	LANT563K
N	56	ST	4000	8.120	145	1	8,20	LANT564K
N	75	ST	2200	9.750	130	1	8,20	LANT7522K
N	75	ST	3000	10.100	135	1	8,20	LANT753K
N	75	ST	4000	10.900	145	1	8,20	LANT754K



Street furniture

Esempi applicativi - Application example



**A richiesta (richiedere codice prodotto agli uffici commerciali)**  
**On demand (request code product to commercial offices)**  
 Staffa superiore per applicazione a parete  
*Upper bracket for wall application*



**A richiesta (richiedere codice prodotto agli uffici commerciali)**  
**On demand (request code product to commercial offices)**  
 Staffa inferiore per applicazione a parete  
*Lower bracket for wall application*



**A richiesta (richiedere codice prodotto agli uffici commerciali)**  
**On demand (request code product to commercial offices)**  
 Diffusore in vetro  
*Glass diffusor*

Cod. VETTRASFORO  
 Con foro per Lanterna con alimentazione dal basso  
*With hole for Lanterna with power supply from below*



Cod. VETTRASNOFORO  
 Senza foro per Lanterna con alimentazione dall'alto  
*Without hole for Lanterna with power supply from above*



NON inclusa  
 NOT included

Incluso  
 Included

**A richiesta (richiedere codice prodotto agli uffici commerciali)**  
**On demand (request code product to commercial offices)**  
 Catena per applicazione a sospensione  
*Chain for suspension application*

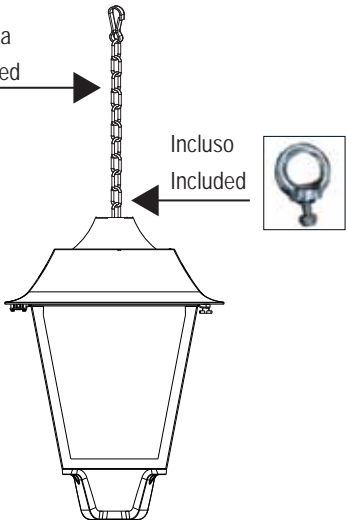

**Settaggio del flusso luminoso:** avviene tramite programmazione della corrente di pilotaggio da richiedere in sede in fase d'ordine / progetto  
**Luminous flux setting:** takes place by programming the driving current to be requested at the time of the order / project

DYNA CONTROL è un sistema automatico di controllo del flusso luminoso delle lampade. Il sistema entra in funzione alla prima accensione calcolando per 3 giorni i tempi di accensione, il quarto giorno il sistema in modo autonomo, calcola la mezzanotte virtuale eseguendo una regolazione del flusso regolando la lampada come indicato sullo schema di Fig. 1; per i primi tre giorni, quindi, il sistema manterrà le lampade accese al 100%, nel tempo di accensione dell'impianto, il quarto giorno entrerà in funzione il sistema DYNA CONTROL gestendo in modo autonomo il flusso luminoso garantendo così un notevole risparmio energetico.

Accensioni inferiori ad 1 ora (es. manutenzione) verranno ignorate ed il sistema non entra in funzione, per accensioni da 1 a 4 ore (es. anomalia impianto) o superiori alle 23 ore (es. impianto sempre acceso), il sistema resetta il timer quindi ricomincerà a contare per i primi 3 giorni e successivamente riprenderà il funzionamento automatico.

*DYNA CONTROL is an automatic control system for the luminous flux of the lamps. The system comes into operation at the first start-up by calculating the ignition times for 3 days, on the fourth day the system autonomously calculates the virtual midnight by adjusting the flow by adjusting the lamp as indicated in the diagram in Fig. 1; for the first three days, therefore, the system will keep the lamps on at 100%, during the system start-up time, on the fourth day the DYNA CONTROL system will come into operation, independently managing the luminous flux thus ensuring significant energy savings.*

*Switch-ons of less than 1 hour (e.g. maintenance) will be ignored and the system does not start up, for switch-ons from 1 to 4 hours (e.g. system anomaly) or longer than 23 hours (e.g. system always on), the system resets the timer will then start counting again for the first 3 days and will then resume automatic operation.*

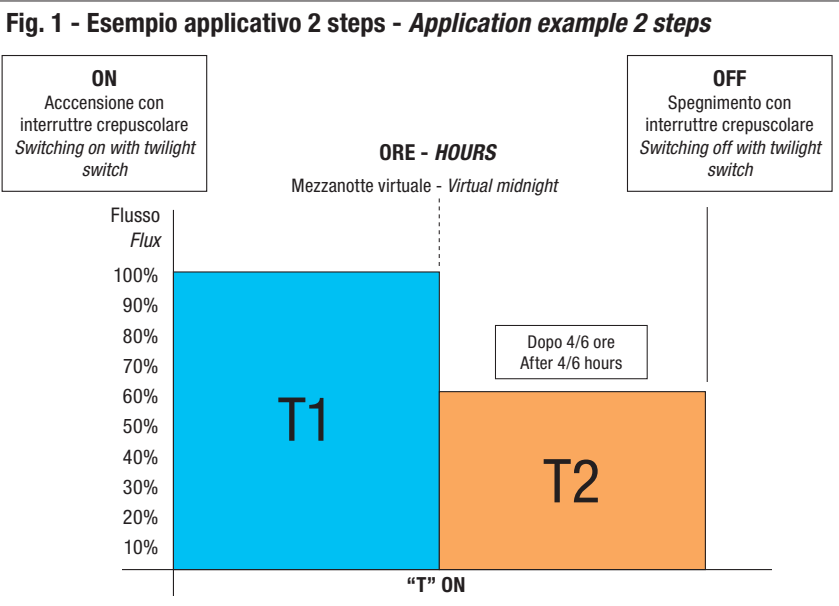



# LED Lanterna NEW

UPGRADE LED per LANTERNE  
UPGRADE LED for LANTERNE



100-240  
Vac

50/60  
Hz



IP66

IK10



CRI  
>70

## La soluzione di relamping LED permette:

- Riduzione dei costi di intervento e manutenzione.
- Facilità di installazione senza modifiche strutturali

## The LED relamping solution allows:

- Cost reduction of intervention and maintenance.
- Easy installation without structural modifications



VECCHIO - OLD



260x190x75mm



275x200x80mm

NUOVO - NEW



**Materiale:** alluminio di elevata purezza  
**Diffusore:** vetro trasparente  
**Finitura:** silver  
**Potenza:** 20÷80W - 100 Lm/W  
**Ottiche:** 4 modelli in PMMA  
**Temperatura di colore:** 2.2K - 2.7K - 3K  
**LED:** CREE 3535  
**Prezzo:** On demand

**Structure material:** high purity aluminium  
**Diffuser material:** transparent glass  
**Structure finish:** silver  
**Power:** 20÷80W - 100 Lm/W  
**Optical:** 4 models PMMA  
**Color temperature:** 2.2K - 2.7K - 3K  
**LED:** CREE 3535  
**Price:** On demand

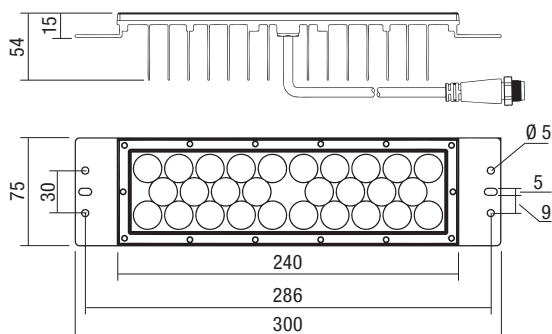

Corrente nominale (Max) - Rated current (Max)	720 mA	930 mA	1140 mA	1330 mA
Tensione massima - Max forward voltage	42V	42V	44V	45V
Potenza massima - Max power	30W	40W	50W	60W
Flusso luminoso - Luminous flux	5700 Lm	7200 Lm	8500 Lm	9600 Lm
Efficienza - Efficiency	190 Lm/W	180 Lm/W	170 Lm/W	160 Lm/W

LED 5050 - Colorazione 3K - 4  
L90B10 > 100.000h.

LED 5050 - Coloring 3K - 4  
L90B10 > 100.000h.



## LED Lanterne speciali complete di palo A RICHIESTA - LED Special lanterns complete with pole ON REQUEST

**Componenti:**

pressofusione di alluminio EN AB 46100, verniciato con polveri poliesteri ad elevata resistenza ai raggi UV e alla corrosione

**Diffusori:**

vetro chiaro trasparente  
vetro satinato (opzionale)  
policarbonato trasparente (opzionale)

**Components:**

EN AB 46100 die-cast aluminium, painted with polyester powders with high resistance to UV rays and corrosion

**Diffuser:**

clear transparent glass  
frosted glass (optional)  
transparent polycarbonate (optional)

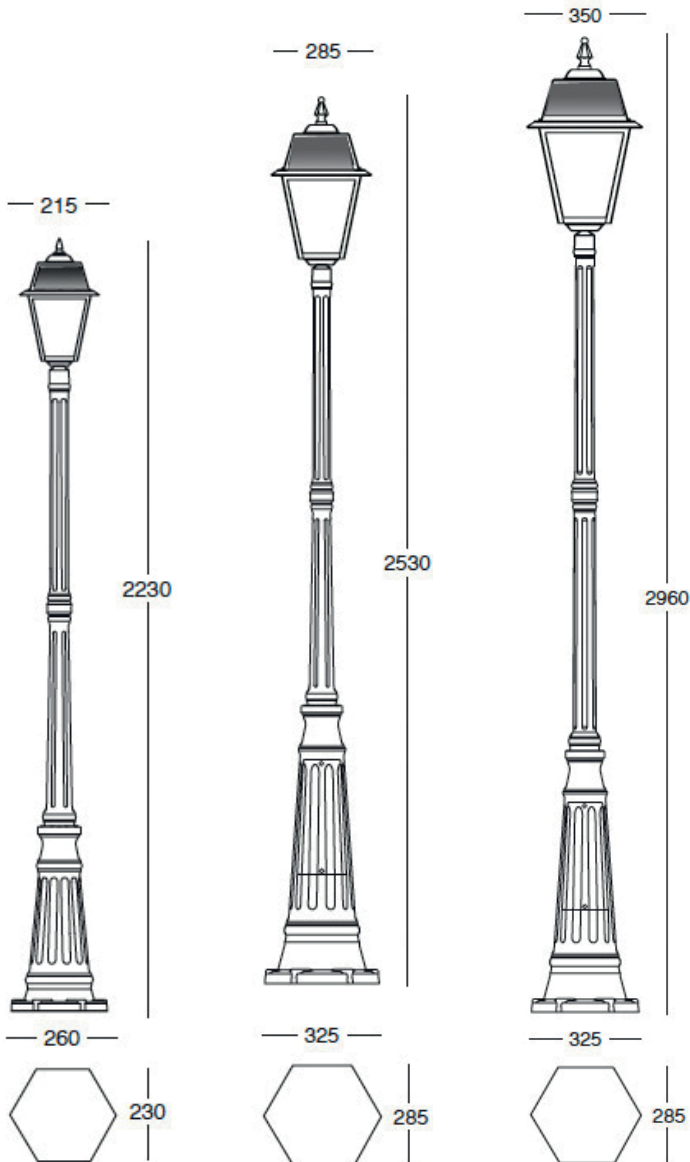
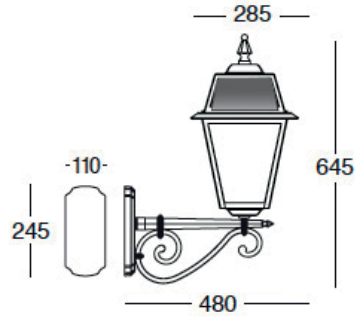



# PALO LUMINOSO QUADRATO A RICHIESTA - SQUARE LUMINOUS POLES ON REQUEST



Street furniture

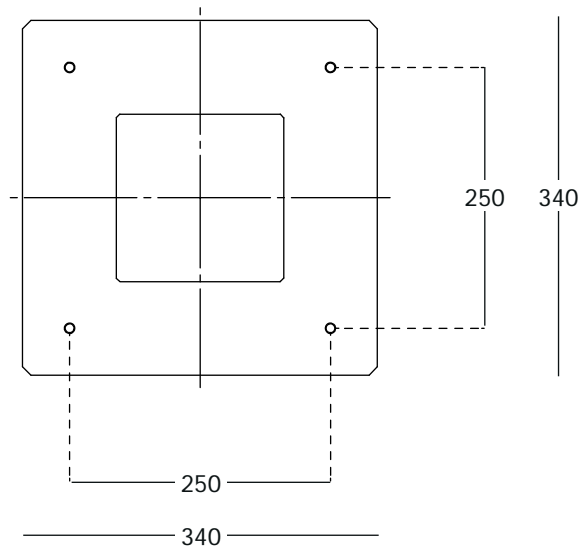
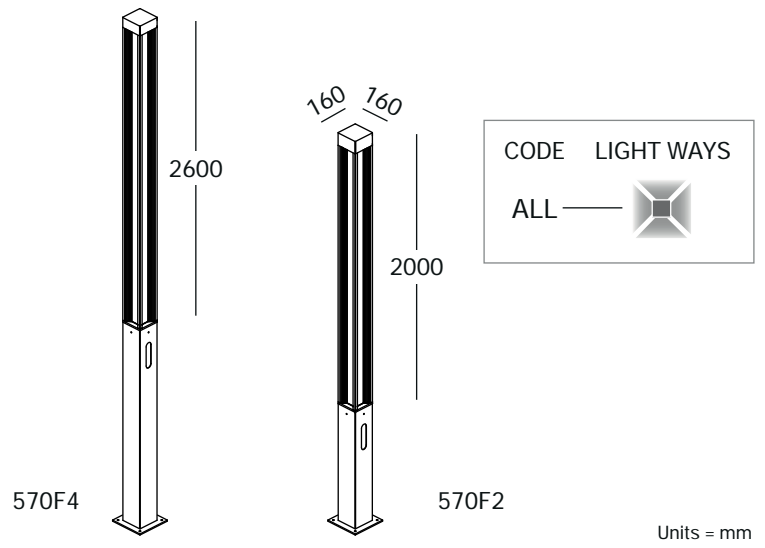
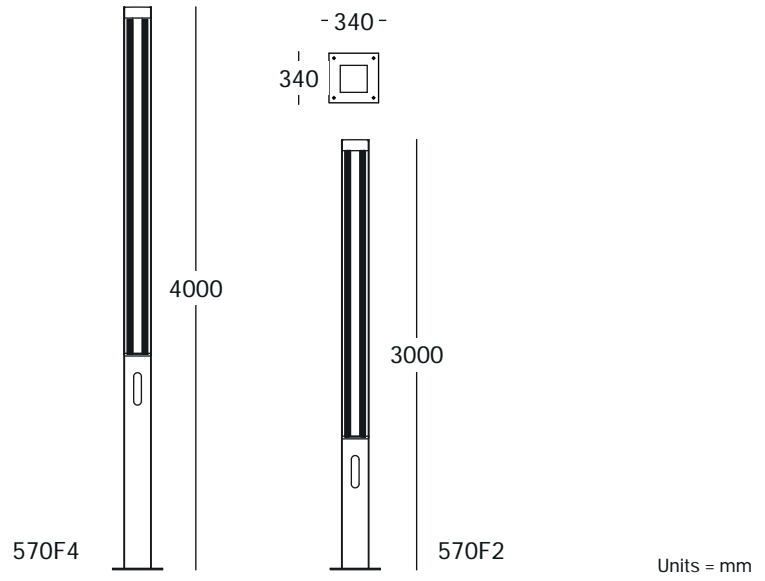



# PALO LUMINOSO TONDO A RICHIESTA - ROUND LUMINOUS POLES ON REQUEST

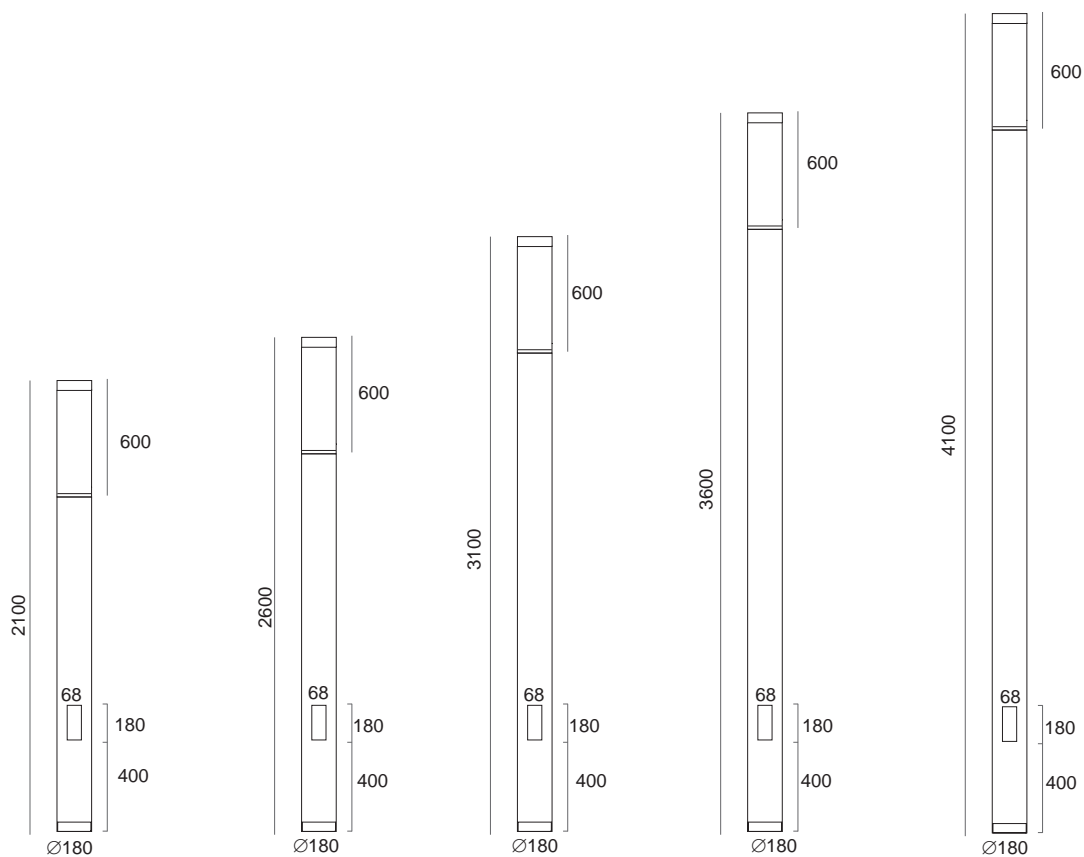

Street furniture

# LED Lampione 2 - 4 - 6 - 7 - 8 - 9 - 10 - 12



Gamma di apparecchi a LED per illuminazione di aree urbane. Ideale per l'illuminazione di percorsi pedonali, parchi, aree residenziali. I prodotti sono stati costruiti conformemente alle normative vigenti, anche facendo riferimento alle leggi contro l'inquinamento luminoso.

**Attacco palo:** in alluminio pressofuso idoneo per pali Ø min 45mm Ø max 60mm.

**Corpo e bracci:** in alluminio pressofuso UNI 5076 verniciato con polvere termoindurente poliestere garantita per 1.500 ore in nebbia salina.

**Ottiche:** in PMMA con resistenza alle alte temperature e ai raggi UV.

**Verniciatura LED Lampione 2:** di tipo poliestere eseguita a polvere, resistente agli agenti atmosferici, alla corrosione e garantita per 1.500 ore in nebbia salina. Colore Nero RAL 9005

**Verniciatura LED Lampione 4 / 6 / 7 / 8 / 9 / 10 / 12:** il ciclo di verniciatura standard a liquido, ad immersione, è composto da diverse fasi.

Una prima fase di pretrattamento superficiale del metallo, poi una verniciatura in cataforesi episodica resistente alla corrosione e alle nebbie saline, poi una mano finale di liquido bicomponente acrilico, stabilizzato ai raggi UV. Per ambienti marini (fronte mare) conforme alla Norma UNI EN ISO 9227 (circa 1.000 ore)

- Grigio RAL 9007 (a richiesta RAL 9005)

**Schermo:** vetro temperato di spessore 4mm resistente agli shock termici (Lampione 2). In policarbonato spessore 2,5mm resistente agli shock termici e agli urti (Lampione 4). Vetro temperato di spessore 4mm colore nero resistente agli shock termici (Lampione 6 - 7 - 8 - 9 - 10 - 12).

**Sorgente:** LED **SAMSUNG** - LUMILEDS  
Mantenimento del flusso L90B10 > 100.000h.

**Temperatura di colore:** 2200K, 3000K e 4000K.  
CRI >70

**Driver:** incorporato . Fattore di potenza ≥0,98.

**A richiesta:** Il settaggio del flusso luminoso può essere modificato tramite programmazione della corrente di pilotaggio da richiedere in sede in fase d'ordine.

**Protezione alle sovratensioni secondo le normative vigenti.**

A richiesta modo differenziale 6kV (L-N)  
modo comune 8kV (L-GND, N-GND, L & N-GND)

**Norme di riferimento:**  
IEC 61000-4-5; EN60598-1; EN60598-2-1; EN62471; EN62031; EN60598-2-5; EN61547

*Range of LED luminaires for urban lighting. Ideal for lighting pedestrian walkways, parks, residential areas. The products have been built in accordance with current regulations, also referring to the laws against light pollution.*

**Pole attachment:** in die-cast aluminum suitable for min Ø 45mm max 60mm poles.

**Body and arms:** in die-cast aluminum UNI 5076 painted with thermosetting polyester powder guaranteed for 1,500 hours in saline mist.

**Optics:** in PMMA with resistance to high temperatures and UV rays.

**Painting LED Lampione 2:** polyester powder type, resistant to atmospheric agents, corrosion and guaranteed for 1,500 hours in saline mist.

- Black color RAL 9005

**Painting LED Lampione 4 / 6 / 7 / 8 / 9 / 10 / 12:** the standard liquid painting cycle, by immersion, is made up of different phases.

A first phase of surface pre-treatment of the metal, then an episodic cathodesis painting resistant to corrosion and salt spray, then a final coat of two-component acrylic liquid, stabilized against UV rays. For marine environments (seafront) compliant with the UNI EN ISO 9227 standard (approximately 1,000 hours)

- Grey RAL 9007 (on demand RAL 9005)

**Screen:** 4mm thick tempered glass resistant to thermal shock (Lamp post 2). In polycarbonate 2,5 mm thick, resistant to thermal shocks and impacts (Lamp 4). 4mm thick black tempered glass resistant to thermal shock (Lamp 6 - 7 - 8 - 9 - 10 - 12).

**Source:** LED **SAMSUNG** - LUMINLEDS  
Maintenance of minimum luminous flux - L90B10 > 100.000h .

**Color temperature:** 2200K, 3000K and 4000K. CRI >70  
**Driver:** built-in. Power factor ≥0.98.

**On request:** The setting of the luminous flux can be changed by programming the driving current to be requested when ordering.

**Overvoltage protection according to current regulations.**

On request 6kV differential mode (L-N)  
Common mode 8kV (L-GND, N-GND, L & N-GND)

**Reference standards:**  
IEC 61000-4-5; EN60598-1; EN60598-2-1; EN62471; EN62031; EN60598-2-5; EN61547

# LED Lampione 2 - 4 - 6 - 7 - 8 - 9 - 10 - 12



A richiesta - On demand

1-10Vdc

DALI 2

DYNA

Wireless

Vedi Pag. VI - See page VI

## DYNA control - Mezzanotte virtuale - Virtual midnight

**Settaggio del flusso luminoso:** avviene tramite programmazione della corrente di pilotaggio da richiedere in sede in fase d'ordine / progetto  
**Luminous flux setting:** takes place by programming the driving current to be requested at the time of the order / project

DYNA CONTROL è un sistema automatico di controllo del flusso luminoso delle lampade. Il sistema entra in funzione alla prima accensione calcolando per 3 giorni i tempi di accensione, il quarto giorno il sistema in modo autonomo, calcola la mezzanotte virtuale eseguendo una regolazione del flusso regolando la lampada come indicato sullo schema di Fig. 1; per i primi tre giorni, quindi, il sistema manterrà le lampade accese al 100%, nel tempo di accensione dell'impianto, il quarto giorno entrerà in funzione il sistema DYNA CONTROL gestendo in modo autonomo il flusso luminoso garantendo così un notevole risparmio energetico.

Accensioni inferiori ad 1 ora (es. manutenzione) verranno ignorate ed il sistema non entra in funzione, per accensioni da 1 a 4 ore (es. anomalia impianto) o superiori alle 23 ore (es. impianto sempre acceso), il sistema resetta il timer quindi ricomincerà a contare per i primi 3 giorni e successivamente riprenderà il funzionamento automatico.

*DYNA CONTROL is an automatic control system for the luminous flux of the lamps. The system comes into operation at the first start-up by calculating the ignition times for 3 days, on the fourth day the system autonomously calculates the virtual midnight by adjusting the flow by adjusting the lamp as indicated in the diagram in Fig. 1; for the first three days, therefore, the system will keep the lamps on at 100%, during the system start-up time, on the fourth day the DYNA CONTROL system will come into operation, independently managing the luminous flux thus ensuring significant energy savings.*

*Switch-ons of less than 1 hour (e.g. maintenance) will be ignored and the system does not start up, for switch-ons from 1 to 4 hours (e.g. system anomaly) or longer than 23 hours (e.g. system always on), the system resets the timer will then start counting again for the first 3 days and will then resume automatic operation.*

**Fig. 1**

### Esempio applicativo 2 steps - Application example 2 steps

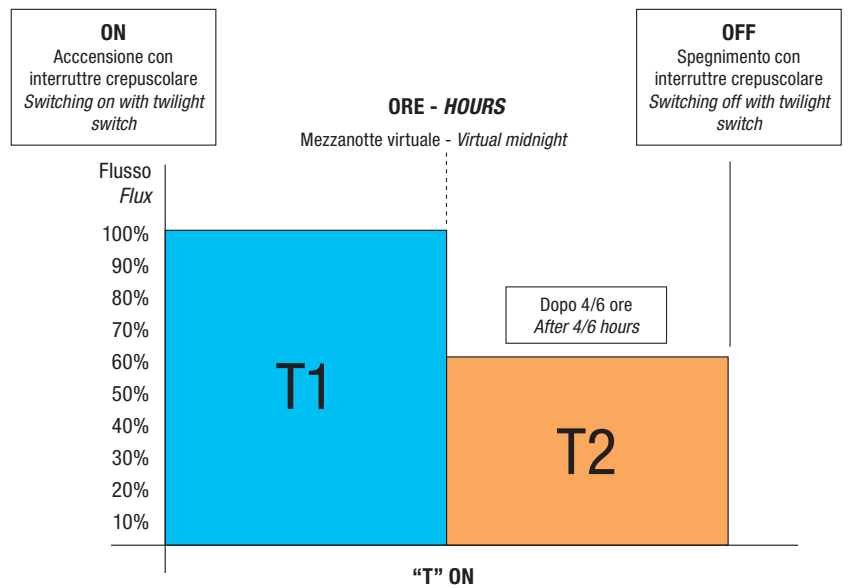

**T1** = 100% Flusso luminoso - Luminous flux

**T2** = 70% Flusso luminoso - Luminous flux

Minimo tempo di accensione per funzionamento automatico 4 ore (3 giorni).

Accensioni di 1 ora ignorate.

Accensioni da 1 a 4 ore oppure superiori alle 23 ore resettano il sistema.

*The minimum ignition time for automatic operation is 4 hours (three days).*

*Ignitions 1 hour ignored.*

*Switching from 1 to 4 hours or higher with 23 hours reset the system.*





LED Lampione 2



LED Lampione 4

**Apparecchio predisposto  
all'installazione su palo  
(Vedi Pag. 102)  
Device designed for pole  
installation (See page 102)**

## LED Lampione 2



A richiesta: 2200K  
On demand: 2200K

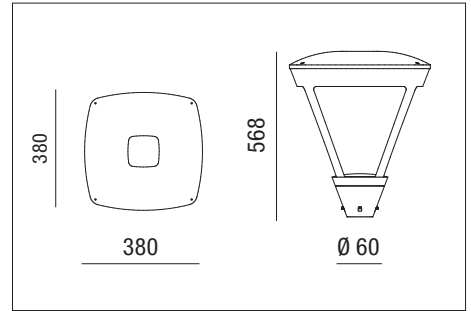
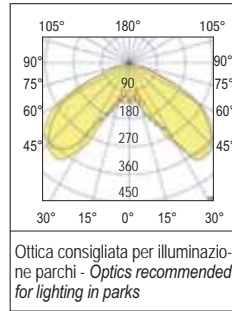
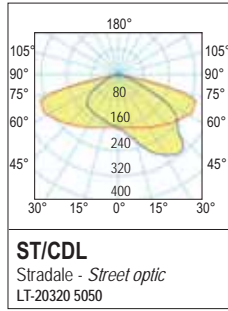

220-240 Vac    110 Vac a richiesta on demand    50/60 Hz    IP66    IK08    +50°C -20°C    0,37 m<sup>2</sup>    850°    CRI >70    CE

DRIVER INCLUDED    RGO    LOW FLICKER

colour	W	Optic	K	lm output	lm/W	pcs	Kg	CELL
N	24	ST	3000	2.880	120	1	9,00	31510/3KS
N	24	ST	4000	2.880	120	1	9,00	31510S
N	40	ST	3000	4.800	120	1	9,00	31512/3KS40
N	56	ST	3000	6.720	120	1	9,00	31512/3KS
N	56	ST	2200	6.720	120	1	9,00	31512/2KS
N	56	ST	2700	6.720	120	1	9,00	31512/27KS
N	56	ST	4000	6.720	120	1	9,00	31512S
N	75	ST	3000	9.000	120	1	9,00	31513/3KS
N	75	ST	4000	9.000	120	1	9,00	31513S

## LED Lampione 4



A richiesta: 2200K  
On demand: 2200K

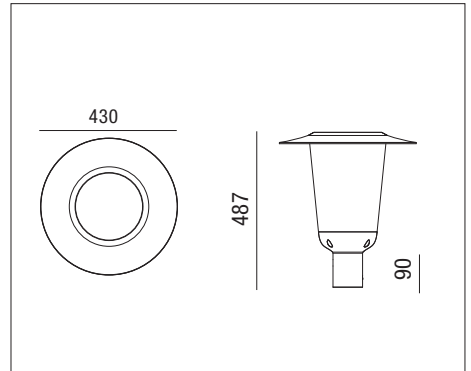
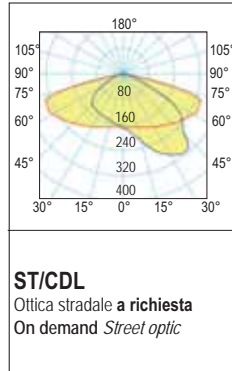
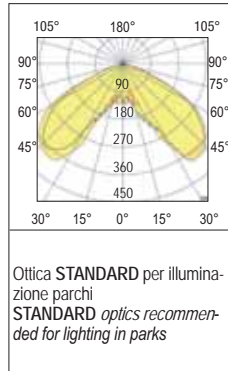

220-240 Vac    110 Vac a richiesta on demand    50/60 Hz    IP66    IK08    +50°C -20°C    0,37 m<sup>2</sup>    850°    CRI >70    CE

DRIVER INCLUDED    RGO    LOW FLICKER

colour	W	Optic	K	lm output	lm/W	pcs	Kg	CELL
G	24	PK	3000	2.880	120	1	9,00	32510/3KS
G	24	PK	2200	2.880	120	1	9,00	32510/2KS
G	24	PK	4000	2.880	120	1	9,00	32510S
G	56	PK	3000	6.720	120	1	9,00	32512/3KS
G	56	PK	2200	6.720	120	1	9,00	32512/2KS
G	56	PK	4000	6.720	120	1	9,00	32512S
G	75	PK	3000	9.000	120	1	9,00	32513/3KS
G	75	PK	4000	9.000	120	1	9,00	32513S

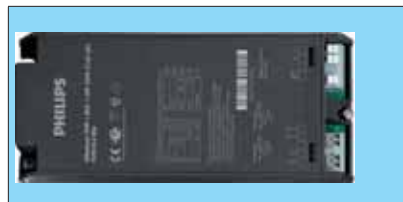

Tutti gli apparecchi di illuminazione di questo catalogo utilizzano un Driver LED "MULTIPOWER". A richiesta, per quantità, è possibile cambiare in fabbrica la taratura della corrente e, di conseguenza, potenza (W) e Lumen (Lm)

All the luminaires in this catalog use a "MULTIPOWER" LED Driver.  
On request, for quantity, it is possible to change the current calibration in the factory and, consequently, power (W) and Lumen (Lm)

## LED Lampione 6 - 7



LED Lampione 6



LED Lampione 7

**Apparecchio predisposto all'installazione  
su palo (Vedi Pag. 102)**

**Device designed for pole installation  
(See page 102)**



## LED Lampione 6



**A richiesta**  
Nero RAL 9005.  
Aggiungere BL dopo il codice  
On demand  
Black RAL 9005.  
Add BL after the code

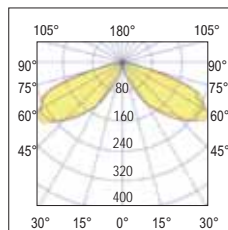

Optica **STANDARD**  
per illuminazione parchi  
**STANDARD optics recommended**  
for lighting in parks

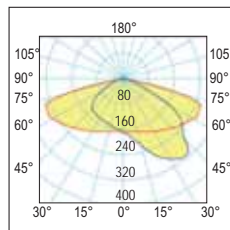

**ST/CDL**  
Optica stradale **a richiesta**  
On demand *Street optic*

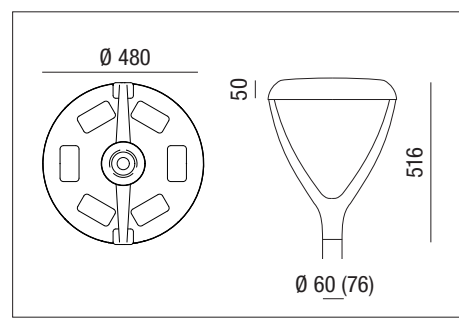

220-240 Vac

110 Vac a richiesta on demand

50/60 Hz

IP66

IK08

+50°C / -20°C

0,37 m<sup>2</sup>

850°

CRI >70



colour	W	Optic	K	nominal Im tc = 25°C	lm output	lm/W	pcs	Kg	CELL
	24	PK	3000	3.250	2.880	120	1	9,00	LAMP6ST243K
	24	PK	4000	3.250	2.880	120	1	9,00	LAMP6ST244K
	56	PK	3000	7.600	6.720	120	1	9,00	LAMP6ST563K
	56	PK	4000	7.600	6.720	120	1	9,00	LAMP6ST564K
	75	PK	2200	10.200	9.000	120	1	9,00	LAMP6ST752K
	75	PK	3000	10.200	9.000	120	1	9,00	LAMP6ST753K
	75	PK	4000	10.200	9.000	120	1	9,00	LAMP6ST754K

## LED Lampione 7



**A richiesta**  
Nero RAL 9005.  
Aggiungere BL dopo il codice  
On demand  
Black RAL 9005.  
Add BL after the code

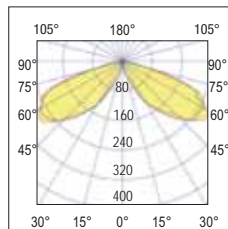

Optica **STANDARD** per illuminazione parchi  
**STANDARD optics recommended**  
for lighting in parks

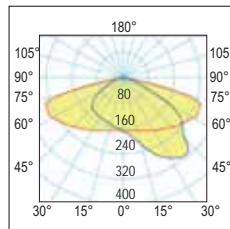

**ST/CDL**  
Optica stradale **a richiesta**  
On demand *Street optic*

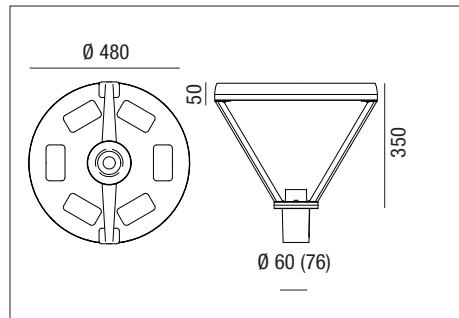

220-240 Vac

110 Vac a richiesta on demand

50/60 Hz

IP66

IK08

+50°C / -20°C

0,37 m<sup>2</sup>

850°

CRI >70



colour	W	Optic	K	nominal Im tc = 25°C	lm output	lm/W	pcs	Kg	CELL
	24	PK	3000	3.250	2.880	120	1	9,00	LAMP7ST243K
	24	PK	4000	3.250	2.880	120	1	9,00	LAMP7ST244K
	56	PK	3000	7.600	6.720	120	1	9,00	LAMP7ST563K
	56	PK	4000	7.600	6.720	120	1	9,00	LAMP7ST564K
	75	PK	2200	10.200	9.000	120	1	9,00	LAMP7ST752K
	75	PK	3000	10.200	9.000	120	1	9,00	LAMP7ST753K
	75	PK	4000	10.200	9.000	120	1	9,00	LAMP7ST754K

## LED Lampione 8 - 9



LED Lampione 8



LED Lampione 9

**Apparecchio predisposto all'installazione su palo (Vedi Pag. 102)**  
**Device designed for pole installation (See page 102)**

# LED Lampione 8



**PALO NON INCLUSO**  
(Vedi Pag. 102)  
**NOT INCLUDE POLE**  
(See Page 102)



**A richiesta**  
Nero RAL 9005.  
Aggiungere BL dopo il codice  
On demand  
Black RAL 9005.  
Add BL after the code

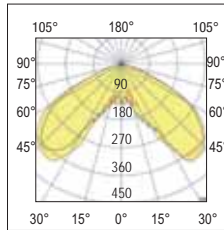

Optica **STANDARD** per illuminazione parchi  
**STANDARD** optics recommended for lighting in parks

220-240 Vac    110 a richiesta on demand Vac

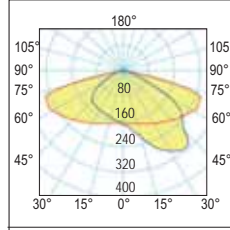

**ST/CDL**  
Optica stradale **a richiesta**  
On demand *Street optic*

50/60 Hz    IP66    IK08

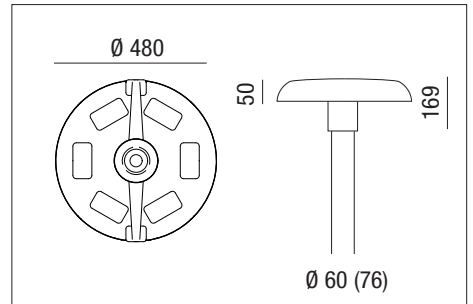

+50 C° -20    0,37 m²    850°    CRI >70    CE

colour	W	Optic	K	nominal lm tc = 25°C	lm output	lm/W	pcs	Kg	CELL
☐	24	PK	3000	3.250	2.880	120	1	9,00	LAMP8ST243K
☐	24	PK	4000	3.250	2.880	120	1	9,00	LAMP8ST244K
☐	56	PK	3000	7.600	6.720	120	1	9,00	LAMP8ST563K
☐	56	PK	4000	7.600	6.720	120	1	9,00	LAMP8ST564K
☐	75	PK	2200	10.200	9.000	120	1	9,00	LAMP8ST752K
☐	75	PK	3000	10.200	9.000	120	1	9,00	LAMP8ST753K
☐	75	PK	4000	10.200	9.000	120	1	9,00	LAMP8ST754K

# LED Lampione 9



**PALO NON INCLUSO**  
(Vedi Pag. 102)  
**NOT INCLUDE POLE**  
(See Page 102)



**A richiesta**  
Nero RAL 9005.  
Aggiungere BL dopo il codice  
On demand  
Black RAL 9005.  
Add BL after the code

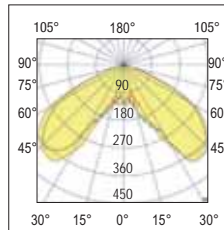

Optica **STANDARD** per illuminazione parchi  
**STANDARD** optics recommended for lighting in parks

220-240 Vac    110 a richiesta on demand Vac

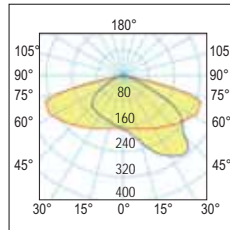

**ST/CDL**  
Optica stradale **a richiesta**  
On demand *Street optic*

50/60 Hz    IP66    IK08

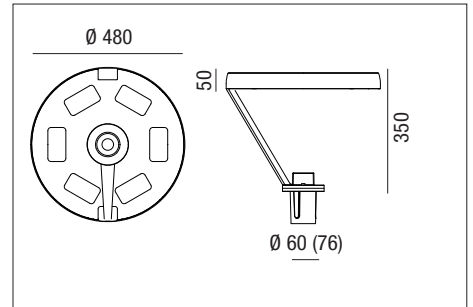

+50 C° -20    0,37 m²    850°    CRI >70    CE

colour	W	Optic	K	nominal lm tc = 25°C	lm output	lm/W	pcs	Kg	CELL
☐	24	PK	3000	3.250	2.880	120	1	9,00	LAMP9ST243K
☐	24	PK	4000	3.250	2.880	120	1	9,00	LAMP9ST244K
☐	56	PK	3000	7.600	6.720	120	1	9,00	LAMP9ST563K
☐	56	PK	4000	7.600	6.720	120	1	9,00	LAMP9ST564K
☐	75	PK	2200	10.200	9.000	120	1	9,00	LAMP9ST752K
☐	75	PK	3000	10.200	9.000	120	1	9,00	LAMP9ST753K
☐	75	PK	4000	10.200	9.000	120	1	9,00	LAMP9ST754K



## LED Lampione 10 - 12



LED Lampione 10



LED Lampione 12



Apparecchio predisposto all'installazione  
su palo (Vedi Pag. 102)  
Device designed for pole installation  
(See page 102)

## LED Lampione 10



**A richiesta**  
Nero RAL 9005.  
Aggiungere BL dopo il codice  
On demand  
Black RAL 9005.  
Add BL after the code

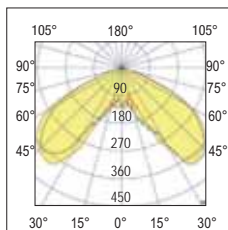

Ottica STANDARD per illuminazione parchi  
STANDARD optics recommended for lighting in parks

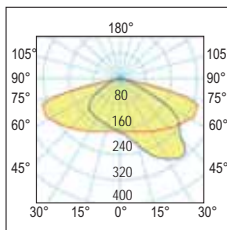

ST/CDL  
Ottica stradale a richiesta  
On demand Street optic

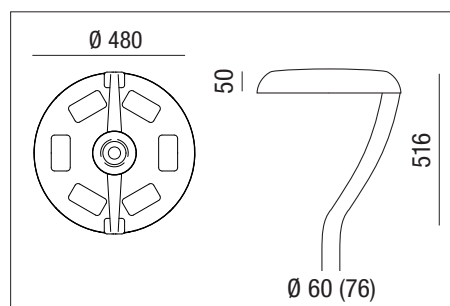

220-240 Vac

110 Vac a richiesta on demand

50/60 Hz

IP66

IK08

+50°C  
-20°C

0,37 m<sup>2</sup>

850°

CRI >70

CE

DRIVER INCLUDED



colour	W	Optic	K	nominal lm tc = 25°C	lm output	lm/W	pcs	Kg	CELL
G	24	PK	3000	3.250	2.880	120	1	9,00	LAMP10ST243K
G	24	PK	4000	3.250	2.880	120	1	9,00	LAMP10ST244K
G	56	PK	3000	7.600	6.720	120	1	9,00	LAMP10ST563K
G	56	PK	4000	7.600	6.720	120	1	9,00	LAMP10ST564K
G	75	PK	2200	10.200	9.000	120	1	9,00	LAMP10ST752K
G	75	PK	3000	10.200	9.000	120	1	9,00	LAMP10ST753K
G	75	PK	4000	10.200	9.000	120	1	9,00	LAMP10ST754K

## LED Lampione 12



**A richiesta**  
Nero RAL 9005.  
Aggiungere BL dopo il codice  
On demand  
Black RAL 9005.  
Add BL after the code

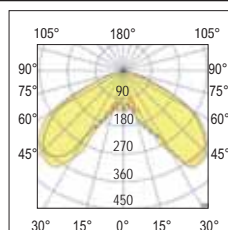

Ottica STANDARD per illuminazione parchi  
STANDARD optics recommended for lighting in parks

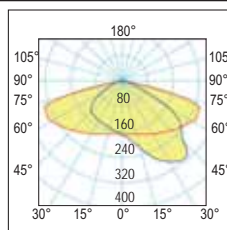

ST/CDL  
Ottica stradale a richiesta  
On demand Street optic

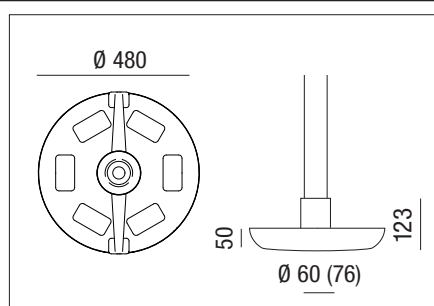

220-240 Vac

110 Vac a richiesta on demand

50/60 Hz

IP66

IK08

+50°C  
-20°C

0,37 m<sup>2</sup>

850°

CRI >70

CE

DRIVER INCLUDED



colour	W	Optic	K	nominal lm tc = 25°C	lm output	lm/W	pcs	Kg	CELL
G	24	PK	3000	3.250	2.880	120	1	9,00	LAMP12ST243K
G	24	PK	4000	3.250	2.880	120	1	9,00	LAMP12ST244K
G	56	PK	3000	7.600	6.720	120	1	9,00	LAMP12ST563K
G	56	PK	4000	7.600	6.720	120	1	9,00	LAMP12ST564K
G	75	PK	2200	10.200	9.000	120	1	9,00	LAMP12ST752K
G	75	PK	3000	10.200	9.000	120	1	9,00	LAMP12ST753K
G	75	PK	4000	10.200	9.000	120	1	9,00	LAMP12ST754K



Predisposizione Zhaga Socket  
Zhaga Socket preparation

**A richiesta - On demand**  
Sistema wireless per gestire centralmente l'illuminazione pubblica.  
Wireless system to centrally manage public lighting.

**Accessori non inclusi Not included accessories**



Code: 210001465

Adattatore palo da Ø 60mm a Ø 76mm.  
Necessario per l'installazione su palo  
Up Ø 60mm to 76mm adapter pole.  
Required for installation on the pole

# Pali conici dritti - Straight conical poles

## CICLO DI FABBRICAZIONE

### Spianatura e taglio della lamiera

Il rotolo di lamiera viene spianato mediante un impianto combinato “raddrizzatrice-spianatrice”, con rifilatura ai bordi per ottenere le adeguate tolleranze dimensionali. Il foglio di lamiera viene successivamente tagliato da una cesoia longitudinale ottenendo due trapezi uguali.

### Formatura tronco-conica

Il trapezio viene sottoposto a formatura a tronco di cono utilizzando presse piegatrici asservite da manipolatori automatici a controllo numerico.

### Saldatura

I lembi del tronco di cono vengono uniti longitudinalmente mediante procedimenti di saldatura automatici e manuali. Le saldature vengono effettuate nel rispetto di specifiche tecniche di lavorazione (WPS) conformi alle norme UNI EN ISO 15609-2 ed adottando procedimenti qualificati (WPAR) conformi alle norme UNI EN ISO 15614-1. Tutti gli addetti alla saldatura sono qualificati con patentino secondo le norme UNI EN ISO 14732 e UNI EN ISO 9606.

### Finitura

Conclusa la fase di saldatura il palo viene sottoposto a specifiche lavorazioni alla base (es. asole) ed in punta (es. calibratura).

### Collaudi

Ogni fase di lavorazione è sottoposta a controllo costante da parte degli addetti che operano sotto la supervisione del Responsabile dell'Ufficio Controllo Qualità.

## MANUFACTURING CYCLE

### Sheet metal straightening and cutting

The sheet metal roll is straightened using a combined “straightening-straightening” system, with trimming at the edges to obtain the appropriate dimensional tolerances. The sheet metal is then cut by a longitudinal shear to obtain two equal trapeziums.

### Truncated cone forming

The trapezium is subjected to truncated cone forming using press brakes served by automatic numerically controlled manipulators.

### Welding

The edges of the truncated cone are joined longitudinally using automatic and manual welding processes. The welds are carried out in compliance with specific processing techniques (WPS) compliant with the UNI EN ISO 15609-2 standards and adopting qualified procedures (WPAR) compliant with the UNI EN ISO 15614-1 standards. All welding personnel are qualified with a license according to UNI EN ISO 14732 and UNI EN ISO 9606 standards.

### Finishing

Once the welding phase is completed, the pole is subjected to specific processes at the base (e.g. slots) and at the tip (e.g. calibration).





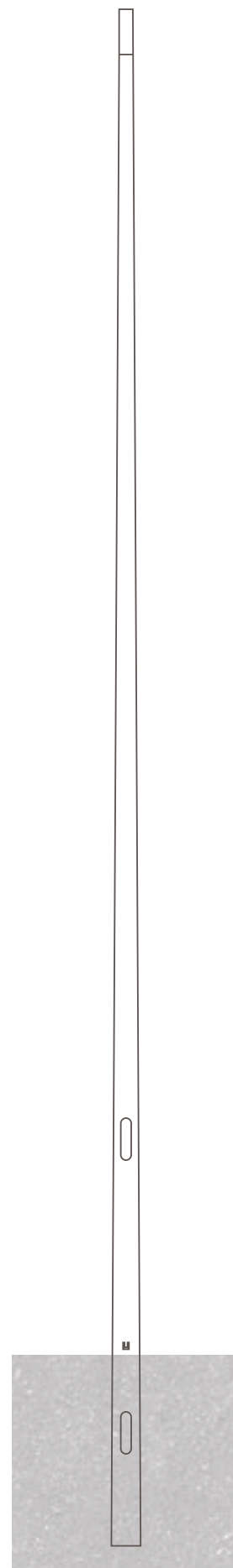





### Testing

Each processing phase is subject to constant monitoring by personnel who operate under the supervision of the Quality Control Office Manager.















## Pali conici dritti - Straight conical poles

Code											
3500/3	3.000	500	3	60x95	21	0,85	38x132	1500	350	900x800	200x500
4000/3	3.500	500	3	60x100	25	1,00	38x132	1500	350	900x800	200x500
4500/3	4.000	500	3	60x105	28	1,17	38x132	1500	350	950x800	250x500
5000/3	4.500	500	3	60x110	32	1,33	38x132	1500	350	950x800	250x500
5500/3	5.000	500	3	60x115	37	1,51	38x132	1500	350	950x800	250x500
6000/3	5.500	800	3	60x120	42	1,70	38x132	1500	350	1050x800	300x500
6800/3	6.000	800	3	60x128	48	2,01	46x186	1800	600	1000x1100	300x800
6800/4	6.000	800	4	60x128	63	2,01	46x186	1800	600	1050x1100	300x800
7800/3	7.000	800	3	60x138	58	2,42	46x186	1800	600	1000x1100	300x800
7800/4	7.000	800	4	60x138	77	2,42	46x186	1800	600	1000x1100	300x800
8800/3	8.000	800	3	60x148	69	2,87	46x186	1800	600	1000x1100	300x800
8800/4	8.000	800	4	60x148	91	2,87	46x186	1800	600	1150x1100	300x800

**Acciaio S235JR - UNI EN10025 - Steel S235JR - UNI EN10025**

**A richiesta pali di altezze superiori - Poles of higher heights available on request**

Legenda simboli - Symbols legend	
	Altezza palo fuori terra (mm) - Pole height above ground (mm)
	Interramento palo (mm) - Pole burial (mm)
	Spessore (mm) - Thickness (mm)
	Diametro di sommità e base (mm) - Diameter of top and base (mm)
	Peso totale (Kg) - Total weight (Kg)
	Superficie verniciatura (m2) - Painting surface (m2)
	Asola di entrata per cavi e morsettiera (mmxmm) - Cable entry slot and terminal block (mmxmm)
	Posizionamento asola entrata per la morsettiera da base palo (mm) Positioning of the entry slot for the terminal block from the base of the pole (mm)
	Posizionamento asola entrata per per i cavi da base palo (mm) Positioning of entry slot for cables from pole base (mm)
	Dimensioni del plinto monoblocco a base quadrata LxH (mm) Dimensions of the square-based monobloc plinth LxH (mm)
	Foro nel plinto di formazione per innesto del palo ØxH (mm) Hole in the training plinth for pole insertion ØxH (mm)



## DYNA

Il settaggio del FLUSSO LUMINOSO avviene con programmazione della corrente di pilotaggio. Tale programmazione va richiesta in sede, durante la fase d'ordine / progetto.  
 The LUMINOUS FLUX setting is done by programming the driving current.  
 This programming must be requested on site, during the order / project phase

A richiesta - On demand



Vedi Pag. VI  
 See page VI

Gamma di apparecchi a LED per illuminazione di aree urbane. Ideale per l'illuminazione di strade, vicoli, parcheggi, aree residenziali. I prodotti sono stati costruiti conformemente alle normative vigenti, anche facendo riferimento alle leggi contro l'inquinamento luminoso.

**Attacco palo:** in alluminio pressofuso idoneo per pali Ø min 45mm Ø max 60mm. Orientabile da  $\pm 0$  a  $\pm 20^\circ$  o a "frusta".

**Corpo:** in alluminio pressofuso UNI EN 1706.

**Verniciatura:** il ciclo di verniciatura standard a liquido, ad immersione, è composto da diverse fasi.

Una prima fase di pretrattamento superficiale del metallo, poi una verniciatura in cataforesi episodica resistente alla corrosione e alle nebbie saline, poi una mano finale di liquido bicomponente acrilico, stabilizzato ai raggi UV.

Per ambienti marini (fronte mare) conforme alla Norma UNI EN ISO 9227 (circa 1.000 ore)

**Colore:** Grigio RAL 9007 (a richiesta Nero RAL 9005)

**Ottica:** stradale diffondente (altre ottiche a richiesta)

**Guarnizione:** in poliuretano a celle chiuse dalle rilevanti prestazioni meccaniche ed elastiche

**Sorgente:** LED LUMILEDS 5050

Mantenimento del flusso luminoso 90% - L90B10 > 100.000h per il 90% dei LED.

**Temperatura di colore:** 3000K / 4000K (altre temperature di colore a richiesta);

**Cablaggio:** con cavo di alimentazione lunghezza 30cm

**Power factor:**  $\geq 0,95$

**A richiesta protezione alle sovratensioni:**

modo differenziale 6kV (L-N)

modo comune 8kV (L-GND, N-GND, L&N-GND)

**Norme di riferimento:** IEC 61000-4-5; EN60598-1; EN60598-2-1; EN62471; EN62031; EN60598-2-5; EN61547

*Range of LED luminaires to light up urban areas. Suitable for streets, narrow roads, car parks and residential areas lighting. The products are developed in compliance with norms currently in force, also referring to legislation regarding light pollution.*

*Pole attachment: in die-cast aluminum suitable for min Ø 45mm max 60mm poles can be pivoted  $\pm 0$  to  $\pm 20^\circ$  or side mounting.*

*Body: made by UNI EN 1706 die-cast aluminum*

*Painting: the standard liquid painting cycle, by immersion, is made up of different phases.*

*A first phase of surface pre-treatment of the metal, then an episodic cathoresis painting resistant to corrosion and salt spray, then a final coat of two-component acrylic liquid, stabilized against UV rays.*

*For marine environments (seafront) compliant with the UNI EN ISO 9227 standard (approximately 1,000 hours)*

*Colour: RAL 9007 Grey color (on demand RAL 9005 Black color)*

*Optic: stree diffused (other optics on request)*

*Gasket: made by closed cell polyurethane with high mechanical and elastic performance*

*Light source: LED LUMILEDS*

*Maintenance of minimum luminous flux - L90B10 > 100.000h for 90% of LED.*

*Color temperature: 3000K;*

*Source: LUMILEDS 5050;*

*Wiring: with supply cable, length 30cm*

*Power factor:  $\geq 0,95$*

*On demand surge protection:*

*differential mode 6kV (L-N)*

*standard mode 8kV (L-GND, N-GND, L&N-GND).*

*Standard reference: IEC 61000-4-5; EN60598-1; EN60598-2-1; EN62471; EN62031; EN60598-2-5; EN61547*

100-240 Vac    50/60 Hz    IP66    IK09    CRI > 70    +40°C / -20°C       CE    850°         

**Driver included**

**RG0**

**LOW FLICKER**

**17 pending**



**A richiesta**  
Nero RAL 9005.  
Aggiungere BL dopo il codice  
**On demand**  
Black RAL 9005.  
Add BL after the code

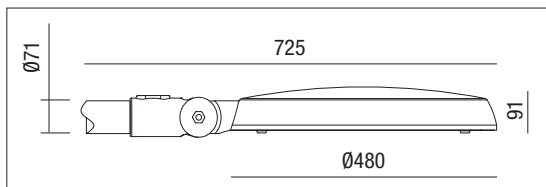

colour	W	Optic	K	nominal lm tc = 25°C	lm output	lm/W	pcs	Kg	CELL
G	50	ST	2700	8.200	7.250	145	1	5,00	31545-27
G	75	ST	2700	12.300	10.900	145	1	5,00	31575-27
G	20	ST	4000	3.300	2.900	145	1	5,00	31525
G	30	ST	4000	4.900	4.350	145	1	5,00	31530
G	40	ST	4000	6.600	5.800	145	1	5,00	31540
G	50	ST	4000	8.200	7.250	145	1	5,00	31545
G	60	ST	4000	9.800	8.700	145	1	5,00	31560
G	75	ST	4000	12.300	10.900	145	1	5,00	31575
G	20	ST	3000	3.300	2.900	145	1	5,00	31525-3K
G	30	ST	3000	4.900	4.350	145	1	5,00	31530-3K
G	40	ST	3000	6.600	5.800	145	1	5,00	31540-3K
G	50	ST	3000	8.200	7.250	145	1	5,00	31545-3K
G	60	ST	3000	9.800	8.700	145	1	5,00	31560-3K
G	75	ST	3000	12.300	10.900	145	1	5,00	31575-3K
G	20	ST	4000	3.300	2.900	145	1	5,00	31525-DA
G	30	ST	4000	4.900	4.350	145	1	5,00	31530-DA
G	40	ST	4000	6.600	5.800	145	1	5,00	31540-DA
G	50	ST	4000	8.200	7.250	145	1	5,00	31545-DA
G	60	ST	4000	9.800	8.700	145	1	5,00	31560-DA
G	75	ST	4000	12.300	10.900	145	1	5,00	31575-DA
G	20	ST	3000	3.300	2.900	145	1	5,00	31525-DA-3K
G	30	ST	3000	4.900	4.350	145	1	5,00	31530-DA-3K
G	40	ST	3000	6.600	5.800	145	1	5,00	31540-DA-3K
G	50	ST	3000	8.200	7.250	145	1	5,00	31545-DA-3K
G	60	ST	3000	9.800	8.700	145	1	5,00	31560-DA-3K
G	75	ST	3000	12.300	10.900	145	1	5,00	31575-DA-3K
G	20	ST	4000	3.300	2.900	145	1	5,00	31525-DY
G	30	ST	4000	4.900	4.350	145	1	5,00	31530-DY
G	40	ST	4000	6.600	5.800	145	1	5,00	31540-DY
G	50	ST	4000	8.200	7.250	145	1	5,00	31545-DY
G	60	ST	4000	9.800	8.700	145	1	5,00	31560-DY
G	75	ST	4000	12.300	10.900	145	1	5,00	31575-DY
G	20	ST	3000	3.300	2.900	145	1	5,00	31525-DY-3K
G	30	ST	3000	4.900	4.350	145	1	5,00	31530-DY-3K
G	40	ST	3000	6.600	5.800	145	1	5,00	31540-DY-3K
G	50	ST	3000	8.200	7.250	145	1	5,00	31545-DY-3K
G	60	ST	3000	9.800	8.700	145	1	5,00	31560-DY-3K
G	75	ST	3000	12.300	10.900	145	1	5,00	31575-DY-3K

DALI 2

DALI 2

DALI 2

DALI 2

DALI 2

DALI 2

DALI 2

DALI 2

DALI 2

DALI 2

DALI 2

DALI 2

DYNA

DYNA

DYNA

DYNA

DYNA

DYNA

DYNA

DYNA

DYNA

DYNA

DYNA

DYNA

Street furniture





Connettore rapido IP68 incluso  
IP68 quick connector included



Connettore rapido IP68 incluso  
IP68 quick connector included

# LED Gardena

Accessori non inclusi - *Not included accessories*



Street furniture



**Code:** 10001465

Adattatore palo da Ø 60mm a Ø 76mm.  
Up Ø 60mm to Ø 76mm adapter pole.



**Code:** 220001236

Braccio a parete  
Wall bracket

## ZHAGA SOCKET



**Code:** 488787561

Connettore max 30Vdc - max 1,5A  
Connector max 30Vdc - max 1,5A

**Code:** 488787581

Tappo IP66  
Cap connector IP66

## Ottica - Optic

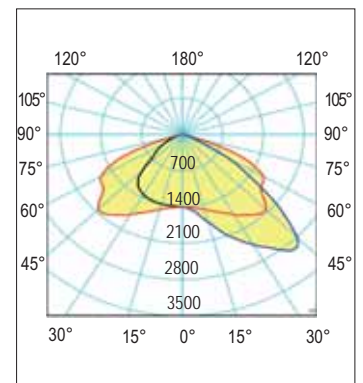

**ST/CDL**

Stradale - *Street optic*



# LED Minisempione - LED Sempione - LED Maxisempione - LED Megasempione



Street furniture

La certificazione fotometrica dei nostri apparecchi viene sempre effettuata da un istituto esterno. Efficienza luminosa e "lm Output" sono quindi il risultato di tale istituto.

*The photometric certification of our appliances is always carried out by an external institute. Luminous efficiency and "lm Output" are therefore the result of this institute.*

A richiesta - On demand

1-10Vdc



DYNA

Wireless

Vedi Pag. VI - See page VI

Gamma di apparecchi a LED per illuminazione di aree urbane. Ideale per l'illuminazione di strade, parcheggi, aree residenziali.

**Installazione:** attacco palo in alluminio pressofuso idoneo per pali di diametro min. 55mm - max. 65mm, orientabile da  $\pm 0$  a  $\pm 20^\circ$  o a "frusta".

**Corpo e telaio:** in alluminio pressofuso UNI EN 1706 verniciato con polvere termoindurente poliesteri.

**Imbocco a palo:** in alluminio pressofuso UNI EN 1706, verniciato con polvere termoindurente poliesteri, con goniometro graduato per un corretto puntamento del fascio luminoso.

**Verniciatura:** di tipo poliesteri eseguita a polvere, resistente agli agenti atmosferici e alla corrosione e garantita per 1.200 ore in nebbia salina (ISO 9227). Colore Grigio RAL 9007 (a richiesta RAL 1013).

**Schermo:** vetro temperato di spessore 4mm resistente agli shock termici e agli urti.

**Ottica:** In PMMA con resistenza alle alte temperature, agli shock termici e agli urti.

**Sorgente:** LED LUMILEDS 5050

Mantenimento del flusso luminoso minimo al 90% - L90B10 > 100.000h per il 90% dei LED.

**Temperatura di colore:** 4000K; altre temperature di colore a richiesta (2200K - 2700K - 3000K - 5000K - Consegna 60 giorni).

**Protezione alle sovratensioni inclusa:**

Modo differenziale 6kV (L-N)

Modo comune 8kV (L-GND, N-GND, L&N-GND)

**A richiesta:** versione con protezione maggiorata (10kV) contro gli impulsi aggiungendo il cod. RO0640/N.

**Driver:** incorporato   
 Fattore di potenza  $\geq 0,98$ .

**Norme di riferimento:** IEC 61000-4-5; EN60598-1; EN60598-2-1; EN62471; EN62031; EN60598-2-3; EN61547

*Range of LED luminaires to light up urban areas. Suitable for roads, car parks and residential areas lighting.*

*Installation: mast top mounting in die cast aluminium suitable for poles with a diameter of min. 55mm - max. 65mm, that can be pivoted  $\pm 0$  to  $\pm 20^\circ$  or side mounting*

*Housing and frame: made by UNI EN 1706 die-cast aluminium, coated with polyester thermoset powder.*

*Pole entrance: made by UNI EN 1706 die-cast aluminium, coated with polyester thermoset powder, with graduated goniometer to allow the correct orientation of light beam.*

*Coating: coated with powdered polyester, resistant to atmospheric agents, corrosion and guaranteed for 1.200 hours in saline mist (ISO 9227).*

*Grey RAL 9007 color (on demand RAL 1013).*

*Shield: tempered glass with 4mm thickness resistant to thermal shocks and collisions.*

*Optic: PMMA optic with high temperature resistance, thermal shock and impact resistance*

*Light source: LED LUMILEDS 5050*

*Maintenance of minimum luminous flux to 90% - L90B10 > 100.000h for 90% of LED.*

*Color temperature: 4000K; other color temperatures available on demand (2200K - 2700K - 3000K - 5000K. Delivery time: 60 days)*

*Protection against overvoltages included:*

*Differential mode 6kV (L-N)*

*Standard mode 8kV (L - GND, N-GND, L&N-GND).*

*On demand: this version with greater protection (10kV) with code RO0640/N.*

*Driver: included   
 Power factor  $\geq 0,98$*

*Standard reference: IEC 61000-4-5; EN60598-1; EN60598-2-1; EN62471; EN62031; EN60598-2-3; EN61547*



# LED Minisempione - LED Sempione - LED Maxisempione - LED Megasempione

## Durata e Aspettativa di vita del LED

Contrariamente alle lampade tradizionali, il LED non si spegne improvvisamente all'esaurimento della sua vita utile, ma diminuisce, in tempi molto lunghi, il flusso iniziale fino al suo completo esaurimento. Il LED non si rompe (se non per difettosità), ma subisce un decadimento continuo dell'efficienza. La durata di vita utile indica la percentuale di decadimento del flusso luminoso (L) riferita ad un numero di ore utili di funzionamento. L'aspettativa di Vita (B) indica la percentuale di componenti che, raggiunte le ore utili di funzionamento, non mantengono le caratteristiche di flusso luminoso dichiarate. Per esempio un LED dichiarato L80/B10=100.000 ore, indica che al raggiungimento delle 100.000 ore il 90% (B10) dei moduli LED fornisce ancora l'80% del flusso luminoso iniziale (L80)

## LED service life expectancy

Unlike traditional lamps, they do not tend to go out suddenly at the end of their useful life, but slowly decrease in flux until they expire. The LED does not break (unless it is defective), but declines gradually in performance. The drop in LED flux, defined as the useful life, is represented by the acronym L80 (see graph), which means flux at 80%. Value "B" followed by a value between 10 and 50 indicates the quality of the component being used, defining the percentage of LED that does not maintain the declared characteristics when the 100,000 hours have elapsed.

LED: mantenimento del flusso luminoso - TM21 (compreso fine del ciclo di vita) LED: maintenance of the lighting flux - TM21 (including end of life cycle)						
	n° LED	W	L80B10 @ta: +25°C	L80B10 @ta: +45°C	L90B10 @ta: +25°C	L90B10 @ta: +45°C
LED Minisempione	128	50	> 100.000 h	> 100.000 h	70.000 h	50.000 h
	128	75				
LED Sempione	192	95	> 100.000 h	> 100.000 h	70.000 h	50.000 h
	192	120				
LED Maxisempione	320	160	> 100.000 h	> 100.000 h	70.000 h	50.000 h
	80	210				
LED Megasempione	144	250	> 100.000 h	> 100.000 h	70.000 h	50.000 h
	144	300				

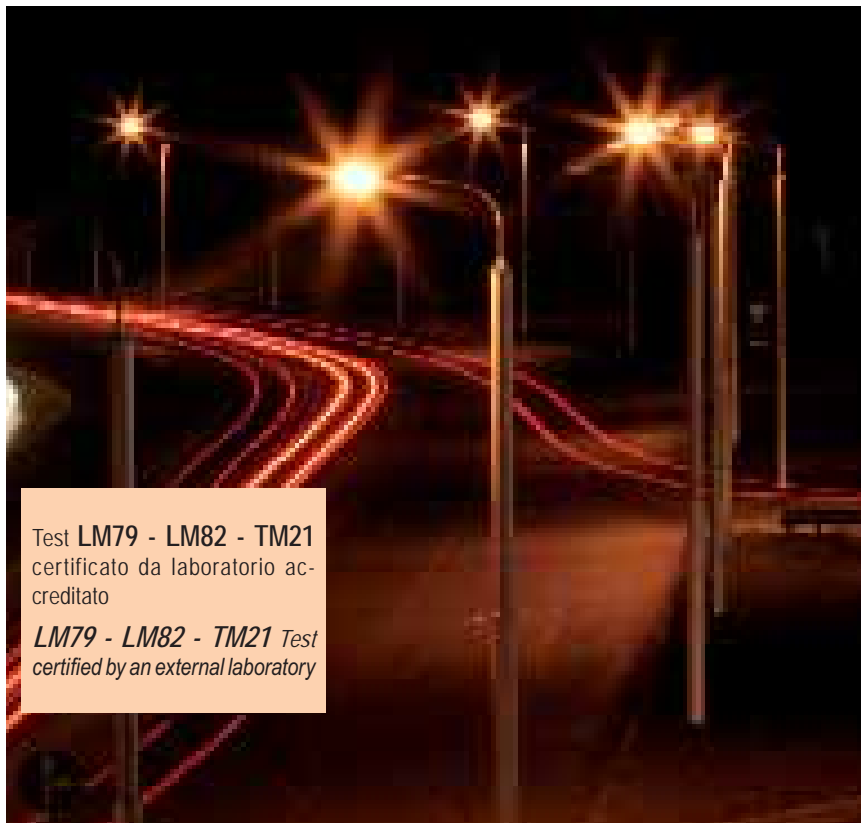
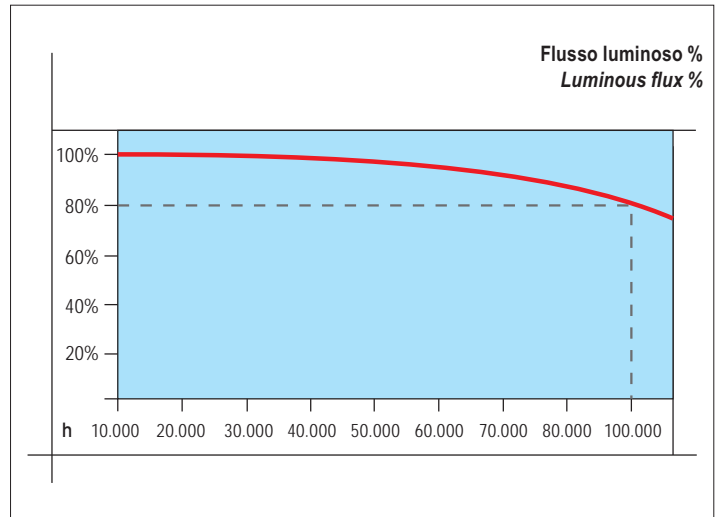

Test LM79 - LM82 - TM21  
certificato da laboratorio accreditato

LM79 - LM82 - TM21 Test  
certified by an external laboratory



### ST/CDL

**ST1,1** - l = 12h / d = 1,1  
Intensity class: G\*3

**ST0,9** - l = 15h / d = 0,9 / h <= 16  
Intensity class: G\*3

**ST1,3** - l = 10h / d = 1,3  
Intensity class: G\*3

Classi di intensità CEN (classificazione provvisoria) e valore stimato del relativo ULOR massimo - CEN intensity classes (provisional classification) and estimated value of its maximum ULOR

Class	70truept o	80truept o	90truept o	95truept o	
Prelim.					
G1		200 cd/klm	50 cd/klm		~ 31%
G2		150 cd/klm	30 cd/klm		~ 18,8%
G3		100 cd/klm	20 cd/klm		~ 12,6%
G4	500 cd/klm	100 cd/klm	10 cd/klm	0 cd/klm	~ 0,55%
G5	350 cd/klm	100 cd/klm	10 cd/klm	0 cd/klm	~ 0,55%
G6	350 cd/klm	100 cd/klm	0 cd/klm	0 cd/klm	0%

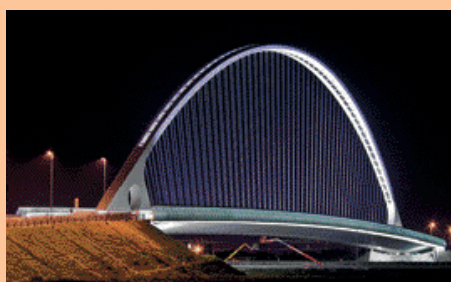

I modelli della serie LED Sempione sono conformi alle prove di vibrazione, secondo la Norma EN 60598-1 certificata da Ente esterno: Illuminazione stradale - Vibrazione degli apparecchi di illuminazione

The models of the LED Sempione series comply with vibration tests, according to the EN 60598-1 standard certified by the external body: Street lighting - Vibration of lighting fixtures







# LED Minisempione - LED Sempione - LED Maxisempione - LED Megasempione

## Dettagli Details



**Completo di dispositivo anticondensa.**  
Pressacavo con valvola di compensazione e riciclo dell'aria  
*Complete with anti-condensate device.*  
Cable gland with valve for compensation and circulation of air.



**Completo di sezionatore di linea in doppio isolamento** che interrompe l'alimentazione elettrica all'apertura del body.  
*Complete with line disconnector in double insulation that interrupts the power supply when the body is opened.*



Street furniture



**Completo di connettore IP68** per una rapida installazione  
*Complete with IP68 connector for quick installation*



**A richiesta:** verniciatura resistente a 2.000 ore di esposizione alla nebbia salina in accordo alla norma ISO 9227 certificato da Ente esterno.

*On request: painting resistant to 2,000 hours of exposure to salt spray in accordance with ISO 9227 certified by an external body.*



**Ottiche:** realizzate in PMMA resistenti ai raggi UV

*Optics: made in PMMA resistant to UV radiation*

## Accessori NON inclusi - Accessories NOT included



**Code: 220001236**  
Braccio a parete  
*Wall bracket*

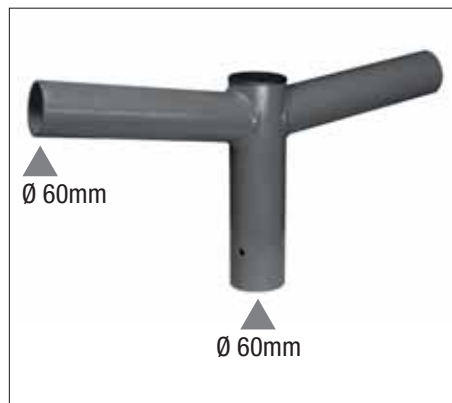

**Cod. 802020.0101**  
Braccio 2X - 2X bracket



**ZHAGA SOCKET**  
- Connettore max 30Vdc - max 1,5A  
Connector max 30Vdc - max 1,5A  
**Code: 488787561**  
- Tappo IP66 - Cap connector IP66  
**Code: 488787581**

**Gestione del punto luce per un ulteriore risparmio di energia (richiedere preventivo) - Management of the lighting point for further energy savings (Request a quotation)**

Regolazione 1±10V 1±10V control	Mezzanotte virtuale Virtual midnight	Zhaga Socket	Telegestione sistema Wi-Fi (da concordare) Wi-Fi system remote management (to be agreed)
Possibilità di regolazione 10% - 100% con sistema 1±10V Possibility of adjustment 10% - 100% with 1-10V system	Sistema con riduzione automatica del flusso System with automatic flux reduction	Predisposizione sul corpo dell'apparecchio. Ideale per la gestione dell'illuminazione autonoma locale tramite sensori o da remoto. For installation on the body of the appliance. Ideal for autonomous management of the lighting, either locally with sensors or remotely	Sistema di controllo, gestione consumi e diagnosi dell'impianto con tecnologia Wi-Fi Control system, consumption management and diagnosis of the system with Wi-Fi technology

**DYNA control - Mezzanotte virtuale - Virtual midnight**

**DYNA**

Il settaggio del FLUSSO LUMINOSO avviene con programmazione della corrente di pilotaggio. Tale programmazione va richiesta in sede, durante la fase d'ordine / progetto.  
The LUMINOUS FLUX setting is done by programming the driving current. This programming must be requested on site, during the order / project phase

DYNA CONTROL è un sistema automatico di controllo del flusso luminoso delle lampade. Il sistema entra in funzione alla prima accensione calcolando per 3 giorni i tempi di accensione, il quarto giorno il sistema in modo autonomo, calcola la mezzanotte virtuale eseguendo una regolazione del flusso regolando la lampada come indicato sullo schema di Fig. 1; per i primi tre giorni, quindi, il sistema manterrà le lampade accese al 100%, nel tempo di accensione dell'impianto, il quarto giorno entrerà in funzione il sistema DYNA CONTROL gestendo in modo autonomo il flusso luminoso garantendo così un notevole risparmio energetico.

Accensioni inferiori ad 1 ora (es. manutenzione) verranno ignorate ed il sistema non entra in funzione, per accensioni da 1 a 4 ore (es. anomalia impianto) o superiori alle 23 ore (es. impianto sempre acceso), il sistema resetta il timer quindi ricomincerà a contare per i primi 3 giorni e successivamente riprenderà il funzionamento automatico.

DYNA CONTROL is an automatic control system for the luminous flux of the lamps. The system comes into operation at the first start-up by calculating the ignition times for 3 days, on the fourth day the system autonomously calculates the virtual midnight by adjusting the flow by adjusting the lamp as indicated in the diagram in Fig. 1; for the first three days, therefore, the system will keep the lamps on at 100%, during the system start-up time, on the fourth day the DYNA CONTROL system will come into operation, independently managing the luminous flux thus ensuring significant energy savings.

Switch-ons of less than 1 hour (e.g. maintenance) will be ignored and the system does not start up, for switch-ons from 1 to 4 hours (e.g. system anomaly) or longer than 23 hours (e.g. system always on), the system resets the timer will then start counting again for the first 3 days and will then resume automatic operation.

**Fig. 1 - Esempio applicativo 2 steps  
Application example 2 steps**

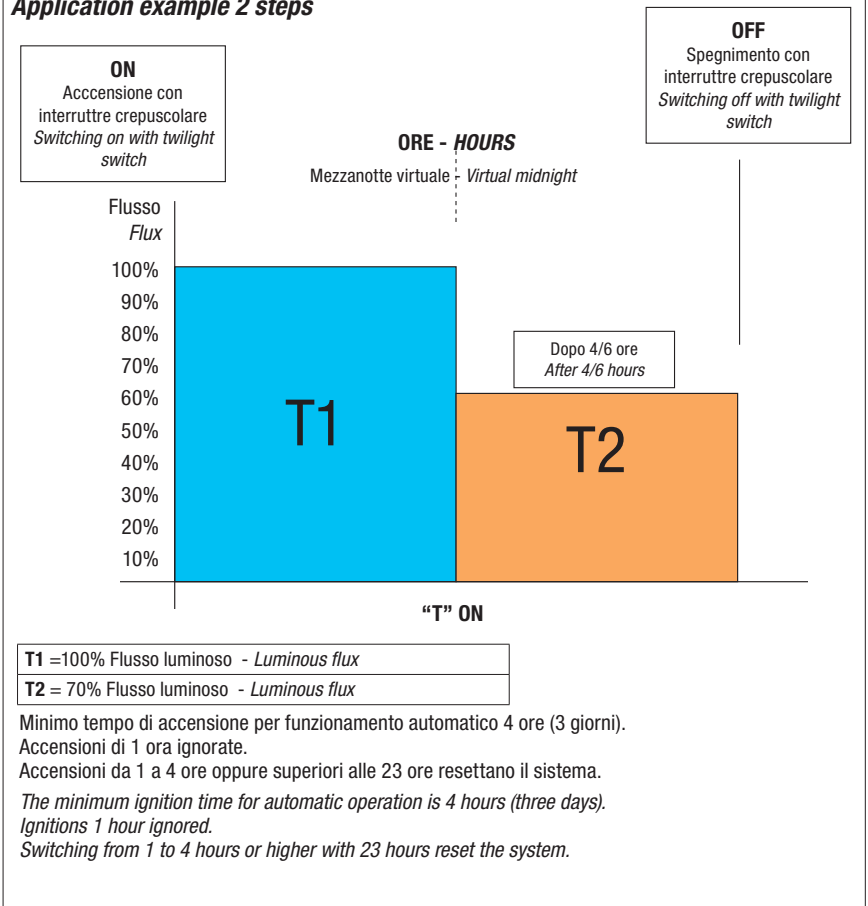

**CLO - Constant Light Output**

Tutte le fonti di luce (anche i LED) hanno una riduzione della produzione di luce nel corso del tempo. Per garantire il minimo richiesto di livelli di luce in un impianto, la maggior parte dei progetti di illuminazione sono calcolate in base al livello di luce alla fine della vita utile della lampada (di norma il punto L70: 70% dei Lumen iniziali). Ciò significa che il sistema consuma più potenza del necessario, sprecando in media 15% di energia durante la sua vita (Fig. A).

L'emissione luminosa funzionalità costante (CLO) compensa questa perdita di luce, in modo che i LED siano in grado di fornire sempre il livello di luce necessaria.

L'alimentatore può essere programmato per erogare corrente costante ad un livello ridotto per un nuovo apparecchio, ed aumentare gradualmente compensando il decadimento del flusso luminoso, Ciò influisce positivamente sulla vita della sorgente luminosa, sul risparmio energetico, prolungando la durata del sistema.

La regolazione della potenza erogata viene fatta in base al contatore delle ore di esercizio. Ad intervalli di tempo di 4.000 ore, il sistema incrementa la corrente del corrispondente valore di decadimento del flusso luminoso indicato dai costruttori della sorgente luminosa. In questo modo il flusso luminoso dell'apparecchio rimane costante per tutta la sua vita.

All light sources (including LEDs) produce less light over time. In order to guarantee the minimum required levels of light of a system, most lighting projects are planned taking into account the level of light at the end of the useful life of the lamp (normally point L70: 70% of initial lumen output). This means that the system consumes more power than necessary, wasting on average 15% of energy throughout its life (Fig. A).

The constant lumen output (CLO) compensates for this loss of light to ensure that the LEDs supply the required level of light at all times.

The power supply unit can be programmed to supply direct current at a reduced level for a new appliance, and to gradually increase this to compensate for the decline in luminous flux. This positively increases the lifespan of the light source and of the system, while ensuring energy savings.

The supply of power is adapted according to the operating hours counter. After every 4,000 hours, the system increases the current in proportion to the decrease in the luminous flux indicated by the manufacturers of the light source. In this way, the luminous flux of the appliance remains constant during its entire life-span.

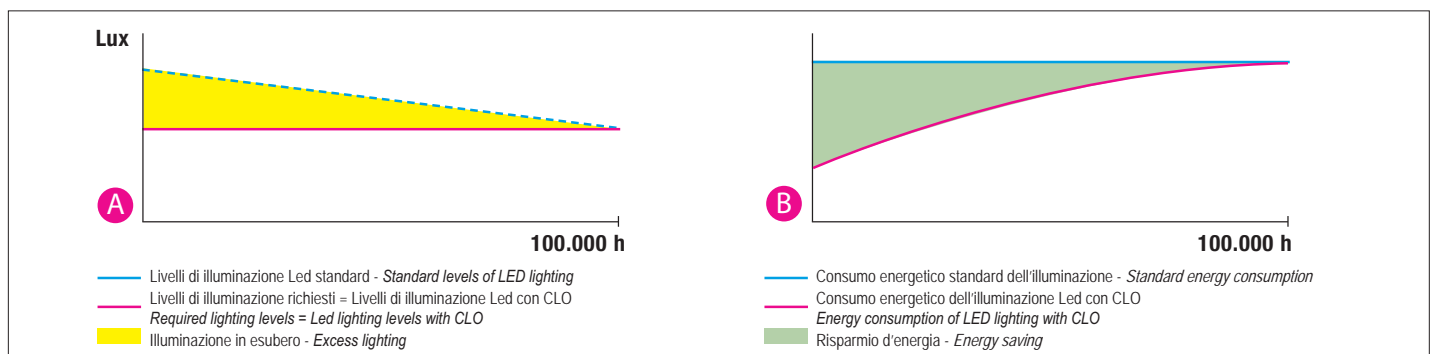

Street furniture

# Smart City

## Sistema di comunicazione Wireless

**Possibilità di coimplementazione di diverse tecnologie**  
**Programmazione e controllo da remoto mediante gateway in loco**  
**Monitoraggio in tempo reale dello stato del sistema e raccolta dati**  
**Idoneità al relamping per il risparmio energetico**  
**Ideale per applicazioni commerciali, industriali ed ambienti esterni**

Sistema estremamente efficiente, che combina soluzioni tecnologiche di prima qualità per il telecontrollo di luci e di oggetti IoT. Il sistema può monitorare, controllare e gestire le installazioni luminose, dalla singola lampada al network nel suo insieme.

Il sistema permette di coprire vaste aree e lo rende estremamente versatile in termini di compatibilità con una pluralità di dispositivi, è pensato per fornire soluzioni ad hoc sulla base delle necessità del singolo Cliente, copre una vasta gamma di applicazioni, che spaziano dalle aree commerciali agli edifici, dai capannoni industriali ai giardini pubblici, a città, strade e tunnel.

Impiegando diversi componenti è possibile gestire la luce a 360°, effettuare misurazioni di specifici parametri ambientali come l'inquinamento atmosferico, monitorare lo stato delle lampade (temperatura di funzionamento, consumi, eventuali difetti meccanici che potrebbero provocare danni ecc.) ed implementando sensori di movimento, creare heat map finalizzate alla definizione delle maggiori aree di concentrazione delle persone.

La programmazione dinamica della luce permette la gestione automatica del flusso luminoso della lampada in specifici intervalli di tempo. La funzione CLO consente di mantenere costante il flusso luminoso per tutta la durata di vita del prodotto, bilanciando elettronicamente la riduzione dell'efficienza tipica dei LED. Tutte le informazioni raccolte possono essere archiviate a gestire in loco o da remoto via Cloud.

**Messa in opera e installazione del sistema non incluse nel prezzo.**

## Wireless communication system

**Possibility of implementing several brand technologies**  
**Remote programming and control via on-site gateways**  
**Real-time monitoring of the system status and data collection**  
**Suitable for energy saving relamping**  
**Ideal for commercial, industrial and outdoor applications**

*Extremely efficient system, combining state-of the art- technological solution for the tele-control of light and objects. The system can monitor, control and manage the lighting installations ranging from the single lamp to the whole network.*

*The system allows to the cover extended areas makes it extremely versatile in terms of compatibility with a plurality of devices. This systems is thought to fulfil the need of providing and hoc solutions on the basis of the Customer requests. The system covers a very wide range of applications, ranging from commercial spaces to buildings, industrial plants, public gardens, cities, street and tunnels.*

*By implementing different components it is possible to manage the light at 360°; to make measurements of specific ambient parameters like air pollution and light intensity; to check the luminaire status (temperature, consumptions, any potentially dangerous mechanical faults etc..) and, by implementing movement sensors, to create heat maps aiming at defining the mains areas of people concentration.*

*All the collected information can be stored and managed on site or remotely via Cloud Service. The dynamic programming of the light enables to define an automatic management of the luminous flux emitted by the luminaire on the basis of time slots. The CLO function allows to keep the luminous flux constant along the life cycle of the luminaire, by electronically balancing the efficiency decrease, which is typical of the LEDs.*

**Installation and start-up of the system not included in the price**





# Smart City



Street furniture

# LED Mini Gran Sasso - LED Gran Sasso - LED Maxi Gran Sasso



La certificazione fotometrica dei nostri apparecchi viene sempre effettuata da un istituto esterno. Efficienza luminosa e "lm Output" sono quindi il risultato di tale istituto.

*The photometric certification of our appliances is always carried out by an external institute. Luminous efficiency and "lm Output" are therefore the result of this institute.*

**A richiesta - On demand**

1-10Vdc      DALI 2

DYNA      Wireless

Vedi Pag. VI - See page VI

Gamma di apparecchi a LED per illuminazione di aree urbane. Ideale per l'illuminazione di strade, parcheggi, aree residenziali.

**Installazione:** attacco palo in alluminio pressofuso idoneo per pali di diametro min. 55mm - max. 65mm, orientabile da  $\pm 0$  a  $\pm 90^\circ$ .

**Corpo e telaio:** in alluminio pressofuso UNI EN 1706 verniciato con polvere termoisolante poliesteri.

**Imbocco a palo:** in alluminio pressofuso UNI EN 1706, verniciato con polvere termoisolante poliesteri, con goniometro graduato per un corretto puntamento del fascio luminoso.

**Verniciatura:** di tipo poliesteri eseguita a polvere, resistente agli agenti atmosferici e alla corrosione e garantita per 1.200 ore in nebbia salina (ISO 9227). Colore Nero RAL9005.

**Schermo:** vetro temperato di spessore 4mm resistente agli shock termici e agli urti.

**Ottica:** In PMMA con resistenza alle alte temperature, agli shock termici e agli urti.

**Sorgente:** LED **SAMSUNG LUMILEDS**  
 Mantenimento del flusso luminoso minimo al 90% - (L90B10) >100.000h per il 90% dei LED.

**Temperatura di colore:** 4000K; altre temperature di colore a richiesta (2200K - 2700K - 3000K - 5000K - Consegna 60 giorni).

**Protezione alle sovratensioni inclusa:**  
 Modo differenziale 6kV (L-N)  
 Modo comune 8kV (L-GND, N-GND, L&N-GND)

**A richiesta:** versione con protezione maggiorata (10kV) contro gli impulsi aggiungendo il cod. RO0640/N.

**Driver:** incorporato   
 Fattore di potenza  $\geq 0,98$ .

**Norme di riferimento:** IEC 61000-4-5; EN60598-1; EN60598-2-1; EN62471; EN62031; EN60598-2-3; EN61547

*Range of LED luminaires to light up urban areas. Suitable for roads, car parks and residential areas lighting.*

*Installation: pole attachment in die cast aluminium suitable for poles with a diameter of min. 55mm - max. 65mm, that can be pivoted  $\pm 0$  to  $\pm 90^\circ$ .*

*Housing and frame: made by UNI EN 1706 die-cast aluminium, coated with polyester thermoset powder.*

*Pole entrance: made by UNI EN 1706 die-cast aluminium, coated with polyester thermoset powder, with graduated goniometer to allow the correct orientation of light beam.*

*Coating: coated with powdered polyester, resistant to atmospheric agents, corrosion and guaranteed for 1.200 hours in saline mist (ISO 9227).*

*Black RAL 9005 color.*

*Shield: tempered glass with 4mm thickness resistant to thermal shocks and collisions.*

*Optic: PMMA optic with high temperature resistance, thermal shock and impact resistance*

*Light source: LED **SAMSUNG LUMILEDS**  
 Maintenance of minimum luminous flux to 90% - (L90B10) >100.000h for 90% of LED.*

*Color temperature: 4000K; other color temperatures available on demand (2200K - 2700K - 3000K - 5000K. Delivery time: 60 days)*

*Protection against overvoltages included:  
 Differential mode 6kV (L-N)  
 Standard mode 8kV (L - GND, N-GND, L&N-GND).*

*On demand: this version with greater protection (10kV) with code RO0640/N.*

*Driver: included *

*Power factor  $\geq 0,98$*

*Standard reference: IEC 61000-4-5; EN60598-1; EN60598-2-1; EN62471; EN62031; EN60598-2-3; EN61547*



# LED Mini Gran Sasso - LED Gran Sasso - LED Maxi Gran Sasso



LED Maxi Gran Sasso

LED Gran Sasso

LED Mini Gran Sasso

Apparecchio predisposto  
all'installazione  
su palo (Vedi Pag. 102)  
Device designed  
for pole installation  
(See page 102)

Street furniture



220-240 Vac	110 Vac On demand	50/60 Hz	IP66	IK09	CRI > 70	+45°C -30°C	CE			850°	
	TECEE	LOW FLICKER	RG0	DRIVER INCLUDED MULTIPOWER RIPPLE FREE	RoHS compliance	17 pending					

## LED Mini Gran Sasso

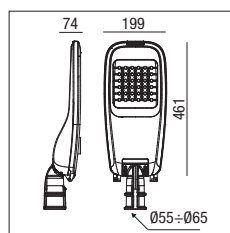

colour	W	Optic	K	nominal lm tc = 25°C	lm output	lm/W	pcs	Kg	CELL
N	20	ST	4000	3.250	2.900	145	1	2,20	346-20-4K
N	20	ST	3000	3.250	2.900	145	1	2,20	346-20-3K
N	30	ST	4000	4.900	4.350	145	1	2,20	346-30-4K
N	30	ST	3000	4.900	4.350	145	1	2,20	346-30-3K
N	40	ST	4000	6.600	5.800	145	1	2,20	346-40-4K
N	40	ST	3000	6.600	5.800	145	1	2,20	346-40-3K
N	50	ST	4000	8.200	7.250	145	1	2,20	346-50-4K
N	50	ST	3000	8.200	7.250	145	1	2,20	346-50-3K
DYNA	N	20	ST	4000	3.250	2.900	1	2,20	346-20-4K-DY
DYNA	N	20	ST	3000	3.250	2.900	1	2,20	346-20-3K-DY
DYNA	N	30	ST	4000	4.900	4.350	1	2,20	346-30-4K-DY
DYNA	N	30	ST	3000	4.900	4.350	1	2,20	346-30-3K-DY
DYNA	N	40	ST	4000	6.600	5.800	1	2,20	346-40-4K-DY
DYNA	N	40	ST	3000	6.600	5.800	1	2,20	346-40-3K-DY
DYNA	N	50	ST	4000	8.200	7.250	1	2,20	346-50-4K-DY
DYNA	N	50	ST	3000	8.200	7.250	1	2,20	346-50-3K-DY

## LED Gran Sasso

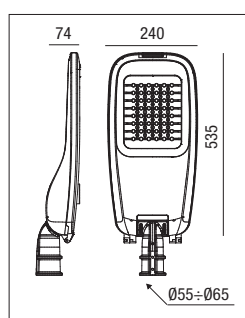

colour	W	Optic	K	nominal lm tc = 25°C	lm output	lm/W	pcs	Kg	CELL
N	60	ST	4000	9.800	8.700	145	1	3,60	346-60-4K
N	60	ST	3000	9.800	8.700	145	1	3,60	346-60-3K
N	75	ST	4000	12.300	10.900	145	1	3,60	346-75-4K
N	75	ST	3000	12.300	10.900	145	1	3,60	346-75-3K
N	90	ST	4000	14.750	13.050	145	1	3,60	346-90-4K
N	90	ST	3000	14.750	13.050	145	1	3,60	346-90-3K
DYNA	N	60	ST	4000	9.800	8.700	1	3,60	346-60-4K-DY
DYNA	N	60	ST	3000	9.800	8.700	1	3,60	346-60-3K-DY
DYNA	N	75	ST	4000	12.300	10.900	1	3,60	346-75-4K-DY
DYNA	N	75	ST	3000	12.300	10.900	1	3,60	346-75-3K-DY
DYNA	N	90	ST	4000	14.750	13.050	1	3,60	346-90-4K-DY
DYNA	N	90	ST	3000	14.750	13.050	1	3,60	346-90-3K-DY

A richiesta versione Zhaga Socket  
On demand Zhaga Socket version

# LED Maxi Gran Sasso

> 100.000 h  
145 Lm/W



	colour	W	Optic	K	nominal lm tc = 25°C	lm output	lm/W	pcs	Kg	CELL
	N	120	ST	4000	19.700	17.400	145	1	4,50	346-120-4K
	N	120	ST	3000	19.700	17.400	145	1	4,50	346-120-3K
	N	140	ST	4000	23.000	20.300	145	1	5,00	346-140-4K
	N	140	ST	3000	23.000	20.300	145	1	5,00	346-140-3K
<b>DYNA</b>	N	120	ST	4000	19.700	17.400	145	1	4,50	346-120-4K-DY
<b>DYNA</b>	N	120	ST	3000	19.700	17.400	145	1	4,50	346-120-3K-DY
<b>DYNA</b>	N	140	ST	4000	23.000	20.300	145	1	5,00	346-140-4K-DY
<b>DYNA</b>	N	140	ST	3000	23.000	20.300	145	1	5,00	346-140-3K-DY

A richiesta versione Zhaga Socket - On demand Zhaga Socket version

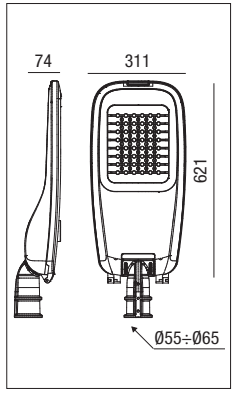

## Ottica di serie Standard optic

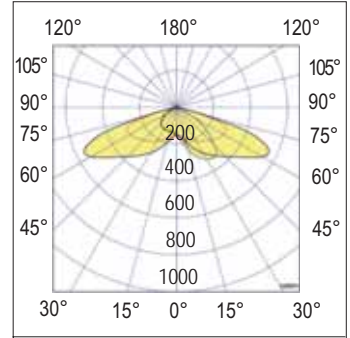

**ST/CDL**  
Stradale - Street optic

## Ottiche a richiesta Optics on demand

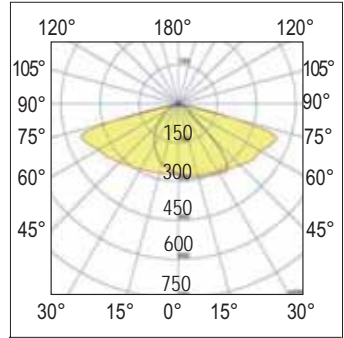

**ST/CDL3**  
Ottica stradale consigliata per piste ciclabili  
Street optic recommended for cycle paths

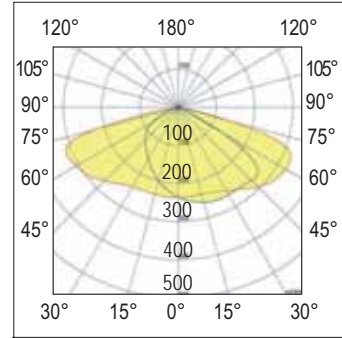

**ST/CDL4**  
Ottica consigliata per illuminazione stradale  
Optic recommended for street lighting

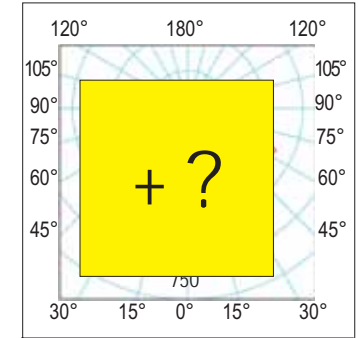

A richiesta è possibile fornire l'apparecchio con ottiche diverse da quelle già proposte  
On request, it is possible to supply the device with optics other than those already proposed

## Gestione del punto luce per un ulteriore risparmio di energia (richiedere preventivo) - Management of the lighting point for further energy savings (Request a quotation)

Regolazione 1÷10V 1-10V control	Mezzanotte virtuale Virtual midnight	Zhaga Socket	Telegestione sistema Wi-Fi (da concordare) - Wi-Fi system remote management (to be agreed)
Possibilità di regolazione 10% - 100% con sistema 1÷10V Possibility of adjustment 10% - 100% with 1-10V system	Sistema con riduzione automatica del flusso System with automatic flux reduction	Predisposizione sul corpo dell'apparecchio. Ideale per la gestione dell'illuminazione autonoma locale tramite sensori o da remoto. For installation on the body of the appliance. Ideal for autonomous management of the lighting, either locally with sensors or remotely	Sistema di controllo, gestione consumi e diagnosi dell'impianto con tecnologia Wi-Fi Control system, consumption management and diagnosis of the system with Wi-Fi technology

# LED Mini Gran Sasso - LED Gran Sasso - LED Maxi Gran Sasso

Gestione del punto luce per un ulteriore risparmio di energia (richiedere preventivo) - *Management of the lighting point for further energy savings (Request a quotation)*

Mezzanotte virtuale - *Virtual midnight*

Sistema con riduzione automatica del flusso - *System with automatic flux reduction*

## DYNA control - Mezzanotte virtuale - Virtual midnight

**DYNA**

Il settaggio del FLUSSO LUMINOSO avviene con programmazione della corrente di pilotaggio. Tale programmazione va richiesta in sede, durante la fase d'ordine / progetto.

*The LUMINOUS FLUX setting is done by programming the driving current. This programming must be requested on site, during the order / project phase*

DYNA CONTROL è un sistema automatico di controllo del flusso luminoso delle lampade. Il sistema entra in funzione alla prima accensione calcolando per 3 giorni i tempi di accensione, il quarto giorno il sistema in modo autonomo calcola la mezzanotte virtuale eseguendo una regolazione del flusso regolando la lampada come indicato sullo schema di Fig. 1; per i primi tre giorni quindi il sistema manterrà le lampade accese al 100%, nel tempo di accensione dell'impianto, il quarto giorno entrerà in funzione il sistema DYNA CONTROL gestendo in modo autonomo il flusso luminoso garantendo così un notevole risparmio energetico. Accensioni inferiori ad 1 ora (es. manutenzione) verranno ignorate ed il sistema non entra in funzione, per accensioni da 1 a 4 ore (es. anomalia impianto) o superiori alle 23 ore (es. impianto sempre acceso), il sistema resetta il timer quindi ricomincerà a contare per i primi 3 giorni e successivamente riprenderà il funzionamento automatico.

*DYNA CONTROL is an automatic system to control lamp brightness. The system starts working when first switched-on calculating switch-on times for 3 days, on the fourth day the system autonomously calculates the virtual midnight, adjusting the brightness of the lamp as indicated in fig.1. Therefore, for the first three days the system will keep the lamps on at 100%, during system switch-on, on the fourth day, the DYNA CONTROL system will start operating autonomously, controlling the lamp's brightness, thus ensuring significant energy savings.*

*Switch-on of less than 1 hour (ex. for maintenance) will be ignored and the system will not operate. For switch-on times from 1 to 4 hours (ex. system anomaly) or over 23 hours (ex. system always on), the system resets the timer and will restart counting for the first 3 days and then resume to automatic operation.*

Fig. 1 - Esempio applicativo 5 steps - *Application example 5 steps*

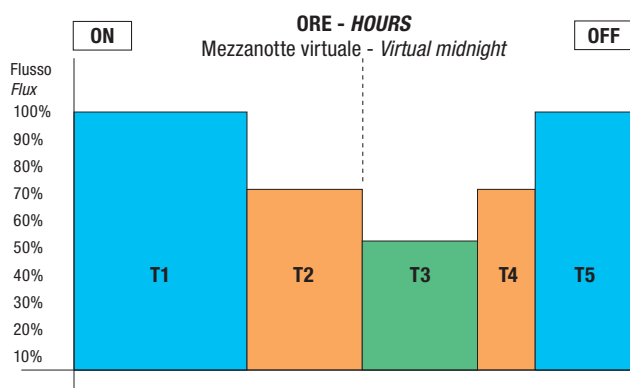

T1 = 30% "T" - 100% Flusso luminoso - <i>Luminous flux</i>
T2 = 20% "T" - 70% Flusso luminoso - <i>Luminous flux</i>
T3 = 20% "T" - 50% Flusso luminoso - <i>Luminous flux</i>
T4 = 10% "T" - 70% Flusso luminoso - <i>Luminous flux</i>
T5 = 20% "T" - 100% Flusso luminoso - <i>Luminous flux</i>

Minimo tempo di accensione per funzionamento automatico 4 ore (3 giorni).  
Accensioni di 1 ora ignorate.

Accensioni da 1 a 4 ore oppure superiori alle 23 ore resettano il sistema.

*The minimum ignition time for automatic operation is 4 hours (three days).  
Ignitions 1 hour ignored.*

*Switching from 1 to 4 hours or higher with 23 hours reset the system.*

## Accessori non inclusi - *Not included accessories*



Code: RO0640/N

### PROTEZIONE ALLE SOVRATENSIONI

In un impianto elettrico standard un apparecchio a LED può essere sottoposto a sbalzi di tensione e disturbi esterni dovuti a fattori quali carichi discontinui sulla linea, guasti sulle linee a monte o a valle e, soprattutto, scariche atmosferiche (negli impianti esterni).

Nei nostri proiettori, dove l'elettronica è fondamentale, la resistenza alle sovratensioni è sinonimo di affidabilità e corretta funzionalità.

### SURGE PROTECTOR

*In a standard electrical system an LED luminaire can be subjected to voltage fluctuations and external disturbances due to factors such as discontinuous loads on the line, faults on the lines upstream or downstream and, especially, atmospheric discharges (in External Plants).*

*In our projectors, where electronics is very important, the surge resistance is synonymous with reliability and proper functionality.*



Code: 220001236

Braccio a parete  
*Wall bracket*

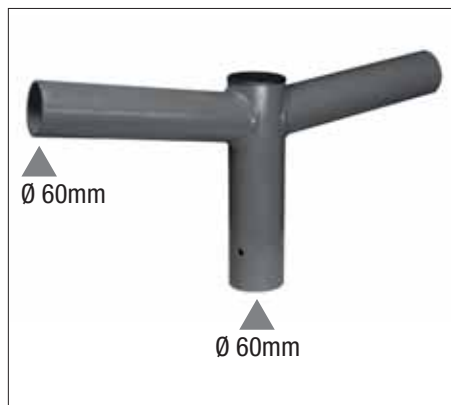

Cod. 802020.0101

Braccio 2X - *2X bracket*



### ZHAGA SOCKET

- Connettore max 30Vdc - max 1,5A  
Connector max 30Vdc - max 1,5A  
Code: 488787561

- Tappo IP66 - Cap connector IP66  
Code: 488787581



## LED Monza round



Sistema LED lineare per applicazioni professionali nell'illuminazione di facciate, portici, sottopassaggi e in generale per l'illuminazione di particolari elementi architettonici. A richiesta è possibile collegare gli apparecchi in serie per ottenere delle linee di luce continua.

**Installazione:** su superfici verticali e orizzontali (completo di staffa di fissaggio).

**Corpo:** in policarbonato trasparente, resistente agli urti.

**Testate di chiusura:** in PVC, colore nero

**Staffa di fissaggio:** in alluminio, verniciata con polvere termoindurente poliesteri

**Guarnizione:** in gomma ai siliconi dalle rilevanti prestazioni meccaniche ed elastiche

**Dispositivo anticondensa:** valvola di compensazione e riciclo dell'aria

Norme di riferimento

EN60598-1; EN60598-2-1; EN62471; EN62031; EN61547

**Sorgente:** LUMILEDS 3528

Mantenimento del flusso luminoso minimo al 80% - 50.000h (L80B10) per il 90% dei LED.

**Temperatura di colore:** 2200K, 3000K e 4000K

**Cablaggio:** 1,5m di cavo tipo H07RN-F 2x1mm<sup>2</sup>

**Driver:** incorporato  Fattore di potenza ≥0,95

*LED linear system for professional lighting applications on facades, arcades, tunnels and generally to light up particular architectural elements. On demand it is possible to make a serial connection of the luminaires to have continuous light lines. The very low energy consumption and a lifespan exceeding 30.000 hours make the profiles ideal both for installations in new electrical systems and replacement of luminaires with traditional light sources.*

**Installation:** on vertical and horizontal surfaces (complete with fixing bracket)

**Housing:** made by transparent polycarbonate, resistant to collisions

**End caps:** made by PVC, black color

**Fixing bracket:** made by aluminum, coated with polyester thermoset powder

**Gasket:** made by silicone rubber with high mechanical and elastic performance

**Anti-condensate device:** valve for compensation and circulation of air

Standard reference

EN60598-1; EN60598-2-1; EN62471; EN62031; EN61547

**Light source:** LUMILEDS 3528

Maintenance of 80% minimum luminous flux: 50,000h (L80B10) for 90% of the LEDs.

**Color temperature:** 2200K, 3000K and 4000K

**Wiring:** 1,5m cable type H07RN-F 2x1mm<sup>2</sup>

**Driver:** included  Power factor ≥0,95

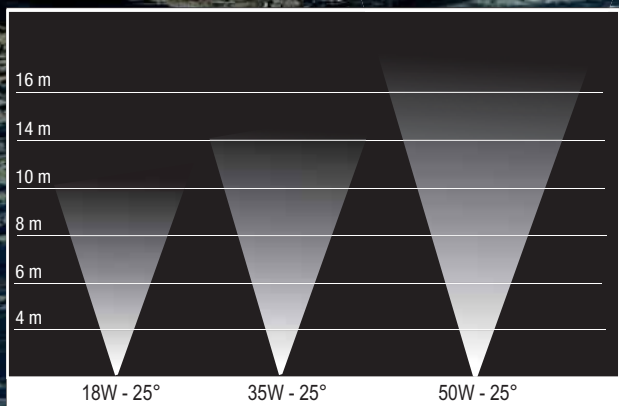

A richiesta  
On demand

1-10Vdc

Pag. VI

**DALI** 2

Pag. VI

220-240 Vac	110 Vac On demand	50/60 Hz	IP67	IK09	CRI 90	+40 C° -20	850°	CE		
<b>Driver included</b> 		 DIM a richiesta on demand								

## LED Monza round

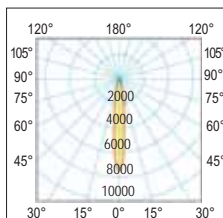

**10°**  
Concentrante  
*Narrow*  
Schermo trasparente standard  
Standard transparent shield

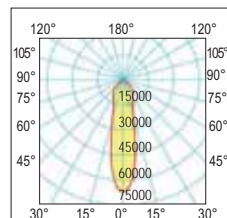

**25°**  
Semi-concentrante  
*Spot*  
Schermo trasparente standard  
Standard transparent shield



### LED Monza round 70 Wall Washer

colour	W	angle	K	nominal lm tc = 25°C	lm output	lm/W	pcs	Kg	CELL
	18	10°	3000	2600	2160	120	1	0,92	27334/R/10/3K
	18	10°	4000	2600	2160	120	1	0,92	27334/R/10
	18	25°	3000	2600	2160	120	1	0,92	27334/R/3K
	18	25°	4000	2600	2160	120	1	0,92	27334/R

**A richiesta:** per quantità minima 100 pezzi disponibili a 2200K - *On demand:* for quantity min 100 pcs available 2200K



### LED Monza round 100

colour	W	angle	K	nominal lm tc = 25°C	lm output	lm/W	pcs	Kg	CELL
	35	10°	3000	5040	4200	120	1	1,20	27339/R/10/3K
	35	10°	4000	5040	4200	120	1	1,20	27339/R/10
	35	10°	4000	5040	4200	120	1	1,20	27339/R/10/DA
	35	25°	3000	5040	4200	120	1	1,20	27333/R/3K
	35	25°	4000	5040	4200	120	1	1,20	27333/R
	50	10°	4000	6300	5500	110	1	1,20	27339/R/10/50
	50	25°	4000	6300	5500	110	1	1,20	27339/R/25/50

**A richiesta:** per quantità minima 100 pezzi disponibili a 2200K - *On demand:* for quantity min 100 pcs available 2200K



**Dispositivo anticondensa**  
Valvola di compensazione e riciclo dell'aria.  
*Anti-condensate device*  
Valve for compensation and circulation of air.

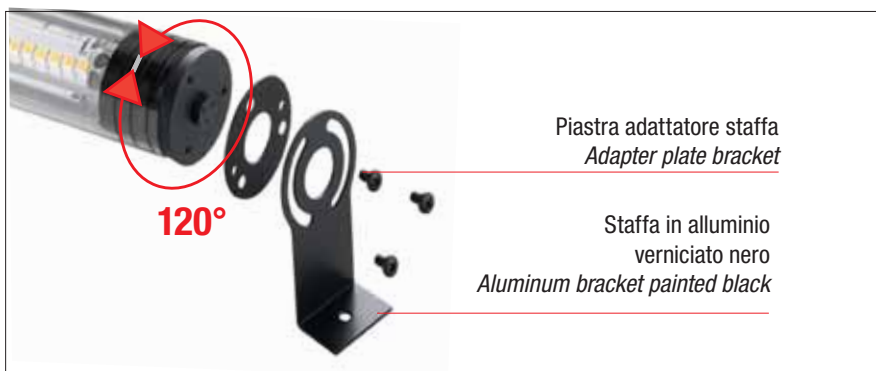



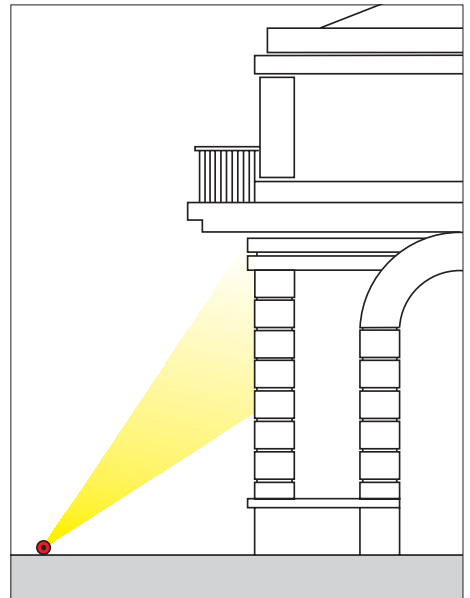
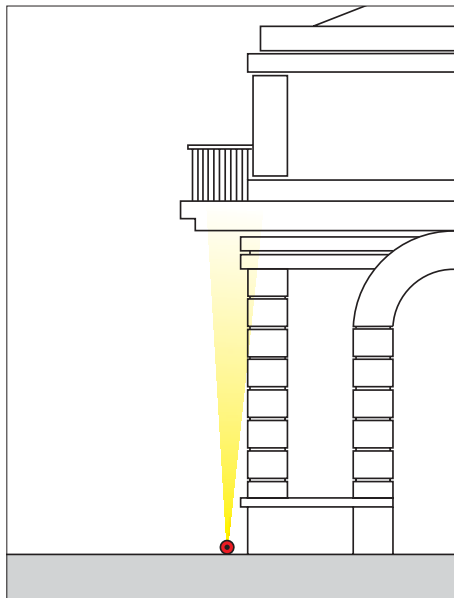
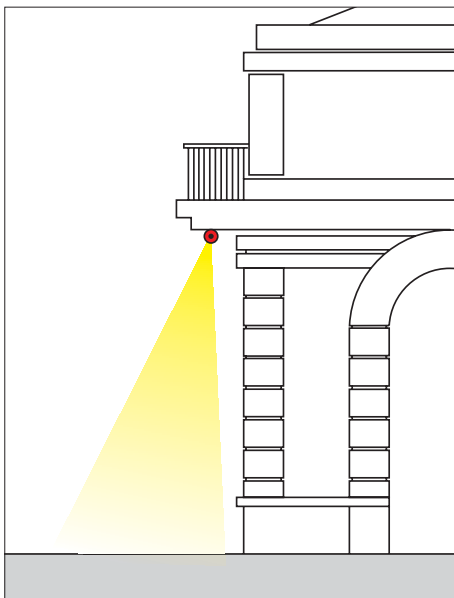

**Accessori non inclusi - Not included accessories**



IP67



IP67

Cod. XPG9-P104  
 Accessorio IP67 per linee di luce continua  
 IP67 accessory for continuous light lines.

Cod. XYPG9-IKP67  
 Accessorio IP68 per linee di luce continua  
 IP68 accessory for continuous light lines.



# LED Tuba Lux

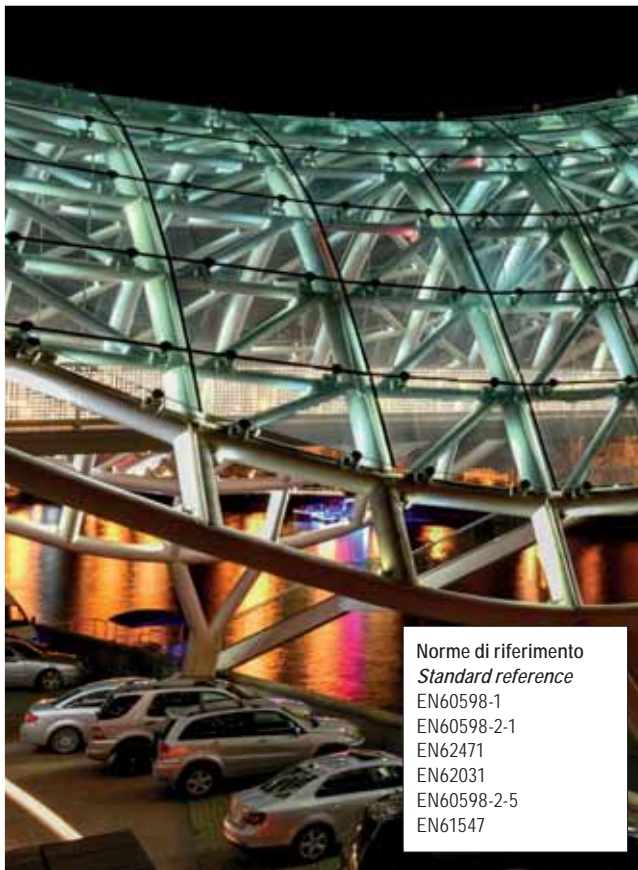

Norme di riferimento  
Standard reference  
EN60598-1  
EN60598-2-1  
EN62471  
EN62031  
EN60598-2-5  
EN61547

Sistema LED lineare per applicazioni professionali nell'illuminazione di facciate, portici, sottopassaggi e in generale per l'illuminazione di particolari elementi architettonici. A richiesta è possibile collegare gli apparecchi in serie per ottenere delle linee di luce.

**Installazione:** su superfici verticali e orizzontali (completo di staffa di fissaggio).

**Corpo:** in policarbonato opale, resistente agli urti.

**Testate di chiusura:** in acciaio Inox

**Staffa di fissaggio:** in acciaio Inox

**Guarnizione:** in gomma ai siliconi dalle rilevanti prestazioni meccaniche ed elastiche

**Dispositivo anticondensa:** valvola di compensazione e riciclo dell'aria

Sorgente: **SAMSUNG - CREE**

Mantenimento del flusso luminoso minimo al 80% - 50.000h (L80B10) per il 90% dei LED.

**Temperatura di colore:** 3000K o 4000K;

**Cablaggio:** 1.250cm di cavo tipo H07RN-F 2x1mm<sup>2</sup>

**Driver:** incorporato . Fattore di potenza ≥0,95

*LED linear system for professional lighting applications on facades, arcades, tunnels and generally to light up particular architectural elements. On demand it is possible to make a serial connection of the luminaires to have light lines. The very low energy consumption and a life-span exceeding 30.000 hours make the profiles ideal both for installations in new electrical systems and replacement of luminaires with traditional light sources.*

**Installation:** on vertical and horizontal surfaces (complete with fixing bracket)

**Housing:** made by opal polycarbonate, resistant to collisions

**End caps:** made in Inox steel

**Fixing bracket:** made Inox steel

**Gasket:** made by silicone rubber with high mechanical and elastic performance

**Anti-condensate device:** valve for compensation and circulation of air

Light source: **SAMSUNG - CREE**

Maintenance of 80% minimum luminous flux: 50,000h (L80B10) for 90% of the LEDs.

**Color temperature:** 3000K or 4000K;

**Wiring:** 1.250cm cable type H07RN-F 2x1mm<sup>2</sup>

**Driver:** included . Power factor ≥0,95

Outdoor

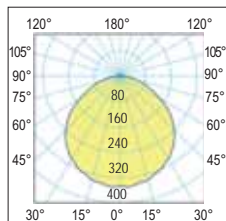

180°  
Diffondente - Wide

A richiesta - On demand: Emergency version



220-240  
Vac

110 a richiesta  
Vac on demand

50/60  
Hz

IP67

IK09

CRI  
90



+40  
C°  
-20

+50  
C°  
-20 a richiesta  
on demand



850°

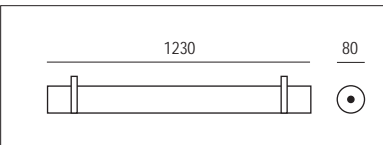

**DALI 2**

**DALI 2**

colour	W	angle	K	nominal lm tc = 25°C	lm output	lm/W	pcs	Kg	CELL
OP	50	180°	3000	5.000	4.000	80	1	2,00	27339/TU/OP3K
OP	50	180°	3000	5.000	4.000	80	1	2,00	27339/TU/3KDA
OP	50	180°	4000	5.000	4.000	80	1	2,00	27339/TUBA/OP
OP	50	180°	4000	5.000	4.000	80	1	2,00	27339/TU/4KDA



1.250 cm di cavo tipo H07RN-F 2x1mm<sup>2</sup>  
1.250 cm cable type H07RN-F 2x1mm<sup>2</sup>



Connettore IP68 per una rapida installazione  
IP68 connector for quick installation



Dispositivo anticondensa  
Anti-condensate device

# LED Tuba Lux

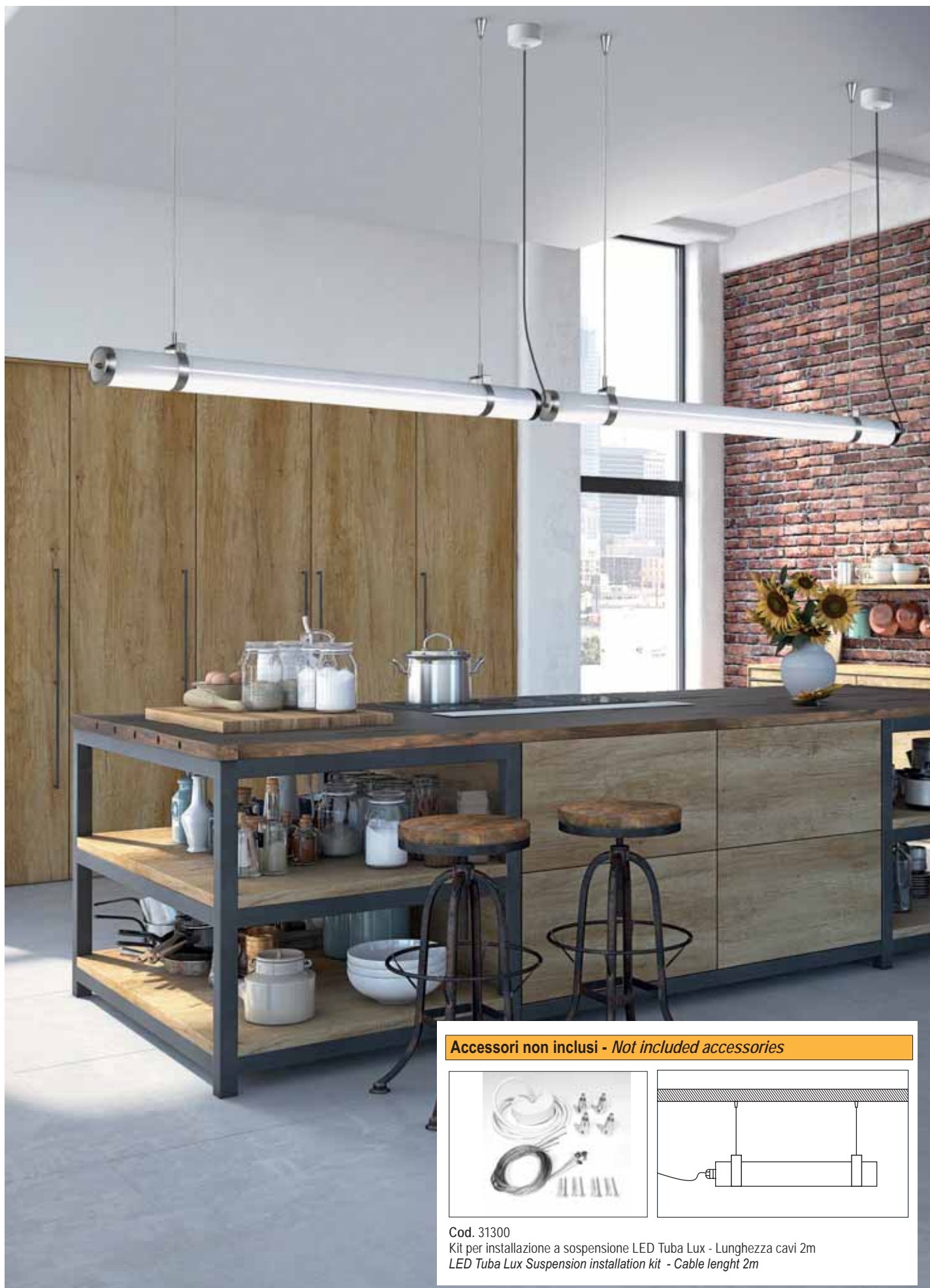

Outdoor

## Accessori non inclusi - Not included accessories

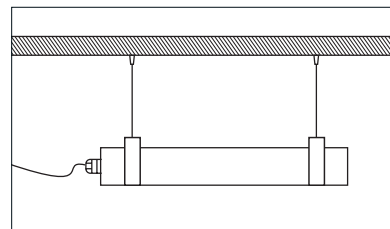

Cod. 31300  
Kit per installazione a sospensione LED Tuba Lux - Lunghezza cavi 2m  
LED Tuba Lux Suspension installation kit - Cable length 2m



## LED Positano - LED Gargano

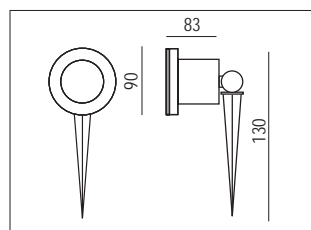

**Norme di riferimento**  
**Standard reference**  
 EN60598-1  
 EN60598-2-1  
 EN62471  
 EN62031  
 EN60598-2-5  
 EN61547

Faretto ad illuminazione d'accento concepito per l'illuminazione di aree esterne. Costituisce uno strumento efficace per l'illuminazione di arredi, percorsi, porticati ed altri elementi architettonici, ma anche gruppi di vegetazione come alberi e cespugli.

**Corpo:** materiale termoplastico (Positano), alluminio pressofuso (Gargano)

**Schermo:** vetro temprato resistente agli shock termici e agli urti

**Cablaggio:** completo di cavo 3m (VDE H05RR-F - 2x1mm<sup>2</sup>) e spina Schuko

**Sorgente:** lampadina LED GU10 (Positano), LED SMD (Gargano)

**Accessori inclusi:** picchetto, staffa di fissaggio a parete e lampadina (solo per Positano)

**Ghiera Gargano:** alluminio. Verniciatura di tipo poliestere eseguita a polvere resistente agli agenti atmosferici e alla nebbia salina.

*Spot-light with accentuated lighting for use in indoor or outdoor where a high degree IP protection is required.*

*It is an efficient means of lighting objects, parths, porches and other architectural features, as well as vegetation such a trees and shrubs.*

*Housing: thermoplastic material*

*Shield: tempered glass resistant against thermal shocks and collision*

*Wiring: complete with 3m wire (VDE H05RR-F - 2x1mm<sup>2</sup>) and schuko plug*

*Source: GU10 LED lamp*

*Included accessories: spike, wall fitting bracket and lamp*

220-240 Vac	50/60 Hz	IP66	IK08	CRI >80	+40 C -20			
colour	W	LED	K	lm	pcs	Kg	S + L	
<b>N</b>	6	Led GU10 lamp	4000	450	1	0,80	02012/LEDGU10	
<b>N</b>	6	Led GU10 lamp	3000	450	1	0,80	02013/LEDGU10	





# LED Gargano Design by Ezio Didone

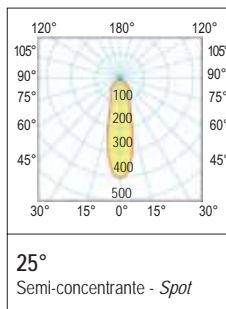

220-240 Vac    50/60 Hz    IP67    IK10    CRI >80    +40°C / -20°C    850°   

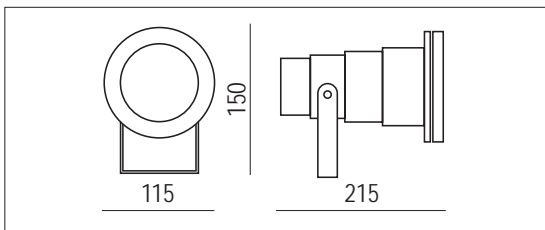

colour	W	angle	K	lm Output	pcs	Kg	CELL
<b>N</b>	10	25°	4000	914	1	0,80	24285/LED
<b>N</b>	10	25°	3000	914	1	0,80	24286/LED
<b>G</b>	10	25°	3000	914	1	0,80	24290/LED
<b>G</b>	10	25°	4000	914	1	0,80	24284/LED
<b>N</b>	4	45°	3000	400	1	0,80	24280/LEGU10

**A richiesta:** per quantità disponibile versione 2700K e 5000K - **On demand:** for quantity, available 2700K and 5000K version

## Accessori non inclusi - Not included accessories



Cassaforma per installazione a pavimento Framework for floor installation				
colour	H (mm)	pcs	Kg	S
<b>N</b>	240	1	1,00	24134
<b>G</b>	240	1	1,00	24135



Frangiluce - Louver				
colour	Ø (mm)	pcs	Kg	S
<b>N</b>	150	1	1,00	24136
<b>G</b>	150	1	1,00	24137



Frangiluce - Louver				
colour	Ø (mm)	pcs	Kg	S
<b>N</b>	150	1	1,00	24138
<b>G</b>	150	1	1,00	24139



Outdoor



Cod. 24165  
Picchetto in alluminio  
Aluminium spike



Cod. XPG9-P104  
Accessorio IP67 per linee di luce continua  
IP67 accessory for continuous light lines.



Cod. XYPG9-IP67  
Accessorio IP68 per linee di luce continua  
IP68 accessory for continuous light lines.

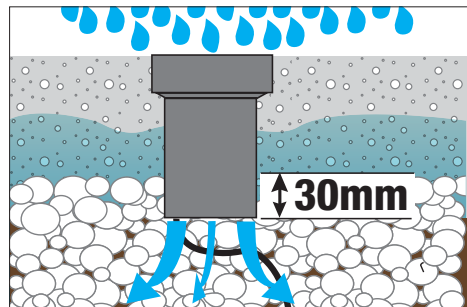

Al fine di permettere un adeguato drenaggio si consiglia di preparare un fondo di ghiaia in fase di installazione. Per il collegamento è necessario utilizzare connettori stagni. We advise you to prepare a gravel drain fund for installing the products, to ensure suitable drainage. For the connection it is necessary to use waterproof connectors.

# LED Capri - LED Capri Mini



Outdoor

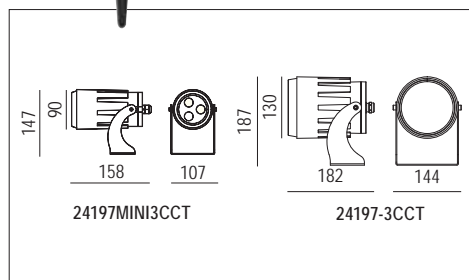

Norme di riferimento  
Standard reference  
EN60598-1  
EN60598-2-1  
EN62471  
EN62031  
EN60598-2-5  
EN61547

LED Capri è un apparecchio da esterno, ad alto grado di protezione, utilizzabile sia tramite staffa di fissaggio da terra o parete (inclusa) che con picchetto (da ordinare separatamente), ideale per illuminare facciate giardini, parchi, aiuole, terrazzi.

**Corpo e telaio:** in alluminio pressofuso UNI EN 1706 verniciato con polvere termoisolante poliester

**Staffa di fissaggio:** in acciaio, verniciata con polvere termoisolante poliester

**Verniciatura:** di tipo poliester eseguita a polvere, resistente agli agenti atmosferici e alla corrosione e garantita per 1.000 ore in nebbia salina. Colore Nero RAL 9005.

**Schermo:** vetro temprato di spessore 4mm resistente agli shock termici e agli urti.

**Driver:** incorporato

**Sorgente:** LED **CREE** Fattore di potenza  $\geq 0,92$ . Mantenimento del flusso luminoso al 80%. 50.000h (L80B20).

*The Capri LED is an outdoor appliance with a high degree of protection, which can also be used with a floor or wall fixing bracket (included) or with a stake (to be ordered separately), ideal for illuminating façades in gardens, parks, flowerbeds, terraces.*

*Housing and frame: made by UNI EN 1706 die-cast aluminum, coated with polyester thermoset powder*

*Fixing bracket: made by stainless steel, coated with polyester thermoset powder*

*Coating: coated with powdered polyester, resistant to atmospheric agents, corrosion and guaranteed for 1.000 hours in saline mist. Black RAL9005 color.*

*Optic: clumping*

*Shield: tempered glass with 4mm thickness resistant to thermal shocks and collisions*

*Driver: included*

*Light source: LED **CREE** Power factor  $\geq 0,92$ . maintenance of 80% minimum luminous flux: 50,000h (L80B20).*

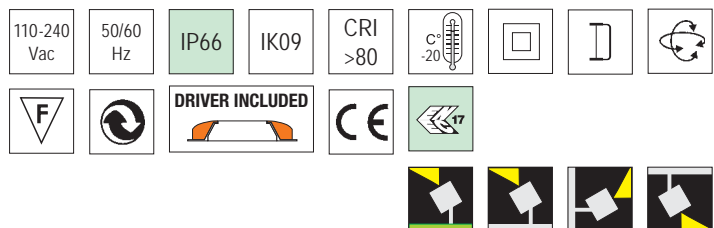

colour	W	Optic	K			lm	pcs	Kg	CELL	
<b>N</b>	9	30°	2700	3000	4000	710	1	1,30	24197MINI3CCT	<b>3CCT SWITCHABLE</b>
<b>N</b>	27	30°	4000			2230	1	1,60	24197	
<b>N</b>	27	30°	2700	3000	4000	2230	1	1,60	24197-3CCT	<b>3CCT SWITCHABLE</b>



Funzione 3 CCT (2700K - 3000K - 4000K) modificabile con interruttore a cursore

Slide switch 3 CCT (2700K - 3000K - 4000K) changeable function

**Accessori non inclusi**  
Not i included accessories



Cod. 24165  
Picchetto in alluminio  
**ACCESSORIO NON INCLUSO**  
**NOT INCLUDED**  
**ACCESSORY**  
aluminium spike

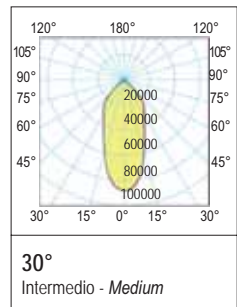



# LED Capri - LED Capri Mini



Outdoor



## LED Ischia



LED Ischia è un apparecchio da esterno, ad alto grado di protezione, utilizzabile sia tramite staffa di fissaggio da terra o parete (inclusa), con picchetto (da ordinare separatamente) o da palo (da ordinare separatamente), ideale per illuminare facciate giardini, parchi, aiuole, terrazzi.

**Corpo e telaio:** in alluminio pressofuso UNI EN 1706 verniciato con polvere termoindurente poliestere

**Verniciatura:** di tipo poliestere eseguita a polvere, resistente agli agenti atmosferici e alla corrosione e garantita per 1.000 ore in nebbia salina. Colore Nero RAL 9005.

**Ottica:** con lenti in PC ad alto confort visivo e buon effetto antiriflesso.

**Schermo:** vetro temprato di spessore 4mm super bianco resistente agli shock termici e agli urti.

**Driver:** incorporato

**Sorgente:** LED Fattore di potenza  $\geq 0,92$ . Mantenimento del flusso luminoso al 80%. 50.000h (L80B20)

**A richiesta:** DALI 2 e DMX.

**Norme di riferimento:** EN60598-1; EN60598-2-1; EN62471; EN62031; EN60598-2-5; EN61547

*The Capri LED is an outdoor appliance with a high degree of protection, which can also be used with a floor or wall fixing bracket (included) or with a stake (to be ordered separately), ideal for illuminating façades in gardens, parks, flowerbeds, terraces.*

*Housing and frame: made by UNI EN 1706 die-cast aluminum, coated with polyester thermoset powder*

*Coating: coated with powdered polyester, resistant to atmospheric agents, corrosion and guaranteed for 1.000 hours in saline mist. Black RAL9005 color.*

*Optic: with PC lenses with high visual comfort and good anti glare effect*

*Shield: tempered glass with 4mm thickness super white resistant to thermal shocks and collisions*

*Driver: included*

*Light source: LED Power factor  $\geq 0,92$ . maintenance of 80% minimum luminous flux: 50,000h (L80B20).*

**On demand:** DALI 2 and DMX.

**Standard reference:** EN60598-1; EN60598-2-1; EN62471; EN62031; EN60598-2-5; EN61547

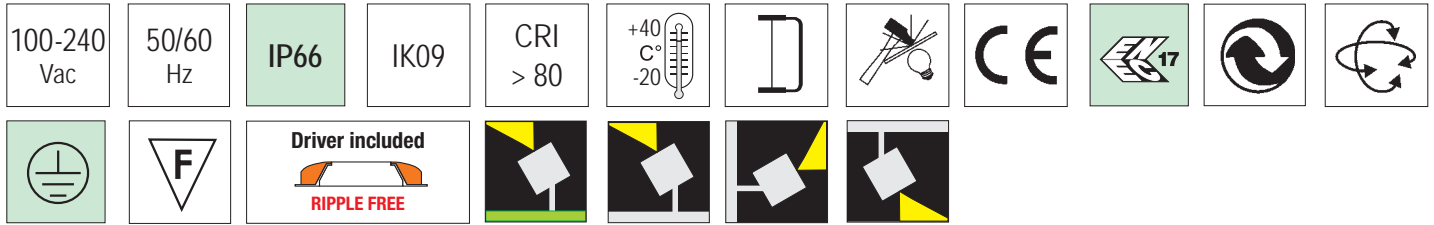

## LED Ischia 1

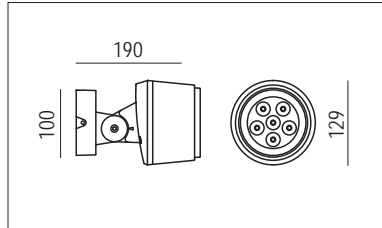

**Orientabilità**  
 inclinazione del corpo  
 lampada  $\pm 90^\circ$   
**Adjustability**  
 inclination of the lamp  
 body  $\pm 90^\circ$

colour	W	Optic	K	Lm/W	lm Output	pcs	Kg	CELL
<b>N</b>	18	40°	3000	144	2.600	1	1,80	215-18-40-3K
<b>N</b>	18	40°	2200	130	2.400	1	1,80	215-18-40-2K
<b>N</b>	18	40°	4000	144	2.600	1	1,80	215-18-40-4K

## LED Ischia 2

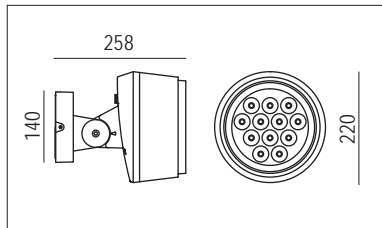

**Orientabilità**  
 inclinazione del corpo  
 lampada  $\pm 90^\circ$   
**Adjustability**  
 inclination of the lamp  
 body  $\pm 90^\circ$

colour	W	Optic	K	Lm/W	lm Output	pcs	Kg	CELL
<b>N</b>	40	40°	3000	130	5200	1	3,80	215-40-40-3K
<b>N</b>	40	40°	2200	130	4800	1	3,80	215-40-40-2K
<b>N</b>	40	40°	4000	130	5200	1	3,80	215-40-40-4K

### Dettaglio ottiche - Optical detail

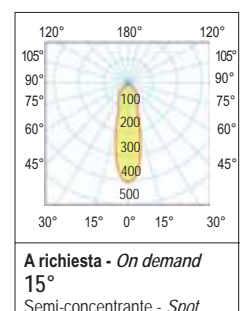
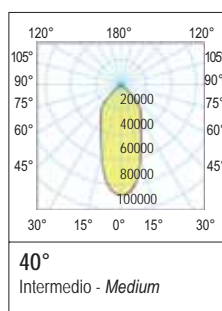
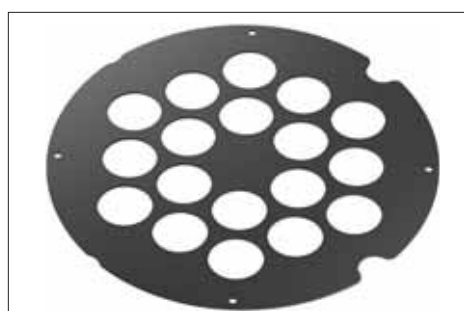









# LED Ischia

Accessori non inclusi LED ISCHIA 40W - *Not included accessories LED ISCHIA 40W*



colour	Descrizione - Description	Code
N	Gancio singolo per applicazione su palo Ø 100 mm per LED Ischia 40W <i>Single Bracket for pole application Ø 100 mm LED Ischia 40W</i>	TG-215-AB
N	Gancio singolo per applicazione su palo Ø 120 mm per LED Ischia 40W <i>Single Bracket for pole application Ø 120 mm LED Ischia 40W</i>	TG-215-A
N	Gancio doppio per applicazione su palo Ø 100 mm per LED Ischia 40W <i>Double Bracket for pole application Ø 100 mm LED Ischia 40W</i>	TG-215-BA
N	Gancio doppio per applicazione su palo Ø 120 mm per LED Ischia 40W <i>Double Bracket for pole application Ø 120 mm LED Ischia 40W</i>	TG-215-B

Outdoor

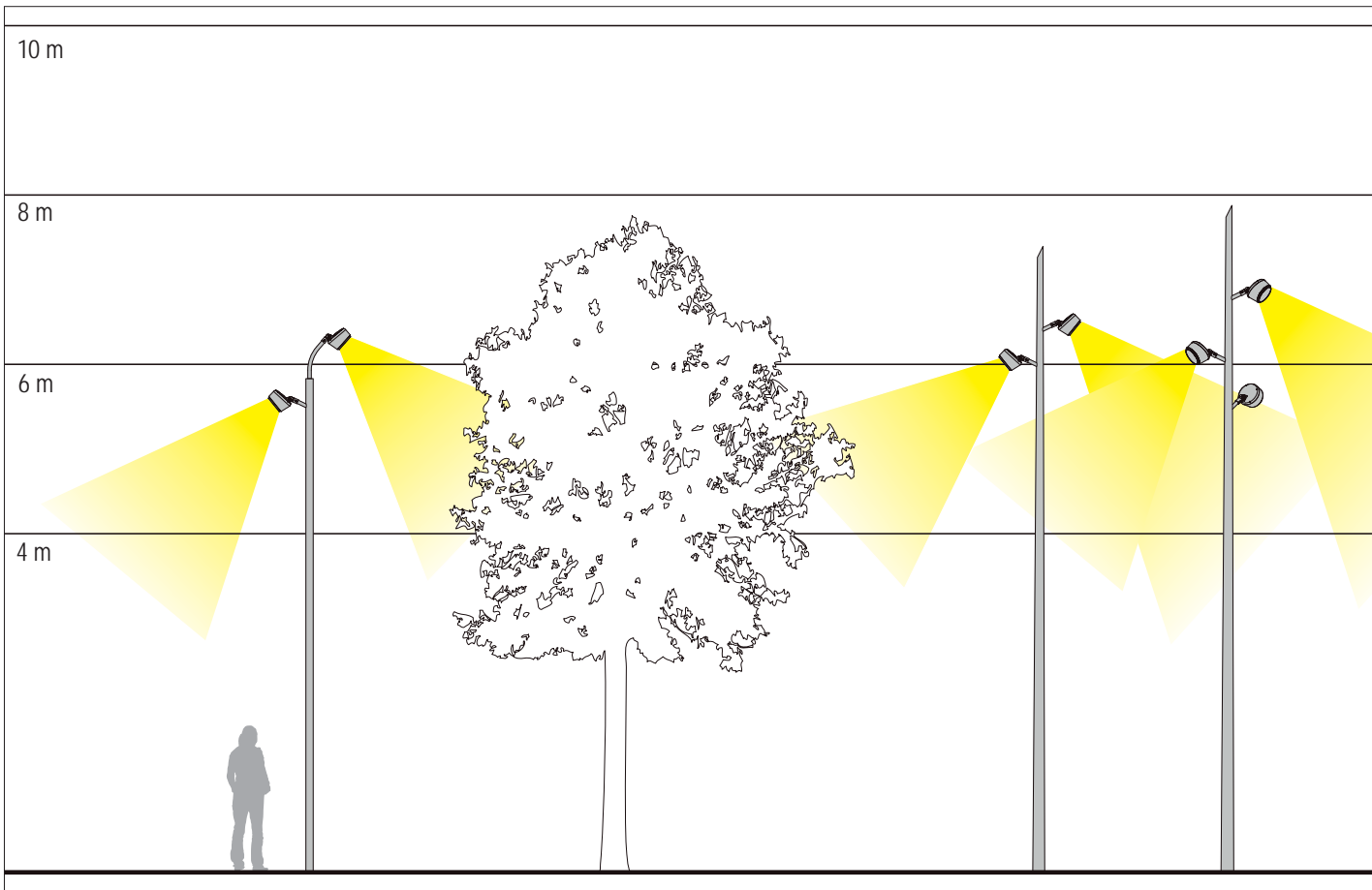



# LED Ischia

Accessori non inclusi - *Not included accessories*

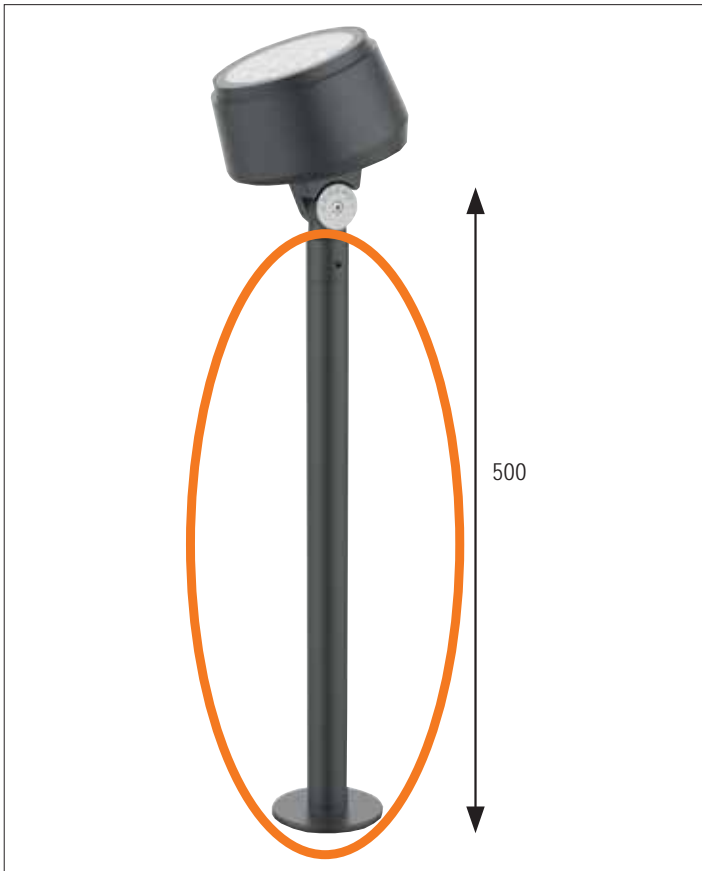

Cod. 215PA  
Palo per LED Ischia - *LED Ischia pole*



Cod. 24165  
Picchetto in alluminio - *Aluminium spike*

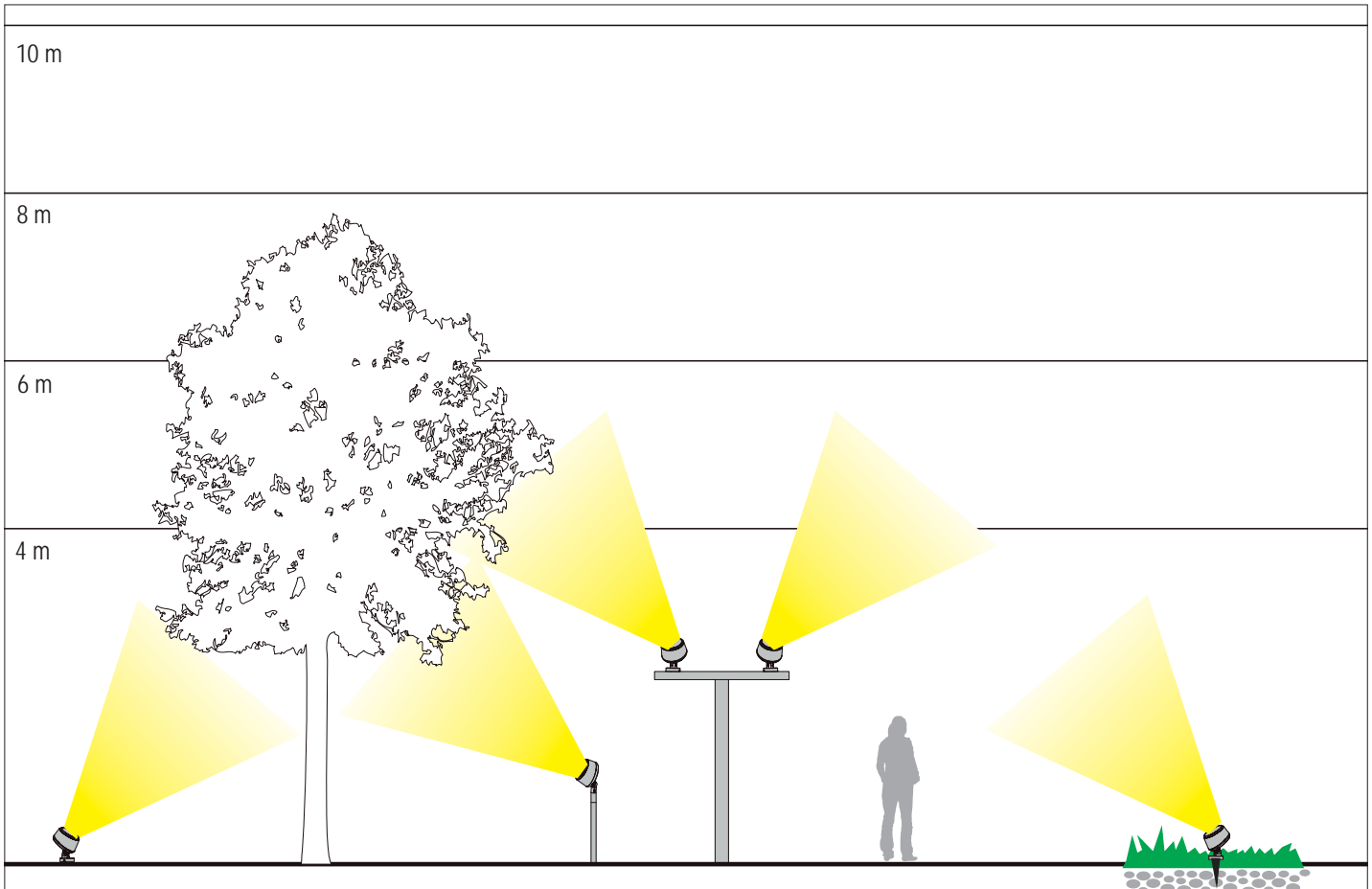



# LED Ovest

**3in1**

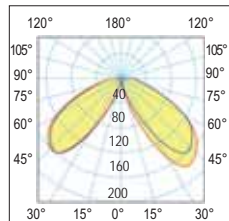

360°  
Diffondente - Wide

**Norme di riferimento**  
*Standard reference*  
EN60598-1  
EN60598-2-1  
EN62471  
EN62031  
EN60598-2-5  
EN61547

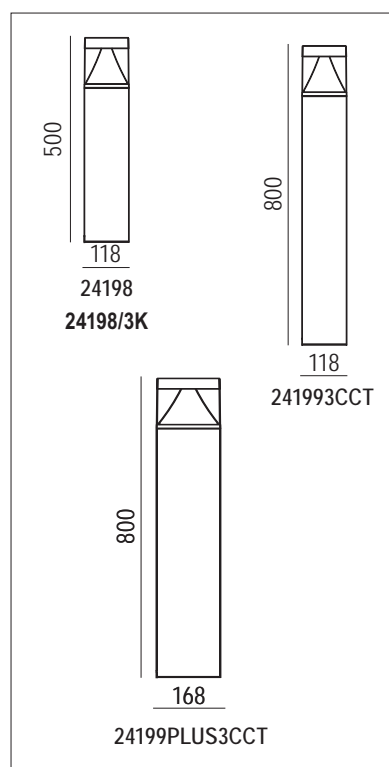

Paletto per l'illuminazione di giardini o parchi, con effetto di luce discreta.

**Installazione:** a terra

**Corpo:** in alluminio pressofuso UNI EN 1706, verniciato con polvere termoisolante poliestere

**Verniciatura:** di tipo poliestere eseguita a polvere, resistente agli agenti atmosferici e alla corrosione e garantita per 1.000 ore in nebbia salina. Colore Nero RAL 9005.

**Diffusore:** in policarbonato trasparente

**Driver:** incorporato

**Sorgente:** LED. Fattore di potenza  $\geq 0,92$ . Mantenimento del flusso luminoso al 80%. 50.000h (L80B20)

*Lighting bollard suitable for installation in gardens or parks, with soft effect.*

*Installation: on ground*

*Housing: made by UNI EN 1706 die-cast aluminum, coated with polyester thermoset powder*

*Coating: coated with powdered polyester, resistant to atmospheric agents, corrosion and guaranteed for 1.000 hours in saline mist. Black RAL9005 color.*

*Diffuser: made by transparent polycarbonate*

*Driver: included*

*Light source: LED. Power factor  $\geq 0,92$ . maintenance of 80% minimum luminous flux: 50,000h (L80B20).*

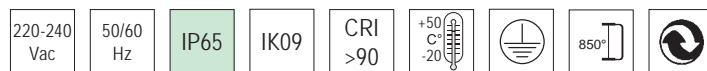

colour	H mm	W	Optic	K			lm	pcs	Kg	CELL
N	500	9,7	130°	4000			600	1	2,50	24198
N	500	9,7	130°	3000			600	1	2,50	24198/3K
N	800	9,7	130°	2700	3000	4000	600	1	5,00	241993CCT
N	800	25	130°	2700	3000	4000	2.250	1	5,00	24199PLUS3CCT

3CCT SWITCHABLE

3CCT SWITCHABLE



Funzione 3 CCT (2700K - 3000K - 4000K) modificabile con interruttore a cursore  
*Slide switch 3 CCT (2700K - 3000K - 4000K) changeable function*

A richiesta  
*On demand*

**1-10Vdc**

Pag. VI

**DALI 2**

Pag. VI

**SENSOR**

Pag. VI



Paletto per l'illuminazione di giardini o parchi, con effetto di luce discreta.

**Installazione:** a terra

**Corpo:** in alluminio pressofuso UNI EN 1706, verniciato con polvere termoindurente poliestere

**Verniciatura:** di tipo poliestere eseguita a polvere, resistente agli agenti atmosferici e alla corrosione e garantita per 1.000 ore in nebbia salina. Colore Nero RAL 9005.

**Diffusore:** in policarbonato trasparente (che previene efficacemente l'ingiallimento e l'invecchiamento)

**Driver:** incorporato.

**Sorgente:** LED. Fattore di potenza  $\geq 0,9$ . Mantenimento del flusso luminoso al 80%. 50.000h (L80B20)

*Bollard for lighting gardens or parks, with a discreet light effect.*

*Installation: on the ground*

*Body: in UNI EN 1706 die-cast aluminium, painted with polyester thermosetting powder*

*Painting: polyester type made with powder, resistant to atmospheric agents and corrosion and guaranteed for 1,000 hours in salt spray. Color Black RAL 9005.*

*Diffuser: in transparent polycarbonate (which effectively prevents yellowing and ageing)*

*Driver: built-in.*

*Source: LEDs. Power factor  $\geq 0.9$ . Lumen maintenance at 80%. 50.000h (L80B20)*

100-240 Vac	50/60 Hz	IP66	IK09	CRI >80	+50 C -20	850°	
<b>DRIVER INCLUDED</b>		<b>CE</b>					

colour	H mm	W	Optic	K	lm	pcs	Kg	CELL
N	800	15	130°	3000	1125	1	2,80	24300

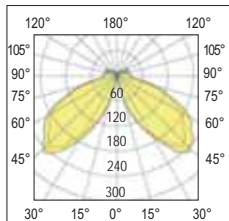

**360°**  
Diffondente - Wide

**Norme di riferimento**

*Standard reference*

- EN60598-1
- EN60598-2-1
- EN62471
- EN62031
- EN60598-2-5
- EN61547

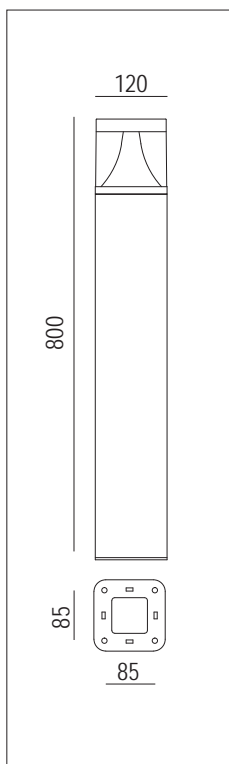

**A richiesta**  
*On demand*

**1-10Vdc**

Pag. VI

**DALI 2**

Pag. VI

**SENSOR**

Pag. VI



Outdoor

# LED Nord



### FAST CONNECTOR

Completo di connettore stagno maschio/femmina IP67 per il collegamento alla linea, di facile installazione.

Complete with IP67 male/female waterproof connector for connection to the line, easy to install.

Paletto per l'illuminazione di giardini e parchi, con effetto di luce discreta.

Illuminazione verso il basso a rispetto della normativa contro l'inquinamento luminoso. Design pratico di facile installazione grazie al cavo presa e spina in dotazione il cablaggio è semplice e immediato, possibilità di scelta del palo in 3 diverse misure (da ordinare separatamente).

**Installazione:** a pavimento

**Corpo:** in alluminio pressofuso UNI EN 1706, verniciato con polvere termoidurente poliesteri

**Verniciatura:** di tipo poliesteri eseguita a polvere, resistente agli agenti atmosferici e alla corrosione e garantita per 1.000 ore in nebbia salina. Colore Antracite.

**Diffusore:** in policarbonato opalino infrangibile ed autoestinguente V2, stabilizzato ai raggi UV.

**Driver:** incorporato

**Sorgente:** LED **CREE**  Fattore di potenza  $\geq 0,90$ . Mantenimento del flusso luminoso al 80%. 50.000h (L80B20)

*Bollard for lighting private gardens or parks, with diffused, discreet and anti-light pollution effect, with a practical design and easy to install thanks to the socket and plug cable provided. The wiring is simple and immediate and the pole comes in 3 different sizes (to be ordered separately).*

*Installation: floor*

*Body: in UNI EN 1706 die-cast aluminium, painted with thermohardening polyester powder*  
*Painting: powder polyester coating, resistant to atmospheric agents and corrosion and guaranteed for 1,000 hours in salt spray. Colour: Anthracite.*

*Diffuser: in V2 self-extinguishing and shatter-proof opal polycarbonate, UV stabilised.*

*Driver: built-in*

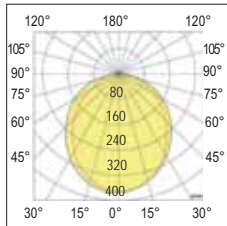
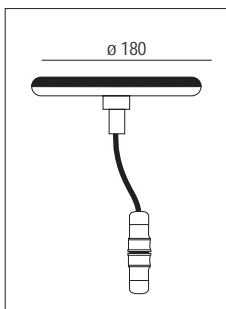

*Source: CREE LED. Power factor  $\geq 0.90$ . Maintenance of 80% luminous flux. 50.000h (L80B20).*



180°  
Diffondente - Wide

### Norme di riferimento Standard reference

- EN60598-1
- EN60598-2-1
- EN62471
- EN62031
- EN60598-2-5
- EN61547

220-240 Vac	50/60 Hz	IP65	IK09	CRI >80	+40 °C -20		850° 	
----------------	-------------	------	------	------------	------------------	--	---	--



colour	Ø mm	W	Optic	K	lm	pcs	Kg	CELL
A	180	10	120°	3000	720	1	0,8	25000

Outdoor





**Accessori non inclusi - Not included accessories**

colour	H mm	Description	CELL
A	380	Paolo Ø 40mm Pole Ø 40mm	25000/PAL38
A	750		25000/PAL75
A	1100		25000/PAL110

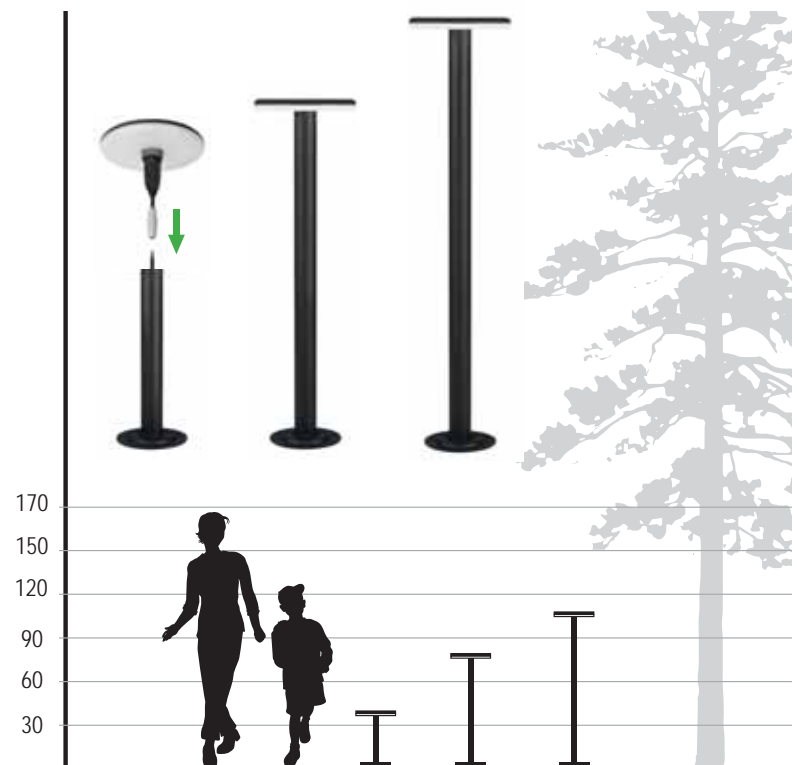
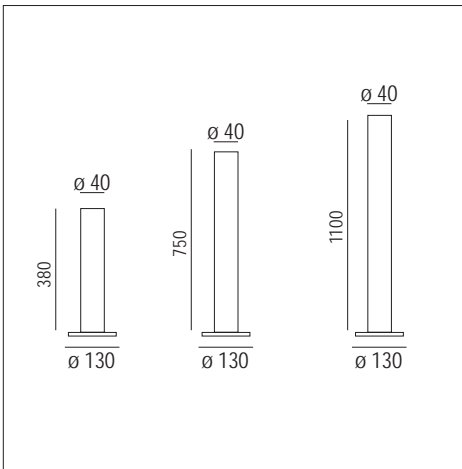

# LED Maga

**3in1**



Apparecchi di illuminazione a LED installazione fissa a parete o soffitto che trovano la propria corretta applicazione dove è richiesto un punto luce con emissione con angolo flood solo verso il basso oppure verso alto e basso. L'accurata scelta dei materiali ed i trattamenti superficiali contro la corrosione eseguiti su ogni componente rendono gli apparecchi adatti a qualsiasi condizione di utilizzo in ambienti esterni.

**Corpo:** in lega di alluminio pressofuso verniciato e altamente resistente alla corrosione.

**Verniciatura:** di tipo poliestere eseguita a polvere, resistente agli agenti atmosferici e alla corrosione e garantita per 1.000 ore in nebbia salina.

**Colore:** Nero RAL 9005 (LED Maga W e LED Maga C) - Bianco RAL 9003 (solo LED Maga C).

**Staffa a muro:** alluminio pressofuso EAN46100. Verniciatura di tipo poliestere, eseguita a polvere

**Schermo:** vetro borosilicato H.4mm. extra chiaro resistente agli shock termici e agli urti

Driver: incorporato

**Sorgente:** LED **CREE**, mantenimento del flusso luminoso minimo al 80%: 50.000h (L80B10)

*Outdoor LED lighting fixtures for fixed installation on the wall or ceiling, suitable when a light source is needed with a flood angle emission only downwards or upwards and downwards. The careful choice of materials and surface treatments against corrosion performed on each component make the fixture suitable for any outdoor environment use.*

*Housing: made by UNI 5076 die-cast aluminum, coated with polyester thermoset powder*

*Coating: coated with powdered polyester, resistant to atmospheric agents, corrosion and guaranteed for 1.000 hours in saline mist.*

*Colour: Black RAL 9005 color (LED Maga W and LED Maga C) - White RAL 9003 color (only LED Maga C).*

*Wall bracket: EAN46100 die-cast aluminium. Painting: powder polyester coating.*

*Screen: extra-light borosilicate glass resistant to thermal shocks and impacts (satin-finish upon request)*

*Driver: included*

*Source: LED **CREE**, maintenance of 80% minimum luminous flux: 50,000h (L80B10)*

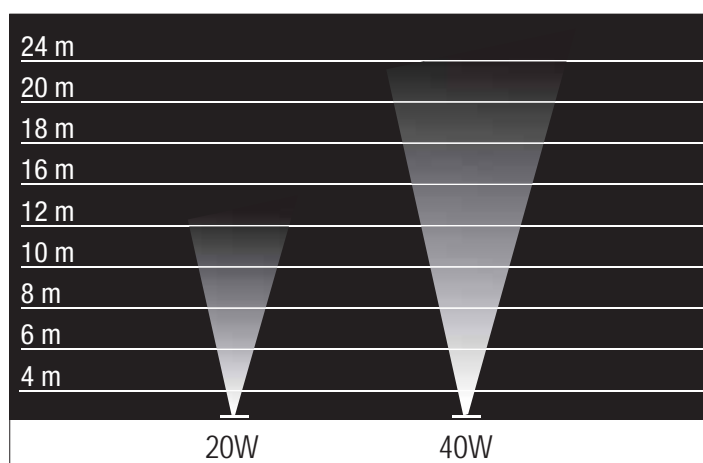
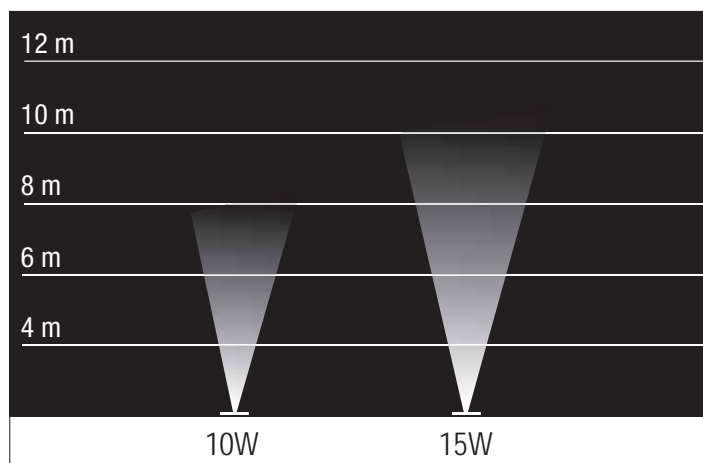

Outdoor

# LED Maga W UP & DOWN - Ø 110mm - Ø 144mm



220-240  
Vac

50/60  
Hz

IP66

IK08

CRI  
>80

+40  
C  
-20

⊕

850°

✂

↻

DRIVER INCLUDED

CE

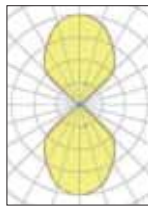

colour	W	Optic	K			lm	pcs	Kg	CELL
N	2x20	80°	4000			2x1900	1	1,40	32323
N	2x20	80°	3000			2x1900	1	1,40	32323-10
N	2x20	80°	3000	4000	5000	2x1900	1	1,40	32323-3CCT
N	2x10	80°	3000			2x950	1	1,20	32323-3K

3CCT  
SWITCHABLE

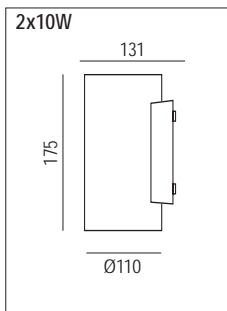
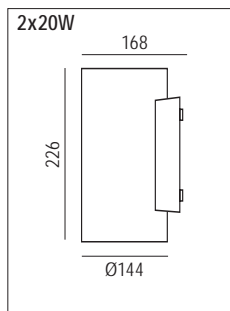

Outdoor



# LED Maga W - Ø 110mm - Ø 144mm



220-240 Vac
50/60 Hz
IP66
IK08
CRI >80
+40°C / -20°C
850°
850°
DRIVER INCLUDED

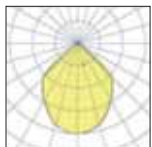

colour	W	Optic	K			lm	pcs	Kg	CELL
N	20	80°	4000			1900	1	1,40	32313
N	20	80°	3000			1900	1	1,40	32313-10
N	10	80°	3000			950	1	1,20	32313-3K
N	10	80°	3000	4000	5000	950	1	1,20	32313-103CCT

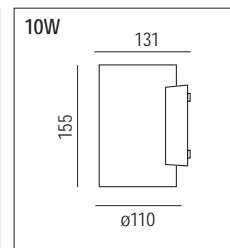
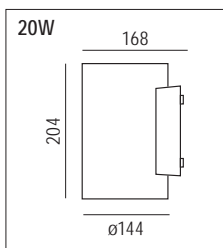

Outdoor



# LED Maga C (Ø 126mm / Ø 168mm)



220-240 Vac	50/60 Hz	IP66	IK08	CRI >80	+40°C -20°C	850°	DRIVER INCLUDED
-------------	----------	------	------	---------	----------------	------	-----------------

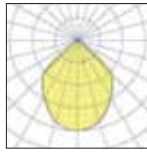

colour	W	Optic	K			lm	pcs	Kg	CELL
N	15	100°	3000			1425	1	1,10	32299/3K
N	15	100°	3000	4000	5000	1425	1	1,10	32299-3CCT
B	15	100°	3000			1425	1	1,10	32299/3K/WH
N	40	100°	4000			3800	1	1,10	32322
N	40	100°	3000			3800	1	1,10	32322/3K

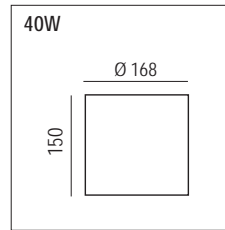
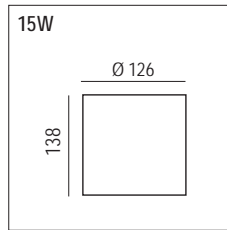

Funzione 3 CCT (3000K - 4000K - 5000K)  
 modificabile con interruttore a cursore  
 Slide switch 3 CCT (3000K - 4000K - 5000K)  
 changeable function



Outdoor



**3in1**





# LED Asso Round

LED Asso Round è un'applicazione a LED dal design cilindrico.

**Corpo:** il corpo è in alluminio e impermeabile

**Diffusore:** policarbonato satinato con rivestimento UV, resistente ai raggi UV.

**Verniciatura:** di tipo poliestere eseguita a polvere, resistente agli agenti atmosferici e alla corrosione e garantita per 1.000 ore in nebbia salina.

Colore Nero RAL 9005 o bianco RAL9016

L'angolo del fascio di 360 gradi può fornire prestazioni di illuminazione brillanti.

Solo la direzione della luce verso l'alto e la direzione della luce verso l'alto e verso il basso per l'opzione. È materiale

Dimmerabile con dimmer TRIAC.

**Norme di riferimento:** EN60598-1; EN60598-2-1; EN62471; EN62031; EN60598-2-5; EN61547

LED Asso Round is a cylindrical design LED wall light.

**Body:** The body is made of aluminum and waterproof

**Diffuser:** UV coated satin polycarbonate, UV resistant.

**Painting:** polyester powder type, resistant to atmospheric agents and corrosion and guaranteed for 1,000 hours in saline mist.

Color Black RAL 9005 or white RAL9016

The 360 degree beam angle can provide brilliant lighting performance.

Only the direction of the light upwards and the direction of the light upwards and downwards for the option. It is material

Dimmable with TRIAC dimmer.

**Reference number:** EN60598-1; EN60598-2-1; EN62471; EN62031; EN60598-2-5; EN61547

# LED Asso Round



220-240 Vac	50/60 Hz	IP65	IK08	CRI >80	+40°C -20°C	750°	750°	DRIVER INCLUDED
-------------	----------	------	------	---------	----------------	------	------	-----------------



colour	W	Optic	K			lm	pcs	Kg	CELL
<b>N</b>	8	170°	3000	4000	5700	670	1	0,90	RL28C76BL8WP3
<b>B</b>	8	170°	3000	4000	5700	670	1	0,90	RL28C76WH8WP3

3 CCT SWITCHABLE

3 CCT SWITCHABLE

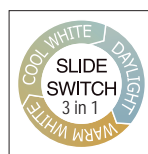
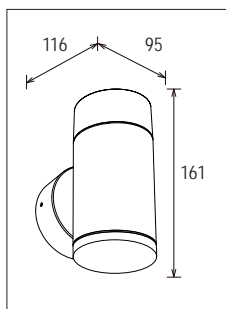

Funzione 3 CCT (3000K - 4000K - 5700K) modificabile con interruttore a cursore

Slide switch 3 CCT (3000K - 4000K - 5700K) changeable function



Regolabile con dimmer a TRIAC  
Dimmable with TRIAC dimmer

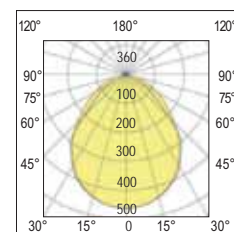

170°  
Diffondente - Diffusing

Outdoor

# LED Asso Round Up & Down



220-240 Vac	50/60 Hz	IP65	IK08	CRI >80	+40°C -20°C	750°	750°	DRIVER INCLUDED
-------------	----------	------	------	---------	----------------	------	------	-----------------



colour	W	Optic	K			lm	pcs	Kg	CELL
<b>N</b>	2x4	170°	3000	4000	5700	670	1	0,90	RL28B76BL8WP3
<b>B</b>	2x4	170°	3000	4000	5700	670	1	0,90	RL28B76WH8WP3

3 CCT SWITCHABLE

3 CCT SWITCHABLE

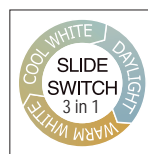
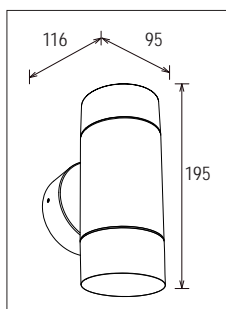

Funzione 3 CCT (3000K - 4000K - 5700K) modificabile con interruttore a cursore

Slide switch 3 CCT (3000K - 4000K - 5700K) changeable function



Regolabile con dimmer a TRIAC  
Dimmable with TRIAC dimmer

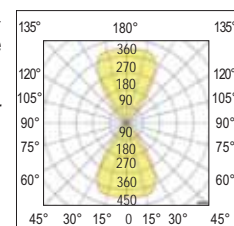

170°  
Diffondente - Diffusing

**3in1**



# LED Asso Square Down - LED Asso Square Up & Down

Appliche ideale per illuminare ingressi o facciate e elementi architettonici.

**Installazione:** soffitto o parete

**Corpo e telaio:** in alluminio pressofuso UNI EN 1706 verniciato con polvere termoindurente poliester

**Diffusore:** policarbonato satinato con rivestimento UV, resistente ai raggi UV.

**Verniciatura:** di tipo poliester eseguita a polvere, resistente agli agenti atmosferici e alla corrosione e garantita per 1.000 ore in nebbia salina. Colore Nero RAL 9005 o bianco RAL9016

**Driver:** incorporato

**Sorgente:** LED SMD

Doppio ingresso Loop In/Out e terminale rapido per una rapida installazione

CCT intercambiabile (3000K + 4000K + 5700K) con interruttore a scorrimento

Ideal wall lamp to illuminate entrances or facades and architectural elements.

**Installation:** ceiling or wall

**Body and frame:** die-cast aluminum UNI EN 1706 painted with polyester thermosetting powder

**Diffuser:** UV coated satin polycarbonate, UV resistant.

**Painting:** polyester powder type, resistant to atmospheric agents and corrosion and guaranteed for 1,000 hours in saline mist. Color Black RAL 9005 or white RAL9016

**Driver:** built-in

**Source:** LED SMD

Double Loop In / Out input and quick terminal for quick installation

Interchangeable CCT (3000K + 4000K + 5700K) with slide switch

## LED Asso square



220-240 Vac	50/60 Hz	IP65	IK08	CRI >80	+45°C -20°C	750°	DRIVER INCLUDED	CE
-------------	----------	------	------	---------	----------------	------	-----------------	----

colour	W	Optic	Lm	K			pcs	Kg	CELL
<b>N</b>	4	120°	450	3000	4000	5700	1	0,64	RL113BL4WP3
<b>B</b>	4	120°	450	3000	4000	5700	1	0,64	RL113WH4WP3

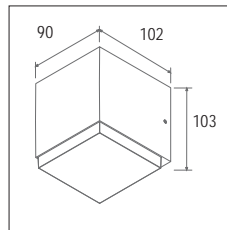

Funzione 3 CCT (3000K - 4000K - 5700K) modificabile con interruttore a cursore

Slide switch 3 CCT (3000K - 4000K - 5700K) changeable function

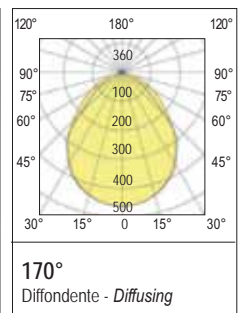

## LED Asso square Up & Down

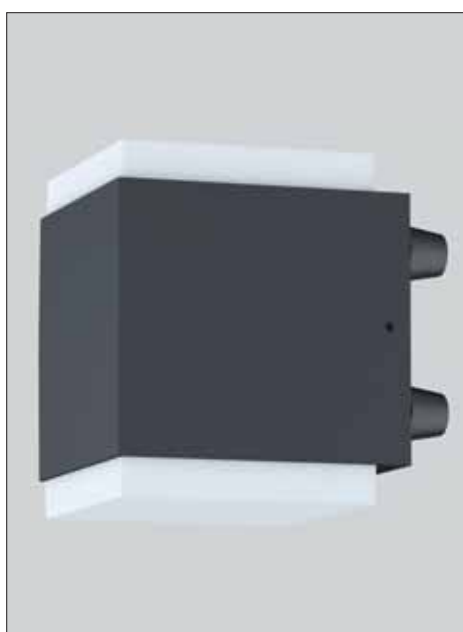

220-240 Vac	50/60 Hz	IP65	IK08	CRI >80	+45°C -20°C	750°	DRIVER INCLUDED	CE
-------------	----------	------	------	---------	----------------	------	-----------------	----

colour	W	Optic	Lm	K			pcs	Kg	CELL
<b>N</b>	2x4	120°	900	3000	4000	5700	1	0,56	RL113CBL4WP3
<b>B</b>	2x4	120°	900	3000	4000	5700	1	0,56	RL113CWH4WP3

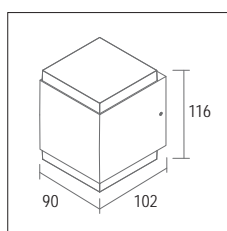

Funzione 3 CCT (3000K - 4000K - 5700K) modificabile con interruttore a cursore

Slide switch 3 CCT (3000K - 4000K - 5700K) changeable function

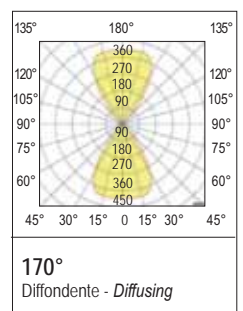

Outdoor



## LED Su & Giù



Appliche ideale per illuminare ingressi o facciate e elementi architettonici.

**Installazione:** a parete

**Corpo e telaio:** in alluminio pressofuso UNI EN 1706 verniciato con polvere termoindurente poliestere

**Verniciatura:** di tipo poliestere eseguita a polvere, resistente agli agenti atmosferici e alla corrosione e garantita per 1.000 ore in nebbia salina. Colore Nero RAL 9005 o Bianco RAL 9003

**Ottica:** regolabile solo per il modello Su & Giù. Per il modello Doppio Su & Giù l'ottica non è regolabile

**Driver:** incorporato

**Sorgente:** LED **CREE** ◀ mantenimento del flusso luminoso minimo al 80%: 50.000h (L80B10).

*Wall luminaire made by die-cast aluminum perfect to light up facades and architectural elements.*

**Installation:** wall use

**Housing and frame:** made by UNI EN 1706 die-cast aluminum, coated with polyester thermoset powder

**Coating:** coated with powdered polyester, resistant to atmospheric agents, corrosion and guaranteed for 1.000 hours in saline mist. Black RAL9005 or Whitr RAL 9003

**Optic:** adjustable only for the Up & Down model. For the Double Up & Down model, the optics are not adjustable

**Driver:** included

**Light source:** LED **CREE** ◀ maintenance of 80% minimum luminous flux: 50,000h (L80B10).

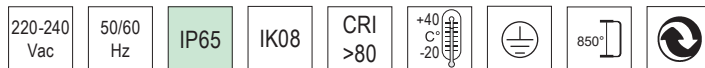

colour	W	K			lm	pcs	Kg	CELL
<b>N</b>	9	2700	3000	4000	1500	1	1,50	32292-3CCT
<b>B</b>	9	2700	3000	4000	1500	1	1,50	32291-3CCT

3CCT SWITCHABLE

3CCT SWITCHABLE

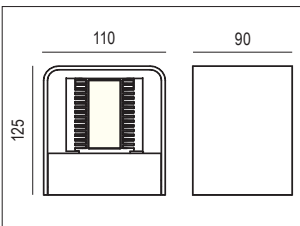

**Norme di riferimento**  
**Standard reference**

EN60598-1  
EN60598-2-1  
EN62471  
EN62031  
EN60598-2-5  
EN61547

Outdoor

**Alette orientabili per l'emissione della luce con diverse inclinazioni - Adjustable fins to allow the emission of light with different inclinations**

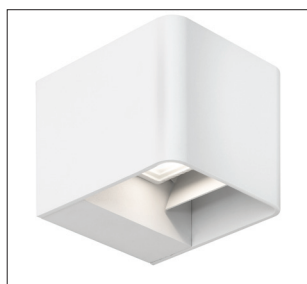

## LED Doppio Su & Giù

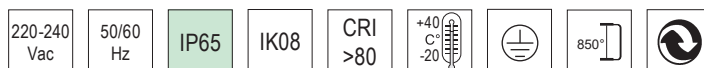

colour	W	K			lm	pcs	Kg	CELL
<b>N</b>	18	2700	3000	4000	1500	1	1,50	32292-23CCT

3CCT SWITCHABLE

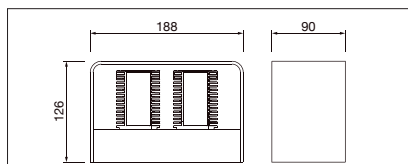











# LED Micro Solo Giù Round - LED Medio Solo Giù Square

Plafoniera a LED idonea per applicazioni civili per l'illuminazione di camminamenti residenziali, spazi commerciali o alberghieri.

Le linee quadrate e circolari semplici combinate con la sorgente di luce a LED indiretta possono creare un ambiente di illuminazione bello e morbido.

L'applicazione può essere utilizzata sia in ambienti interni che esterni.

**Corpo:** realizzato in lega di alluminio ad alta resistenza e resistente ai raggi UV.

**Diffusore:** in vetro temprato 4mm

**Colore:** Nero RAL9005 o Bianco RAL9016

**Installazione:** a parete

**Verniciatura:** di tipo poliestere eseguita a polvere, resistente agli agenti atmosferici e alla corrosione

**Norme di riferimento:** EN60598-1; EN60598-2-1; EN62471; EN62031; EN60598-2-5; EN61547

*LED ceiling light suitable for civil applications for the lighting of residential walkways, commercial or hotel spaces.*

*Simple square and circular lines combined with indirect LED light source can create a beautiful and soft lighting environment.*

*The wall lamp can be used both indoors and outdoors.*

*Body: made of high strength and UV resistant aluminum alloy.*

*Diffuser: in 4mm tempered glass*

*Color: Black RAL9005 or White RAL9016*

*Installation: on the wall*

*Painting: polyester powder type, resistant to atmospheric agents and corrosion*

*Reference number: EN60598-1; EN60598-2-1; EN62471; EN62031; EN60598-2-5; EN61547*

## LED Micro Solo Giù Round



200-240 Vac	50/60 Hz	IP65	IK08	CRI >80	+45°C -20°C	750°	DRIVER INCLUDED	CE	
-------------	----------	------	------	---------	----------------	------	-----------------	----	--

colour	W	Optic	K	lm	pcs	Kg	CELL
<b>N</b>	5	ASY	3000	170	1	0,33	RLRO59A5W3KBL
<b>B</b>	5	ASY	3000	170	1	0,33	RLRO59A5W3KWH

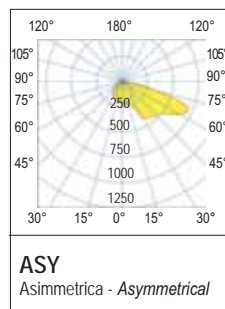
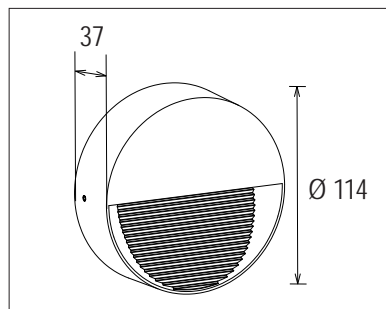

Outdoor

## LED Medio Solo Giù Square



200-240 Vac	50/60 Hz	IP65	IK08	CRI >80	+45°C -20°C	750°	DRIVER INCLUDED	CE	
-------------	----------	------	------	---------	----------------	------	-----------------	----	--

colour	W	Optic	K	lm	pcs	Kg	CELL
<b>N</b>	5	ASY	3000	170	1	0,39	RLSQ59A5W3KBL
<b>B</b>	5	ASY	3000	170	1	0,39	RLSQ59A5W3KWH

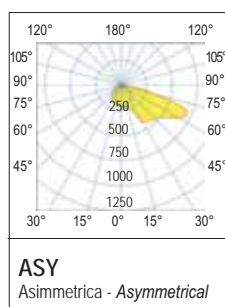
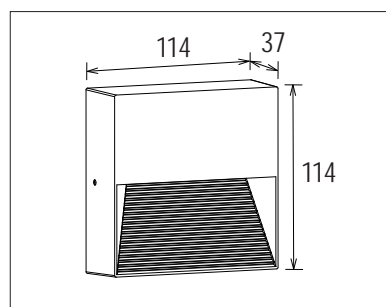

# LED Sologìù R - LED Sologìù S

Plafoniera a LED idonea per applicazioni civili per l'illuminazione di camminamenti residenziali, spazi commerciali o alberghieri.

**Installazione:** a parete

**Corpo:** in alluminio pressofuso UNI EN 1706, verniciato con polvere termoindurente poliestere

**Verniciatura:** di tipo poliestere eseguita a polvere, resistente agli agenti atmosferici e alla corrosione e garantita per 1.000 ore in nebbia salina. Colore Antracite RAL7024.

**Diffusore:** in vetro temperato piano extrachiario.

**Cablaggio:** con doppio ingresso cavi.

**Sorgente:** LED **SAMSUNG** mantenimento del flusso luminoso minimo al 80%: 50.000h (L80B10).

LED ceiling light suitable for civil applications for the lighting of residential walkways, commercial or hotel spaces.

**Installation:** wall mounting

**Housing:** made by UNI EN 1706 die-cast aluminum, coated with polyester thermoset powder

**Coating:** coated with powdered polyester, resistant to atmospheric agents, corrosion and guaranteed for 1.000 hours in saline mist. Anthracite color RAL7024.

**Diffuser:** in extra-clear flat tempered glass.

**Wiring:** with double cable entry.

**Light source:** LED **SAMSUNG** maintenance of 80% minimum luminous flux: 50,000h (L80B10).

220-240 Vac	50/60 Hz	IP65	IK06	+40 C° -20		850°		CE	DRIVER INCLUDED 	
----------------	-------------	------	------	------------------	--	------	--	----	---------------------	--

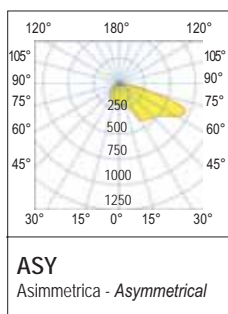
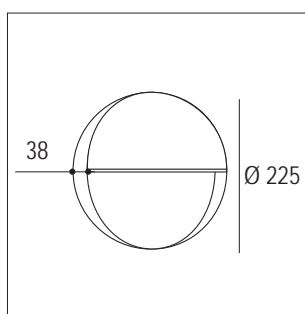

LED Sologìù R							
colour	W	Optic	K	lm	pcs	Kg	CELL
A	8,5	ASY	3000	300	1	0,8	SOLOGIUR

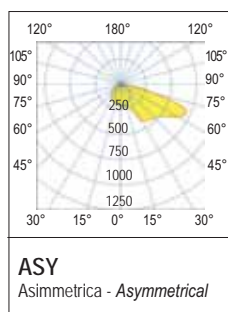
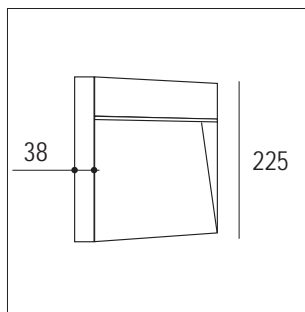

LED Sologìù S							
colour	W	Optic	K	lm	pcs	Kg	CELL
A	8,5	ASY	3000	300	1	0,8	SOLOGIUS



Outdoor

# LED Mole

La lampada da parete LED Mole è un design di illuminazione up & down

**Corpo:** in alluminio pressofuso per un'eccellente dissipazione termica. la superficie della lampada è spruzzata con polvere di granelli di sabbia per esterni, resistente alla corrosione

**Diffusore:** in vetro temprato 4mm

**Verniciatura:** Nero RAL 9005 o Bianco RAL 9016 (anti corrosione e resistente agli agenti atmosferici)

**Sorgente:** LED SMD

**Installazione:** a parete sia per interno che per esterno

**Alimentazione:** inclusa

Il design della struttura robusta, l'impermeabilità IP65 si adatta a un'area di applicazione più ampia.

*The Mole LED wall lamp is an up & down lighting design*

***Body:** in die-cast aluminum for excellent heat dissipation. The surface of the lamp is sprayed with outdoor sand grain powder, corrosion resistant*

***Source:** SMD LED*

***Diffuser:** in 4mm tempered glass*

***Paint:** Black RAL 9005 or White RAL 9016 (corrosion and weather resistant)*

***Installation:** one wall for both indoor and outdoor*

***Power supply:** included*

*Rugged structure design, IP65 waterproofing suits larger application area.*



220-240 Vac	50/60 Hz	IP65	IK07	+45 C° -20		750°	
----------------	-------------	------	------	------------------	--	------	--



colour	W	Optic	Lm	K			pcs	Kg	CELL
N	10	180°	700	3000	4000	5700	1	0,71	RL88-10W-BL3P
B	10	180°	700	3000	4000	5700	1	0,71	RL88-10W-WH3P

3 CCT  
SWITCHABLE

3 CCT  
SWITCHABLE

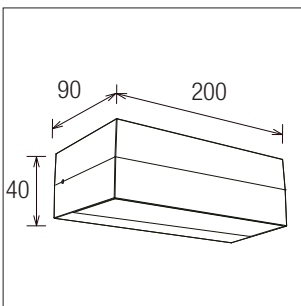

Funzione 3 CCT (3000K - 4000K - 5700K) modificabile con interruttore a cursore

Slide switch 3 CCT (3000K - 4000K - 5700K) changeable function

Regolabile con dimmer a TRIAC o IGBT

Dimmable with TRIAC or IGBT dimmer

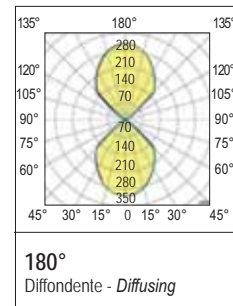

Interruttore a cursore a 3 posizioni per selezionare la direzione luminosa  
3-position slider switch to select the light direction



Outdoor





# LED Up & Down

Plafoniera a LED idonea per applicazioni civili per l'illuminazione di camminamenti residenziali, spazi commerciali o alberghieri.

Per utilizzo in indoor e outdoor.

**Installazione:** a parete

**Corpo:** realizzato in alluminio pressofuso.

**Vetro:** temperato opalino, ad elevato comfort visivo e distribuzione luminosa uniforme.

**Verniciatura:** di tipo poliestere eseguita a polvere, resistente agli agenti atmosferici e alla corrosione e garantita per 1.000 ore in nebbia salina. Colore Nero RAL 9005

**Driver:** incorporato

Nessun rischio fotobiologico, secondo EN 62471:2008.

La massima temperatura superficiale di tutte le parti accessibili sotto i 50 gradi per sicurezza e affidabilità.

**Sorgente:** LED. Mantenimento del flusso luminoso minimo al 80%: 50.000h (L80B10)

*LED ceiling light suitable for civil applications for lighting residential walkways, commercial spaces or hotels..*

*The applique can be used both indoors and outdoors.*

*Installation: on the wall*

*Body: made of die-cast aluminium.*

*Glass: opal tempered, with high visual comfort and uniform light distribution.*

*Painting: polyester type made with powder, resistant to atmospheric agents and corrosion and guaranteed for 1,000 hours in salt spray. Color Black RAL 9005*

*Drivers: included*

*No photobiological risk, according to EN 62471:2008.*

*Maximum surface temperature of all accessible parts below 50 degrees for safety and reliability.*

*Source: LEDs. Minimum luminous flux maintenance at 80%: 50,000h (L80B10)*



220-240  
Vac

50/60  
Hz

IP65

IK08



DRIVER INCLUDED

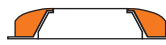

colour	W	Optic	Lm	K	pcs	Kg	CELL
N	30	100°	4500	3000	1	1,00	SUGIU363K
N	30	100°	4500	4000	1	1,00	SUGIU364K
N	30	100°	4500	3000	1	1,00	SUGIU363KD
N	30	100°	4500	4000	1	1,00	SUGIU364KD

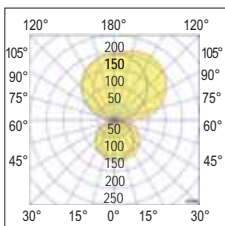
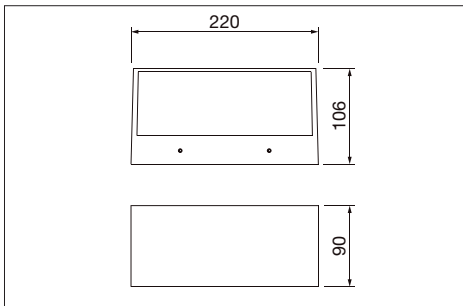

Norme di riferimento  
*Standard reference*

EN60598-1  
EN60598-2-1  
EN62471  
EN62031  
EN60598-2-5  
EN61547

100°  
Diffondente - *Wide*



Outdoor

## LED Lodi Giù (installazione incasso o parete - built-in or wall installation)

Outdoor

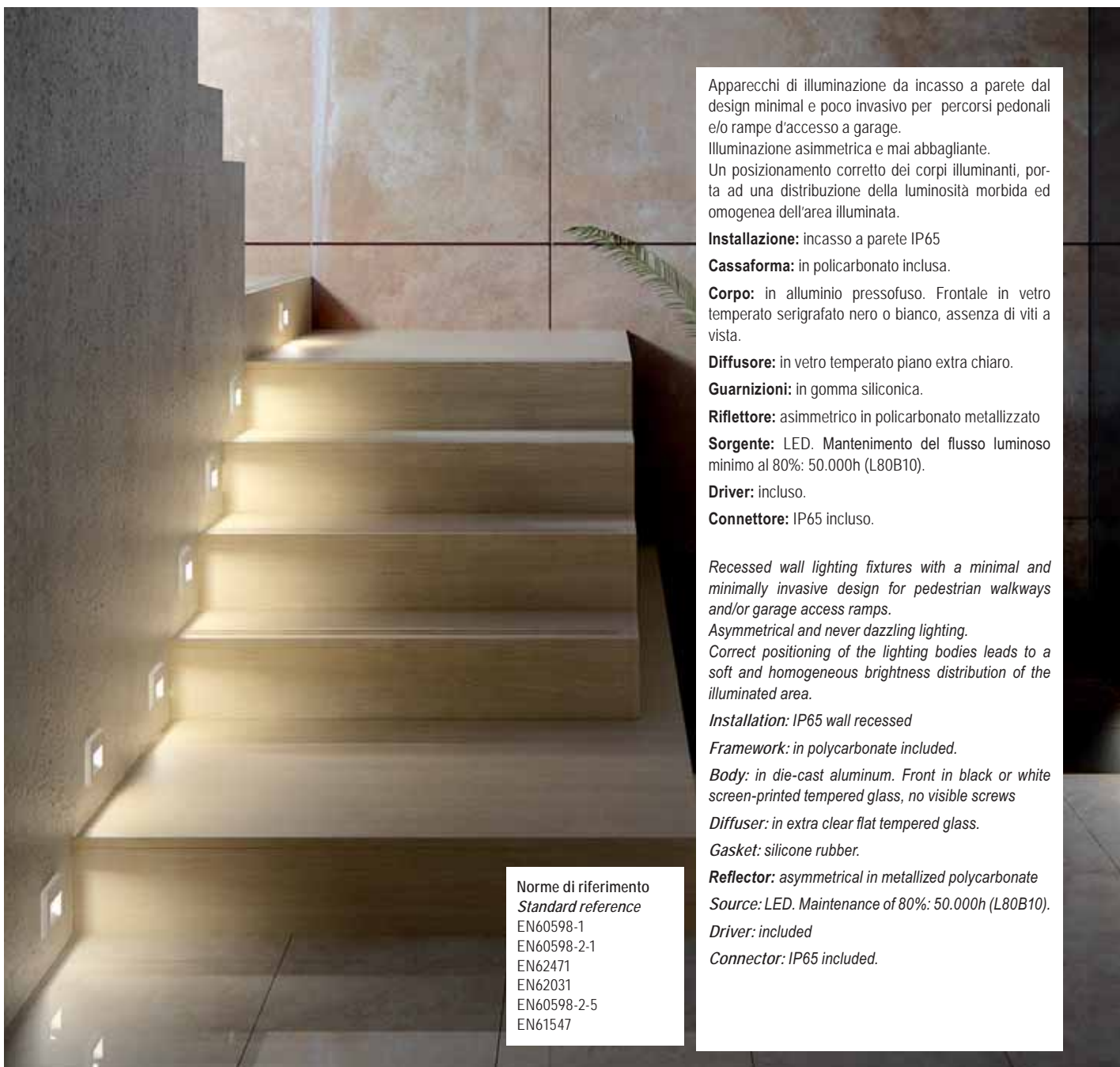

Norme di riferimento  
Standard reference  
EN60598-1  
EN60598-2-1  
EN62471  
EN62031  
EN60598-2-5  
EN61547

Apparecchi di illuminazione da incasso a parete dal design minimal e poco invasivo per percorsi pedonali e/o rampe d'accesso a garage.

Illuminazione asimmetrica e mai abbagliante.

Un posizionamento corretto dei corpi illuminanti, porta ad una distribuzione della luminosità morbida ed omogenea dell'area illuminata.

**Installazione:** incasso a parete IP65

**Cassaforma:** in policarbonato inclusa.

**Corpo:** in alluminio pressofuso. Frontale in vetro temperato serigrafato nero o bianco, assenza di viti a vista.

**Diffusore:** in vetro temperato piano extra chiaro.

**Guarnizioni:** in gomma siliconica.

**Riflettore:** asimmetrico in policarbonato metallizzato

**Sorgente:** LED. Mantenimento del flusso luminoso minimo al 80%: 50.000h (L80B10).

**Driver:** incluso.

**Connettore:** IP65 incluso.

*Recessed wall lighting fixtures with a minimal and minimally invasive design for pedestrian walkways and/or garage access ramps.*

*Asymmetrical and never dazzling lighting.*

*Correct positioning of the lighting bodies leads to a soft and homogeneous brightness distribution of the illuminated area.*

*Installation: IP65 wall recessed*

*Framework: in polycarbonate included.*

*Body: in die-cast aluminum. Front in black or white screen-printed tempered glass, no visible screws*

*Diffuser: in extra clear flat tempered glass.*

*Gasket: silicone rubber.*

*Reflector: asymmetrical in metallized polycarbonate*

*Source: LED. Maintenance of 80%: 50.000h (L80B10).*

*Driver: included*

*Connector: IP65 included.*





# LED Lodi Giù



220-240 Vac	110 Vac a richiesta on demand	50/60 Hz	IP65	IK06	CE
-------------	-------------------------------	----------	------	------	----

	850°		CRI >80	+40 C -20	
--	------	--	---------	-----------	--



colour	W	Optic	K	lm	pcs	Kg	CELL
N	1,5	ASY	3000	70	1	0,7	29091
B	1,5	ASY	3000	70	1	0,7	29090
N	2,5	ASY	3000	130	1	0,7	29093
B	2,5	ASY	3000	130	1	0,7	29092
N	3,5	ASY	3000	190	1	0,7	29095
B	3,5	ASY	3000	190	1	0,7	29094

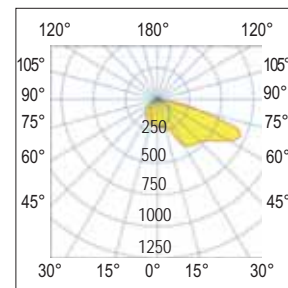
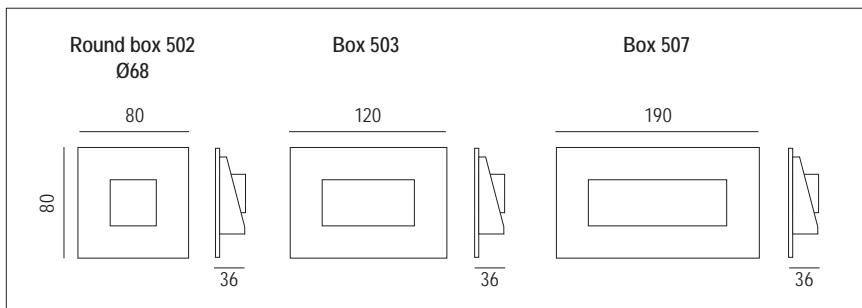

**ASY**  
Asimmetrica - Asymmetrical

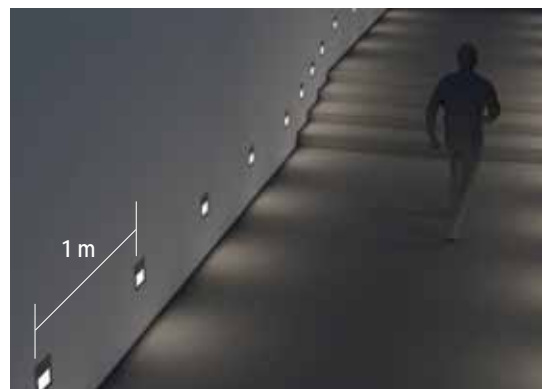

Outdoor

## Accessori NON inclusi - NOT included accessories

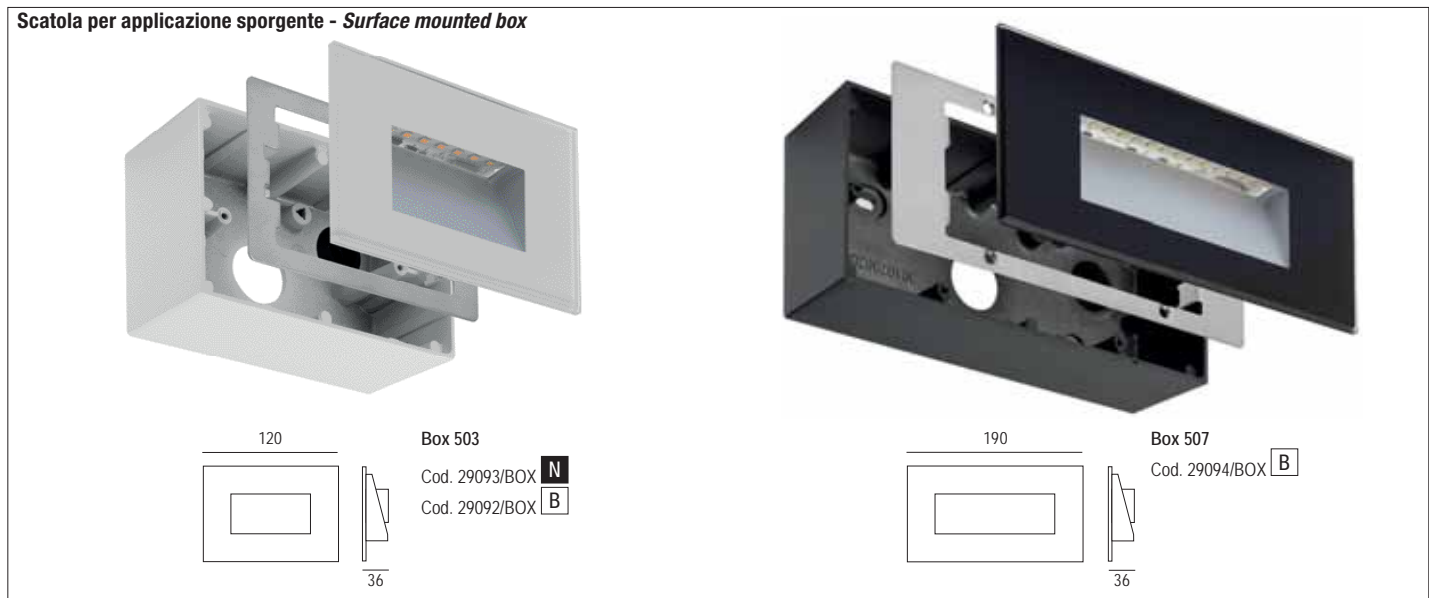

# LED Turbot

L'appliche LED Turbot ha un design su e giù con driver interno

**Corpo:** in alluminio pressofuso per un'eccellente dissipazione termica

**Verniciatura:** Nero RAL 9005 o Bianco RAL 9016 (anti corrosione e resistente agli agenti atmosferici)

**Diffusore:** policarbonato con rivestimento UV, resistente ai raggi UV.

**Installazione:** a plafone o parete sia per interno che per esterno

**Alimentazione:** inclusa

*Turbot LED wall light has an up and down design with internal driver*

**Body:** in die-cast aluminum for excellent heat dissipation

**Paint:** Black RAL 9005 or White RAL 9016 (corrosion and weather resistant)

**Diffuser:** UV coated polycarbonate, UV resistant.

**Installation:** surface or wall mounted for both indoor and outdoor

**Power supply:** included



100-240 Vac	50/60 Hz	IP65	IK10	+45 C° -20	
750°		CE	<b>DRIVER INCLUDED</b>		

colour	W	Optic	K	Lm	pcs	Kg	CELL
<b>N</b>	8	180°	3000	600	1	0,42	RL08-8W-BL3K
<b>B</b>	8	180°	3000	600	1	0,42	RL08-8W-WH3K

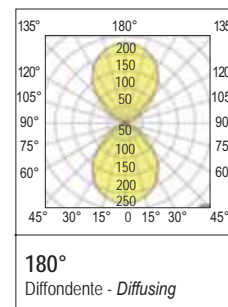
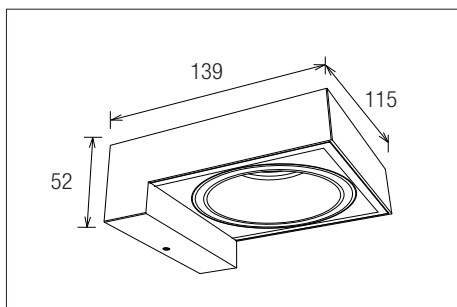

Outdoor



# LED Line Up

illuminazione che disegna l'architettura con fasci di luce mettendo in evidenza vuoti e pieni che ne enfatizzano la tridimensionalità degli spazi.

La luce interagendo con la materia crea ambienti nuovi che di giorno non esistono

Il corpo illuminante tende a scomparire per le sue ridotte dimensioni

**Installazione:** parete o soffitto

**Corpo e telaio:** schermo in polimetacrilato, corpo in alluminio pressofuso

**Driver:** incluso

*Light designs architecture with beams of light highlighting empty and full that emphasize the three-dimensionality of spaces.*

*Light interacting with matter creates new rooms that do not exist during the day*

*The lighting body tends to disappear thanks to its small sizes*

*Installation: Wall and ceiling mounted*

*Body and frame: polymerised acrylic screen, die-cast aluminum body*

*Driver: driver included*



220-240 Vac	50/60 Hz	IP55	IK08	CRI >80	+45 °C -20	
75°		CE	DRIVER INCLUDED			

colour	W	Optic	K	lm output	pcs	Kg	CELL
N	6	180°	4000	270	1	0,30	29140
N	6	180°	3000	270	1	0,30	29141

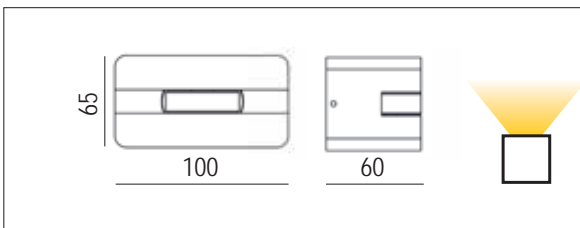

Outdoor



# LED Platax PLUS - XL



Outdoor

## LED Platax PLUS - LED Platax XL

Plafoniera a LED stagna, idonea per applicazioni civili, commerciali, alberghiere.

**Corpo e cornice:** in nylon rinforzato con fibre di vetro, guarnizione in silicone, viti Torx anti-vandalo imperdibili.

**Diffusore:** in policarbonato opale, antiurto ed autoestinguente.

**Cablaggio:** composto da alimentazione 220-240V 50Hz, cavi in PVC HT 105° non propagante la fiamma, doppio isolamento. LED Platax è installabile sia per impianto sotto parete che esterno; fornita di serie con pressacavo in nylon PG13,5.

### Con sensore di movimento LED Platax Eye - LED Platax XL

Plafoniera a LED con sensore ad alta frequenza a 5,8 GHz. Colorazione neutra e gradevole, intensità e tonalità della luce invariate nel tempo. Sensore invisibile estremamente sensibile e silenzioso nell'accensione, con risposta immediata. È possibile regolare la sensibilità di rilevamento, la distanza di intervento, la soglia di luminosità ed il tempo di accensione.

**Sorgente:** LED LUMILEDS 3528

Mantenimento del flusso luminoso minimo al 80% - 80.000h (L80B20).

**Norme di riferimento:** EN60598-1, EN60598.2.1, EN62471, EN62031.

Nessun rischio fotobiologico, RGO gruppo di rischio esente (EN62471).

**Grado IP:** IP65 certificato da laboratorio accreditato

**Prodotto conforme alle direttive:** 

## LED Platax Plus - LED Platax XL

Compact waterproof LED fitting suitable for civil, commercial, hotel applications, etc.

**Body and frame:** made by nylon reinforced with glass fibres, silicone gasket, non-loosening Torx screws.

**Diffuser:** made by shockproof and self-extinguishing opal polycarbonate.

**Wiring:** includes 220-240V 50Hz control gear, non-flame propagating PVC HT 105° cables, double insulated. LED Platax can be installed in both concealed and outdoor circuits; supplied with nylon cable gland RG13,5.

### With motion sensor LED Platax Eye - LED Platax XL

Fitting with 5.8 GHz high-frequency sensor with neutral and pleasant colour, unaltered light intensity over time, extremely sensitive invisible sensor and silent switching-on, with instant response. The detection sensitivity, intervention distance, luminosity threshold and lighting time can be adjusted.

Source: LED LUMILEDS 3528

Maintenance of minimum luminous flux to 80% - 80.000h (L80B20).

**Reference standards:** EN60598-1, EN60598.2.1, EN62471, EN62031.

No risk of photobiological damage, RGO group (EN62471).

**IP degre:** IP65 certified by an external laboratory

**In compliance with the directives:** 

## LED PLATAX PLUS - Accessori - Accessories

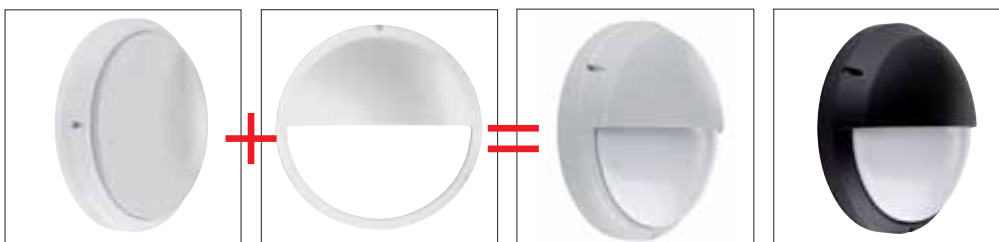

**B** Cod. CO3001.100 - Ø 290mm (Platax plus) Visiera Nylon - Nylon visor

**N** Cod. CO3002.100 - Ø 290mm (Platax plus) Visiera Nylon - Nylon visor

## Dati fotometrici - Photometric data

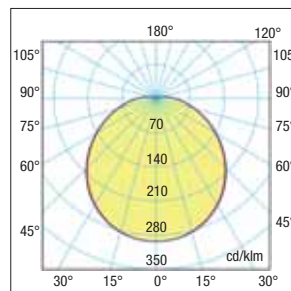

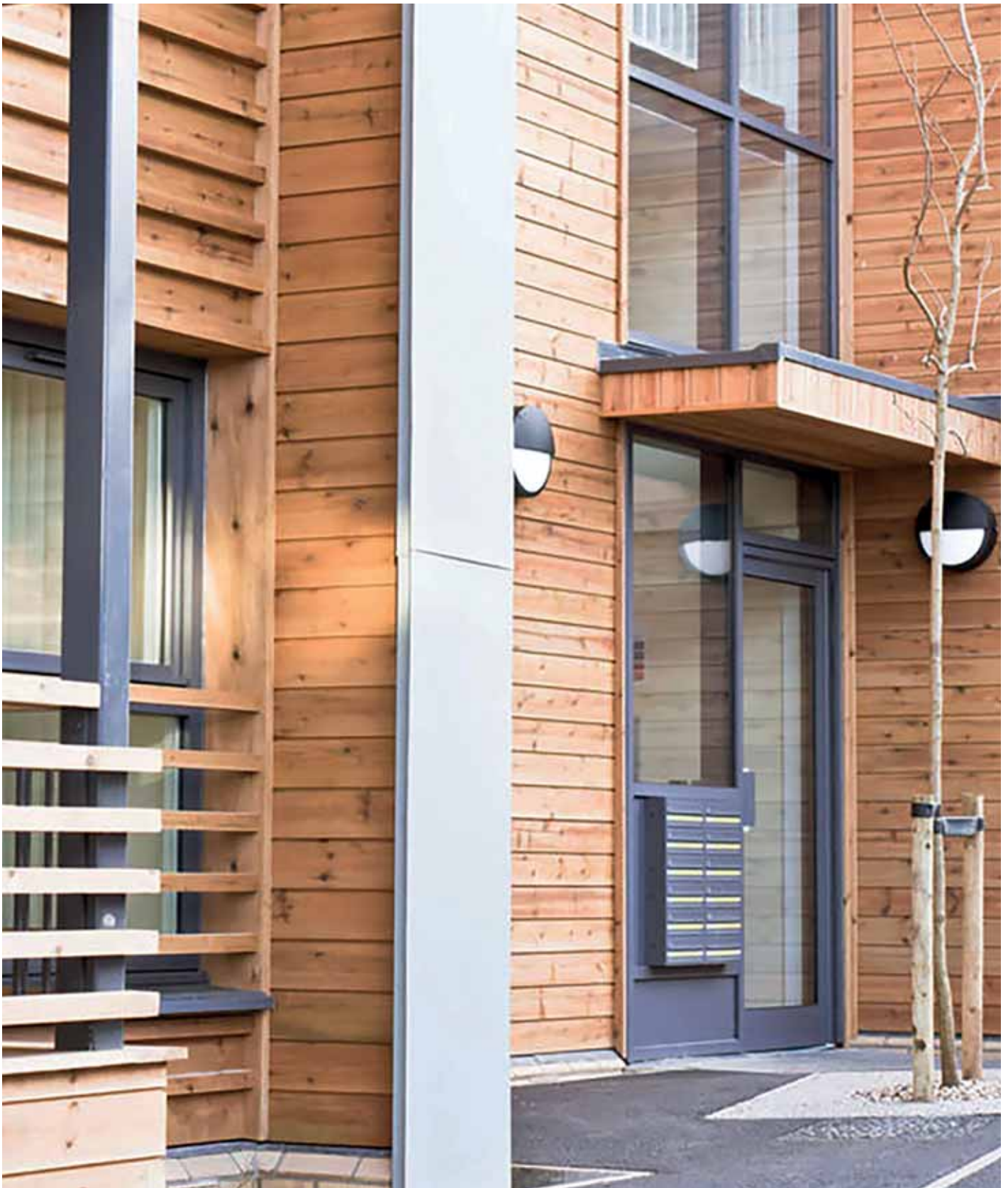

Outdoor

**Taratura driver Platax Plus - Factory setting driver Platax Plus**



Led driver (4 poli Dip-Switch) permette di selezionare la potenza desiderata (1-2-3-4) e scegliere il funzionamento necessario.

LED Driver (4 pole Dip-switches) allows you to select the desired power (1-2-3-4) and to select the required connection.

Impostazione standard di fabbrica  
Driver Standard factory setting

Selezione Dip-Switch <i>Dip-Switch selection</i>				Potenza <i>Power</i>	Lm Output	mA
1	2	3	4	Watt	Lm	mA
•	ON	ON	•	10	750	500
ON	•	ON	•	15	1150	650
ON	ON	ON	•	20	1600	700

# LED Platax PLUS - XL

220-240V 50/60Hz



IK09

IP65

## Led Platax PLUS multipotenza



**CRI 90**

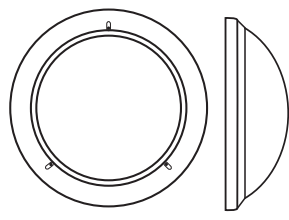

ø280

100



### LED Platax Plus

colour	W	V	Lm output	K	pcs	Kg	CELL
B	11	220-240	1000	4000	006	0,850	555523.0101
B	16	220-240	1400	3000	006	0,850	555638.0101
B	16	220-240	1400	4000	006	0,850	555611.0101

colour	W	V	Lm output	K	pcs	Kg	CELL
B	max 20	220-240	max 1600	3000	006	0,850	555637.PLUS
B	max 20	220-240	max 1600	4000	006	0,850	555523.PLUS
N	max 20	220-240	max 1600	3000	006	0,850	555538.PLUS
N	max 20	220-240	max 1600	4000	006	0,850	555524.PLUS
B	max 20	220-240	max 1600	3000	006	0,850	555637.PLUSDA
B	max 20	220-240	max 1600	4000	006	0,850	555523.PLUSDA

colour	W	V	Lm output	K	pcs	Kg	CELL
B	max 20	220-240	max 1600	3000	006	0,850	555540.PLUS
B	max 20	220-240	max 1600	4000	006	0,850	555613.PLUS
N	max 20	220-240	max 1600	3000	006	0,850	555540.PLUSNE
N	max 20	220-240	max 1600	4000	006	0,850	555613.PLUSNE

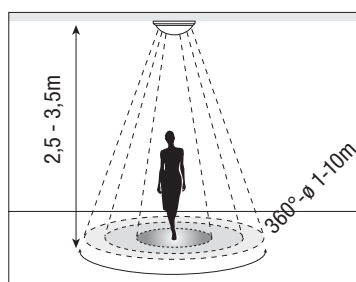
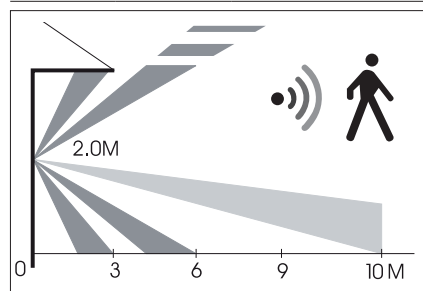

## Led Platax multipower Emer Autotest

### Caratteristiche tecniche

(A) Linea permanente per la ricarica delle batterie e il funzionamento in emergenza.

(B) Linea interrotta.

(D) Il gruppo batterie viene fornito non connesso per non danneggiare gli accumulatori.

Eseguire la connessione durante l'installazione.

### Technical features

(A) Permanent mains supply (battery recharge and mains failure detection).

(B) Non permanent mains.

(D) The battery pack comes not connected to the circuit.

Connect together male and female connectors.

colour	W	V	K	Lm Output	Flux Lm	Kg	CELL-E
B	max 20	220-240	3000	max 1600	15%	1,160	555637.PLUSEM
B	max 20	220-240	4000	max 1600	15%	1,160	555523.PLUSEM
N	max 20	220-240	3000	max 1600	15%	1,160	555568.PLUSEM
N	max 20	220-240	4000	max 1600	15%	1,160	555524.PLUSEM

### LED Platax MULTIPOWER EMER + EYE

colour	W	V	K	Lm Output	Flux Lm	Kg	CELL-E
B	max 20	220-240	3000	max 1600	15%	1,160	555637PLUSEMS
B	max 20	220-240	4000	max 1600	15%	1,160	555523PLUSEMS



**Led Platax XL**

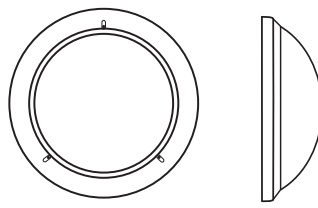

ø 380      100

**LED Platax XL**

	colour	W	V	Lm output	K	pcs	Kg	CELL
	B	22	220-240	2100	3000	006	1,350	555639.0101
	B	22	220-240	2100	4000	006	1,350	555618.0101
	<b>DALI 2</b> B	22	220-240	2100	3000	006	1,350	555639.0101DA
	<b>DALI 2</b> B	22	220-240	2100	4000	006	1,350	555618.0101DA
	N	22	220-240	2100	3000	006	1,350	555620.0101
	N	22	220-240	2100	4000	006	1,350	555619.0101
	G	22	220-240	2100	4000	006	1,350	555625.0101
	B	30	220-240	3000	3000	006	1,350	555639.0102
	B	30	220-240	3000	4000	006	1,350	555618.0102
	N	30	220-240	3000	3000	006	1,350	555620.0102
	G	30	220-240	3000	4000	006	1,350	555625.0102

**LED Platax XL EYE**

	colour	W	V	Lm output	K	pcs	Kg	CELL
•••	B	22	220-240	2100	3000	006	0,915	555641.0101
•••	B	22	220-240	2100	4000	006	0,915	555622.0101
•••	N	22	220-240	2100	3000	006	0,915	555623.0101
•••	G	22	220-240	2100	4000	006	0,915	555624.0101
•••	B	30	220-240	3000	3000	006	1,400	555641.0102
•••	B	30	220-240	3000	4000	006	1,400	555622.0102
•••	N	30	220-240	3000	3000	006	1,400	555623.0102
•••	G	30	220-240	3000	4000	006	1,400	555624.0102

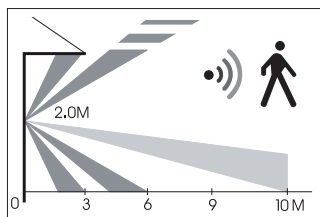

**LED Platax XL Emer Autotest**

**LED Platax XL EMER**

	colour	W	V	Lm output	K	pcs	Kg	CELL-E
	B	22	220-240	2100	3000	006	2,000	555639.EMER
	B	22	220-240	2100	4000	006	2,000	555618.EMER
	N	22	220-240	2100	3000	006	2,000	555620.EMER
	B	30	220-240	3000	3000	006	2,000	555639.EMER2
	B	30	220-240	3000	4000	006	2,000	555618.EMER2
	N	30	220-240	3000	3000	006	2,000	555620.EMER2
<b>DALI 2</b>	B	22	220-240	2100	3000	006	2,000	555639.DAEMER
<b>DALI 2</b>	B	22	220-240	2100	4000	006	2,000	555618.DAEMER

**LED Platax XL EMER + EYE**

	colour	W	V	Lm output	K	pcs	Kg	CELL-E
•••	B	22	220-240	2100	3000	006	2,000	555641.EMER
•••	B	22	220-240	2100	4000	006	2,000	555622.EMER
•••	N	22	220-240	2100	3000	006	2,000	555623.EMER
•••	B	30	220-240	3000	3000	006	2,000	555641.EMER2
•••	B	30	220-240	3000	4000	006	2,000	555622.EMER2
•••	N	30	220-240	3000	3000	006	2,000	555623.EMER2

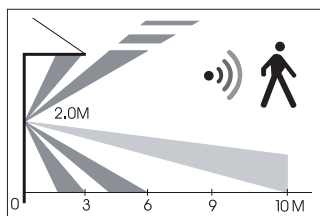

È possibile regolare la sensibilità di rilevamento, la distanza di intervento, la soglia di luminosità ed il tempo di accensione.  
*The detection sensitivity, intervention distance, luminosity threshold and lighting time can be adjusted.*





## Serie Platax Plus + Luna Piena

### Apparecchi in emergenza - *Emergency wired luminaires*

#### Apparecchi di illuminazione cablati in emergenza

Relco nella politica di offrire un servizio migliore alla clientela, ha deciso di utilizzare nei suoi apparecchi di illuminazione dotati di emergenza, solo INVERTER PER EMERGENZA CON AUTOTEST.

Le norme europee EN 1838, EN 60598-2-22, relative ai sistemi di illuminazione di emergenza, impongono che periodicamente, siano effettuati dei test per verificare sia il funzionamento sia l'efficienza (durata in emergenza) degli apparecchi di illuminazione che svolgono anche la funzione di illuminazione di emergenza. Questo costringe i manutentori dell'impianto ad interrompere la linea di alimentazione ed effettuare test con cadenza settimanale (test funzionale), e con cadenza trimestrale o annuale (test di autonomia).

Con i nostri kit di emergenza con autotest (conformi alla normativa europea EN 62034) queste prove vengono svolte automaticamente con cadenza programmabile in fase di installazione. Inoltre il nostro inverter analizza i tempi di normale accensione e spegnimento dell'apparecchio ed effettua (qualora possibile) i test nelle ore di assenza delle persone.

Eventuali anomalie sono segnalate tramite un indicatore (led) rosso verde.

A partire dal colore della segnalazione è possibile stabilire in maniera univoca gli eventuali problemi di funzionamento come evidenziato nella tabella seguente.

#### Emergency wired luminaires

Relco in its policy of offering a better service to customers, has decided to use only EMERGENCY INVERTER WITH SELF-TEST in its luminaires equipped with emergency.

The European standards EN 1838, EN 60598-2-22, relating to emergency lighting systems, require that tests be periodically carried out to verify both the functioning and the efficiency (duration in emergency) of the lighting fixtures which also the emergency lighting function. This forces the system maintainers to interrupt the power supply line and carry out tests on a weekly basis (functional test), and on a quarterly or annual basis (autonomy test).

With our emergency kits with self-test (complying with European standard EN 62034) these tests are carried out automatically with a programmable cadence during installation.

Furthermore, our inverter analyzes the normal switching on and off times of the appliance and carries out (where possible) the tests in the hours when people are absent.

Any anomalies are signaled by a red-green indicator (led). Starting from the color of the signal, it is possible to unequivocally establish any functioning problems as shown in the following table.

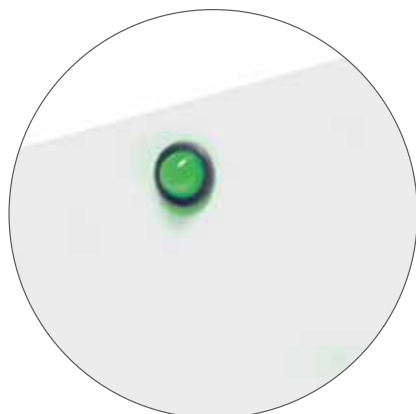

	Colore LED - LED indication	Stato - Status
	Verde fisso - Permanent Green	Batteria carica o in carica - Battery charge or charging
	Verde lampeggiante - Flashing Green	Funzione TEST avviata - TEST in progress
	Verde lampeggiante lento (1s ON - 1s OFF) Slow flashing green (1s ON - 1s OFF)	TEST di autonomia avviato Autonomy TEST in progress
	Rosso fisso - Permanent Red	Lampada guasta - Lamp failure
	Rosso lampeggio veloce (0,1s ON - 0,1s OFF) Fast flashing Red (0,1s ON - 0,1s OFF)	Guasto circuito di ricarica - Charging failure
	Lampeggio Rosso lento (1s ON - 1s OFF) Slow flashing Red (1s ON - 1s OFF)	Batteria guasta - Battery failure
	Verde e Rosso OFF - Green and Red OFF	Emergenza ON - Emergency ON

## Serie Platax Plus + Luna Piena

**Nuovo circuito LED studiato per garantire una perfetta omogeneità della diffusione luminosa del corpo lampada**  
*New LED circuit designed to ensure perfect homogeneity of the light diffusion of the lamp body*



**CRI 90**

Outdoor



# LED Luna piena

A richiesta On demand 1-10Vdc DALI 2

## LED Luna piena multipotenza

Plafoniera a LED stagna, idonea per applicazioni civili, commerciali, alberghiere.

**Corpo e cornice:** alluminio pressofuso laccato bianco, grigio e nero di serie, a richiesta versione oro, guarnizione in silicone, viti Torx anti-vandalo imperdibili.

**Verniciatura:** di tipo poliestere eseguita a polvere, resistente agli agenti atmosferici e alla corrosione e garantita per 1.000 ore in nebbia salina.

Colore Nero RAL 9005, bianco RAL9010 o grigio RAL 9007

**Diffusore:** in policarbonato opale, antiurto ed autoestinguente resistente agli UV.

**Cablaggio:** composto da alimentazione 220-240V 50Hz, cavi in PVC HT 105° non propagante la fiamma, doppio isolamento. LED Luna piena è installabile sia per impianto sotto parete che esterno.

## LED Luna piena multipotenza - Con sensore di movimento

Plafoniera a LED con sensore ad alta frequenza a 5,8 GHz. Colorazione neutra e gradevole, intensità e tonalità della luce invariate nel tempo. Sensore invisibile estremamente sensibile e silenzioso nell'accensione, con risposta immediata. È possibile regolare la sensibilità di rilevamento, la distanza di intervento, la soglia di luminosità ed il tempo di accensione.

## Caratteristiche tecniche LED Luna piena EMERGENZA SA

Plafoniera Stagna LED con Emergenza integrata.

Il Gruppo di Emergenza interviene automaticamente in caso di interruzione della rete elettrica.

- Flusso luminoso costante in emergenza.
- Spegnimento automatico per sottotensione di batteria.
- Batteria a 3 elementi 3,6 V, 4 A/h.
- Tempo di ricarica massimo 24 ore
- Autonomia 3h, con flusso al 15%.
- Spia LED di attivazione del circuito di ricarica.

**Conforme alla norma:** EN60598-1, RG0 nessun rischio fotobiologico ai fini della norma EN62471.

**Sorgente:** LED LUMILEDS 3528

**Led:** mantenimento del flusso luminoso minimo al 80%: 50.000h (L80B10).

**Driver multipotenza** : incluso.

**Grado IP:** IP65 certificato da laboratorio accreditato

## LED Luna piena multipower

Compact waterproof LED fitting suitable for civil, commercial, hotel applications, etc.

**Body and frame:** white, gray and black lacquered die-cast aluminum as standard, on request gold, silicone gasket, non-loosening Torx screws.

**Painting:** polyester powder type, resistant to atmospheric agents and corrosion and guaranteed for 1,000 hours in saline mist.

Color Black RAL 9005, white RAL9010 or grey RAL 9007

**Diffuser:** made by shockproof and self-extinguishing opal polycarbonate, UV resistant.

**Wiring:** includes 220-240V 50Hz control gear, non-flame propagating PVC HT 105° cables, double insulated. LED Luna piena can be installed in both concealed and outdoor circuits.

## LED Luna piena Eye - with motion sensor

Fitting with 5.8 GHz high-frequency sensor with neutral and pleasant colour, unaltered light intensity over time, extremely sensitive invisible sensor and silent switching-on, with instant response. The detection sensitivity, intervention distance, luminosity threshold and lighting time can be adjusted.

## LED Luna piena Emergency SA Technical features

Water Proof LED fitting with integrated Emergency Kit integrated.

Emergency Kit turns on when power is cut.

- Non stop light flow during emergency.
- Under voltage lockout.
- Battery with 3 elements 3,6V, 4 A/h included.
- Charging time max 24 hours.
- Autonomy 3h with flux 15%.
- LED Monitor to indicate mains-on conditions.

**According to standard:** EN60598-1, RG0 exempt from photo-biological risks in compliance with standard EN62471.

**Source:** LED LUMILEDS 3528

**Led:** maintenance of minimum luminous flux to 80%: 50.000h (L80B10).

**Driver multipower** : included.

**IP degre:** IP65 certified by an external laboratory

Outdoor



**A richiesta:** versione 2700K, 3000K e 6000K

**On demand:** 2700K, 3000K and 6000K versions

## Esempio di installazione in linea continua - Continuous line installation example

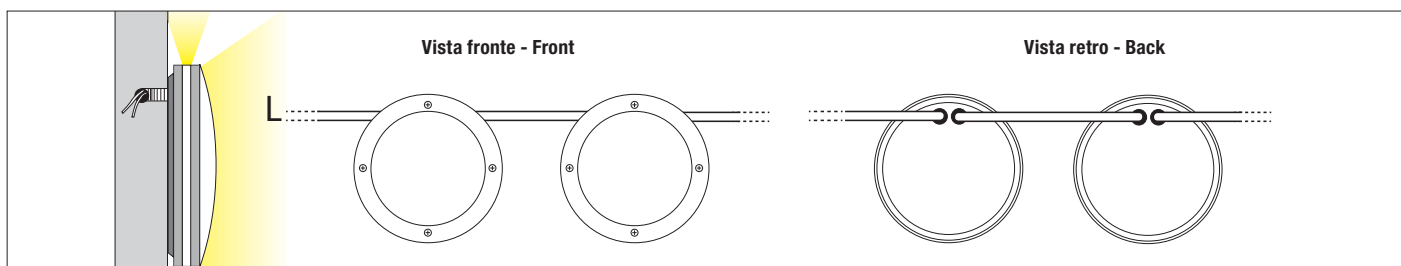

# LED Luna piena max 30W

220-240V 50/60Hz   850°  **IK10** **IP65**

## LED Luna piena multipower

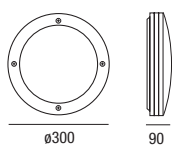

**CRI 90**

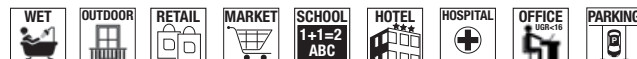

colour	W	V	Lm output	K	pcs	Kg	CELL
B	20	220-240	1800	4000	006	1,900	28922/BASIC
B	25	220-240	2300	4000	006	1,900	28922-25BASIC
B	30	220-240	2800	4000	006	1,900	28922-30BASIC
B	30	220-240	2800	4000	006	1,900	28922-30BASICE

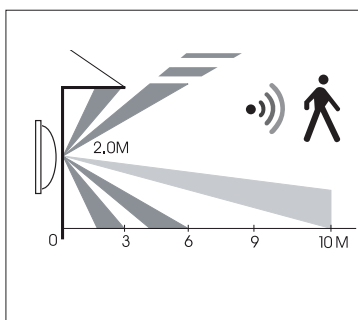

## LED Luna piena max 20W

colour	W	V	Lm output	K	pcs	Kg	CELL
N	max 20	220-240	1800	4000	006	1,900	28920
G	max 20	220-240	1800	4000	006	1,900	28921

## LED Luna piena max 20W EYE

colour	W	V	Lm output	K	pcs	Kg	CELL
B	max 20	220-240	1800	4000	006	1,900	28925
N	max 20	220-240	1800	4000	006	1,900	28923
G	max 20	220-240	1800	4000	006	1,900	28924

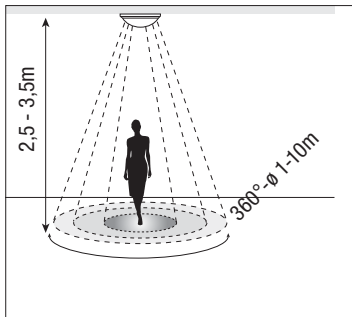

È possibile regolare la sensibilità di rilevamento, la distanza di intervento, la soglia di luminosità ed il tempo di accensione.

The detection sensitivity, intervention distance, luminosity threshold and lighting time can be adjusted.



Selezione Dip-Switch				Power	Lm Output	mA
Dip-Switch selection						
1	2	3	4	Watt	Lm	mA
•	ON	ON	•	10	950	450
ON	•	ON	•	15	1450	650
ON	ON	ON	•	20	1800	900

Impostazione standard di fabbrica  
Driver Standard factory setting



## LED Luna piena Emer Autotest



colour	W	V	K	Lm Output	Flux Lm	Kg	CELL-E
B 	20	220-240	4000	1800	15%	2,100	28928
N 	20	220-240	4000	1800	15%	2,100	28926
G 	20	220-240	4000	1800	15%	2,100	28927

## LED Luna Piena EMER EYE

colour	W	V	K	Lm Output	Flux Lm	Kg	CELL-E
B 	20	220-240	4000	1800	15%	2,100	28928/EYE

Outdoor

# BASIC series LED Kamaleon, IP65



## LED Kamaleon 6 lampade in una.

Plafoniera a LED stagna, idonea per applicazioni civili, commerciali, alberghiere, disponibile in 2 misure  $\varnothing 250\text{mm}$  e  $\varnothing 350\text{mm}$ , con possibilità di scelta tra tre diverse temperature di colore, bianco caldo, bianco neutro o bianco freddo e con scelta della potenza tra 12W, 15W, 18W per la misura più contenuta e 18W, 24W o 30W per la misura più grande.

Corpo e cornice: in nylon rinforzato con fibre di vetro, guarnizione in silicone, viti Torx anti-vandalo imperdibili.

Diffusore: in policarbonato opale, antiurto ed autoestinguento.

Cablaggio: composto da alimentazione 220-240V 50Hz, cavi in PVC HT 105° non propagante la fiamma, doppio isolamento. Installabile sia per impianto sotto parete che esterno; fornita di serie con pressacavo in nylon PG13,5.

## Kamaleon LED 6 lamps in one.

Watertight LED ceiling light, suitable for civil, commercial, hotel applications, available in 2 sizes  $\varnothing 250\text{mm}$  and  $\varnothing 350\text{mm}$ , with the possibility of choosing between three different color temperatures, warm white, neutral white or cold white and with a choice of power between 12W, 15W, 18W for the smallest size and 18W, 24W or 30W for the largest size.

Body and frame: in nylon reinforced with glass fibers, silicone gasket, captive vandal-proof Torx screws.

Diffuser: in opal polycarbonate, shockproof and self-extinguishing.

Wiring: composed of 220-240V 50Hz power supply, non-flame propagating 105 ° PVC cables, double insulation. Can be installed both for under-wall and external systems; supplied as standard with PG13.5 nylon cable gland.



**Cambia la cornice con un semplice click! scegli tra 3 colori diversi grigio, nero e bianco (da ordinare a parte).**  
**Change the frame with a simple click! choose between 3 different colors gray, black and white (on demand).**

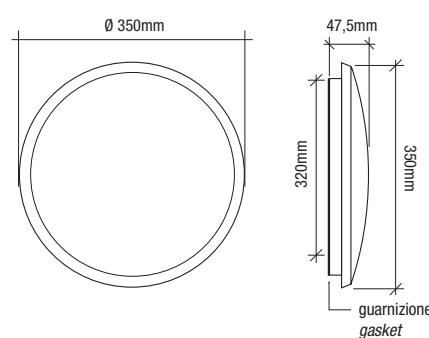
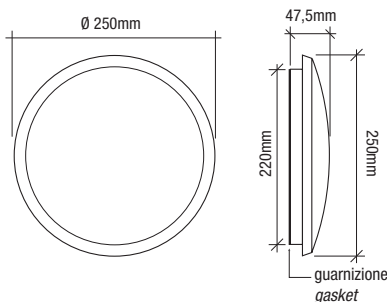

### LED Kamaleon $\varnothing 250\text{mm}$

Color	Code	W	K
□	2591	12/15/18	3000
			4000
			6000

Sorgente Source SMD LED

Flusso luminoso max. Lighting output max. 1200/1500/1800 Lm

Peso kg weight kg 0,75



220-240V 50/60Hz DRIVER INCLUDED

### LED Kamaleon $\varnothing 350\text{mm}$

Color	Code	W	K
□	2592	18/24/30	3000
			4000
			6000

Sorgente Source SMD LED

Flusso luminoso max. Lighting output max. 1800/2400/3000 Lm

Peso kg weight kg 0,85



220-240V 50/60Hz DRIVER INCLUDED

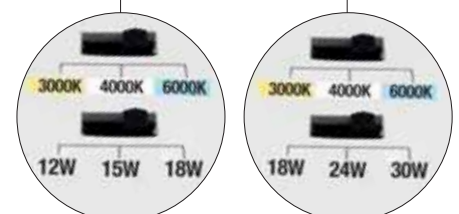





Outdoor

ACCESSORIO Cornice per Kamaleon NON INCLUSA  
Kamaleon Frame ACCESSORY NOT INCLUDED



+



Corpo lampada - Body lamp

Color



Code	Ø mm
2591	250
2592	350

Cornice - Frame

Color



Code	Ø mm
2591/W	250
2592/W	350

Cornice - Frame

Color



Code	Ø mm
2591/G	250
2592/G	350

Cornice - Frame

Color



Code	Ø mm
2591/B	250
2592/B	350

# LED Aster

Design: Ezio Didone

LED Aster è una lampada da parete/soffitto, molto versatile, pratica e poco ingombrante. Adatta ad illuminare spazi interni ed esterni, con grado IP65. L'illuminazione è uniforme e diffusa.

Particolarmente indicata per corridoi, bagni, balconi, ingressi ed aree provviste di sistemi antincendio ad umido (sprinkler's).

**Corpo:** alluminio pressofuso

**Diffusore:** in vetro temprato con finitura satinata.

**Guarnizione:** in silicone trasparente

**Verniciatura:** a polveri termoindurenti poliestere, resistente alla corrosione e agli agenti atmosferici.

**Sorgente:** LED 5630  SEOUL SEMICONDUCTOR

**Disponibile nei colori:** Bianco verniciato - Nero verniciato - Alluminio spazzolato

*Aster LED is a wall/ceiling lamp, very versatile, practical and compact. Suitable for indoor and outdoor lighting, with IP65 degree.*

*Lighting is uniform and diffused.*

*Particularly suitable for corridors, bathrooms, balconies, entrances and areas with sprinkler fire systems.*

**Body:** die cast aluminium

**Diffuser:** in tempered glass with satin finish.

**Gasket:** in transparent silicone

**Painting:** with polyester-powder thermohardening, against corrosion and atmospheric agents.

**Source:** LED 5630  SEOUL SEMICONDUCTOR

Available in the following colours: Painted white - Painted black - Aluminium Brushed



Outdoor

220-240V 50/60Hz     **IK07** **IP65**

## LED Aster



453

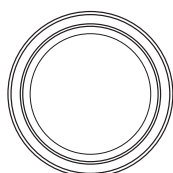

 | 87

colour	W	V	Lm	K	pcs	Kg	CELL
<b>B</b>	30	230	2000	4000	001	2,40	32351/LED
<b>N</b>	30	230	2000	4000	001	2,40	32353/LED
<b>S</b>	30	230	2000	4000	001	2,40	32355/LED



# Plafoniere per esterno con attacco E27

## Outdoor ceiling lights with E27 socket

Termoplastico + Vetro - *Thermoplastic + Glass*



Article	Code	Col.	(mm)	W	Source		
	<b>100S</b> <b>IP65</b> <b>IK08</b>		100S/TBIA	S	White	210x120x115	<b>E27</b> HALO - LED
			100S/TNER	S	Black		
	<b>130S</b> <b>IP65</b> <b>IK08</b>		130S/TBIA	S	White	275x155x115	<b>E27</b> HALO - LED
			130S/TNER	S	Black		
	<b>70S</b> <b>IP65</b> <b>IK08</b>		70SA/TBIA	S	White	210x120x100	<b>E27</b> HALO - LED
			70SA/TNER	S	Black	210x120x100	<b>E27</b> HALO - LED

Outdoor



# Termoplastico + Policarbonato - *Thermoplastic + Polycar-*



Taormina



Taormina Round - LED Taormina Round



70SG

Outdoor

Article		Code		Col.	(mm)	W	Source
	<b>Taormina</b> <b>IP65</b> <b>IK08</b>		T/E1031/B	S	White	100x190x95	<b>E27</b>
			T/E1031/N	S	Black		
			T/E1031/G	S	Grey		
	<b>Taormina Round</b> <b>IP65</b> <b>IK08</b>		T/E1033/B	S	White	∅ 191x105	<b>E27</b> HALO - LED
			T/E1033/N	S	Black		
			T/E1033/G	S	Grey		
	<b>70SG</b> <b>IP65</b> <b>IK08</b>		70SG/TBIA	S	White	120x210x110	<b>E27</b> HALO - LED
			70SG/TNER	S	Black		

# Termoplastico + Policarbonato - *Thermoplastic + Polycar-*



Article			Code		Col.	(mm)	Source
	Round grande IP65 IK08		T/E2060/B	S	White	Ø 280x128	E27
			T/E2060/N	S	Black		
	Tekno basic IP65 IK08		T/E1039/B	S	White	170x230x125	E27
	Tekno 2000 media IP65 IK08		T/E2150/B	S	White	130x205x112	E27
			T/E2150/N	S	Black		
	Tekno 2000 grande IP65 IK08		T/E2160/B	S	White	170x260x125	E27
			T/E2160/N	S	Black		

Outdoor

# Termoplastico + Policarbonato - *Thermoplastic + Polycarbonate*



150



Top con palpebra

Outdoor

Article		Code	Col.	(mm)	Source		
	<b>150</b> <b>IP65</b> <b>IK08</b>		150/TBIA	S	White	160x270x110	E27
			150/TNER	S	Black		
	<b>Top con palpebra</b> <b>IP65</b> <b>IK08</b>		T/E1046/B	S	White	Ø 215x130	E27
			T/E1046/N	S	Black		

## Dati tecnici per applicazione tramite canalina esterna - *Technical data for application via external conduit*

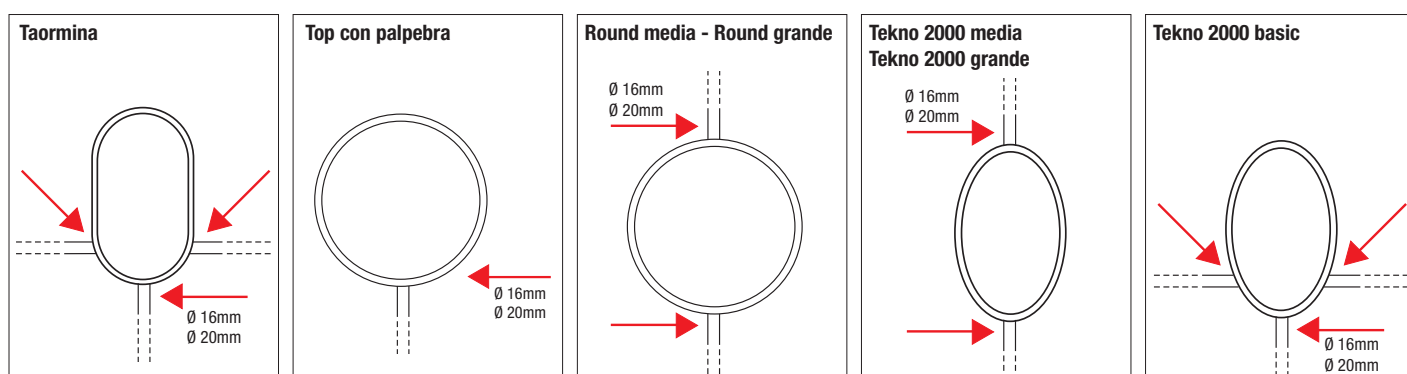



# Termoplastico + Policarbonato - Thermoplastic + Polycarbonate

## PLATAX E27

Plafoniera compatta stagna idonea per applicazioni civili, commerciali, alberghiere ed ovunque siano richieste caratteristiche di protezione contro l'ingresso di polveri o liquidi.

**Corpo e cornice:** in nylon rinforzato con fibre di vetro, guarnizione in silicone, vite-ria impermeabile.

**Riflettore:** in alluminio stampato.

**Diffusore:** in policarbonato opale antiurto ed autoestinguente.

**Cablaggio:** alimentazione 220/240V 50/60Hz, cavo non infiammabile HT105°, morsetteria in nylon.

Platax è installabile sia per impianto sotto parete che esterno; l'ingresso cavo è predisposto per un serracavo di diametro 16 mm. Confezione: termo-retraibile.

*Compact waterproof fitting suitable for public areas, halls, hotels, passages etc. where dust and water protection is necessary.*

*Casing and frame: nylon reinforced fibreglass, silicon gasket, non-loosening screws.*

*Reflector: Pressed aluminium. Diffuser: Self-extinguishing opal shockproof polycarbonate.*

*Wiring: 220/240V 50/60Hz power supply, HT105° non-flammable cable, nylon connector block.*

*The cable entry is predisposed for a 16 mm cable gland.*

*Packaging: thermoretractable film.*



220-240V 50/60Hz **IK09** **IP65**

### Platax E27

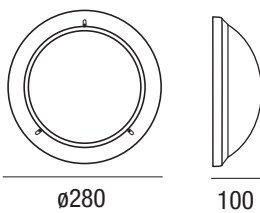

colour	Lampholder	V	pcs	Kg	S
<b>B</b>	E27	220-240	006	0,850	702198.0101
<b>N</b>	E27	220-240	006	0,850	702206.0101
<b>B</b>	2xE27	220-240	006	0,850	702199.0101

### Accessori - Accessories



**B** Cod. CO3001.100 - Ø 290mm - Visiera Nylon - Nylon visor  
**N** Cod. CO3002.100 - Ø 290mm - Visiera Nylon - Nylon visor

### Lampada non inclusa - Not included lamp



W	V			K		lm	Ra	DIM			H mm	Ø mm	Code
8~(60)	220-240	E27	360°	3000	A	800	80	SI	15.000	25.000	105	60	555286.0101
8~(60)	220-240	E27	360°	4000	A	800	80	NO	15.000	25.000	105	60	555286.4K
10~(100)	220-240	E27	360°	3000	A+	1000	80	SI	15.000	25.000	105	60	555383.0101
10~(100)	220-240	E27	360°	4000	A+	1000	80	NO	15.000	25.000	105	60	555383.4K

# LED Londra - LED Miami

**Installazione:** dotato di molle in acciaio per un rapido e facile inserimento (es. controsoffitti, pannelli in legno, piastrelle) oppure con cassaforma (accessorio), da murare.

**Corpo e ghiera:** alluminio cromato, o Bianco (RAL9010). Resistente alla corrosione e agli agenti atmosferici.

**Diffusore:** lente in vetro piano convessa a 60°; riflettore in alluminio anodizzato

**Guarnizione:** in gomma siliconica.

**Sorgente:** LED **SAMSUNG**. Mantenimento del flusso luminoso al 80%. 50.000h (L80B20)

**Alimentazione:** non inclusa; dotato di 50cm di cavo FROR PVC PVC 2x0,5mm<sup>2</sup>.

**Installation:** with steel springs for quick and easy insertion (e.g. in false ceilings, wooden panels and tiles) or with casing (accessory) for installation in walls.

**Housing and setting ring:** chromed aluminium or white (RAL9010).

**It is rustproof and resistant to atmospheric agents.**

**Shade:** flat-convex glass lens at 60°; reflector in anodized aluminium.

**Gasket:** in silicone rubber.

**Source:** LED **SAMSUNG**. Maintenance of 80% minimum luminous flux: 50,000h (L80B20).

**Power supply:** not included with a 50cm of FROR PVC PVC 2x0.5mm<sup>2</sup> wire.



LED Londra								
colour	Max W	mA	Optic	K	lm	pcs	Kg	S + L
B	1	Max 350	60°	3000	120	1	0,02	27343
B	1	Max 350	60°	4000	120	1	0,02	27343-4K
C	1	Max 350	60°	3000	120	1	0,02	27151
C	1	Max 350	60°	4000	120	1	0,02	27151-4K

LED Miami								
colour	Max W	mA	Optic	K	lm	pcs	Kg	S + L
B	1	Max 350	60°	3000	120	1	0,02	27345
B	1	Max 350	60°	4000	120	1	0,02	27345-4K
C	1	Max 350	60°	3000	120	1	0,02	27152
C	1	Max 350	60°	4000	120	1	0,02	27152-4K

**A richiesta:** disponibile nella versione 2700K e 6000K per ordine di almeno 100 pezzi - **On demand:** available in the 2700K and 6000K version on orders of at least 100 pieces of product

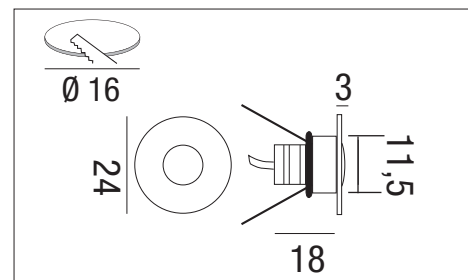
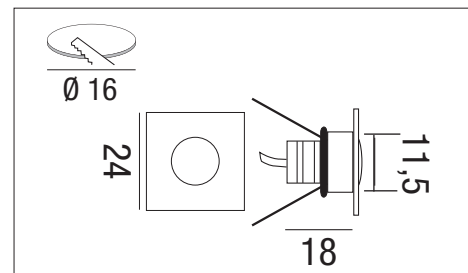

## Accessori NON inclusi - NOT included accessories

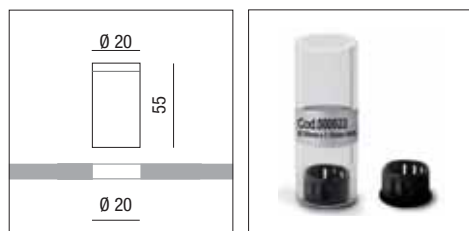

Cod. 000022  
Cassaforma Framework

LED Driver per singola installazione  
LED Driver for single installation  
Dim: 42x40x21mm

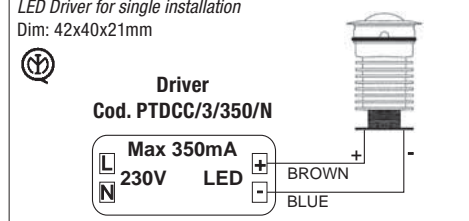

# LED Londra - LED Miami

Installazione in cartongesso con molle (includere)  
Plasterboard installation with springs (included)

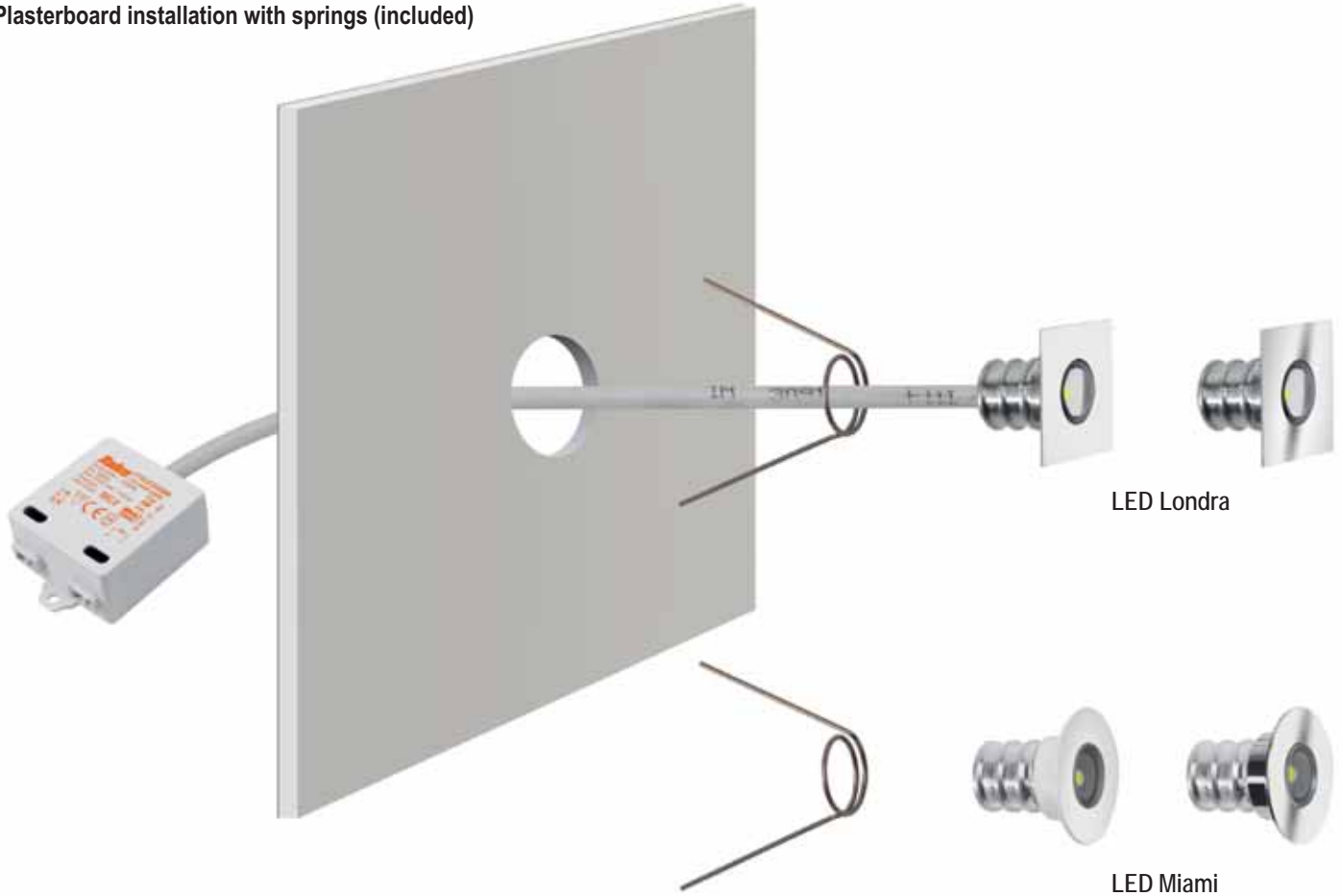

Installazione in piastrelle con cassaforma (NON inclusa)  
Tile installation with formwork (NOT included)

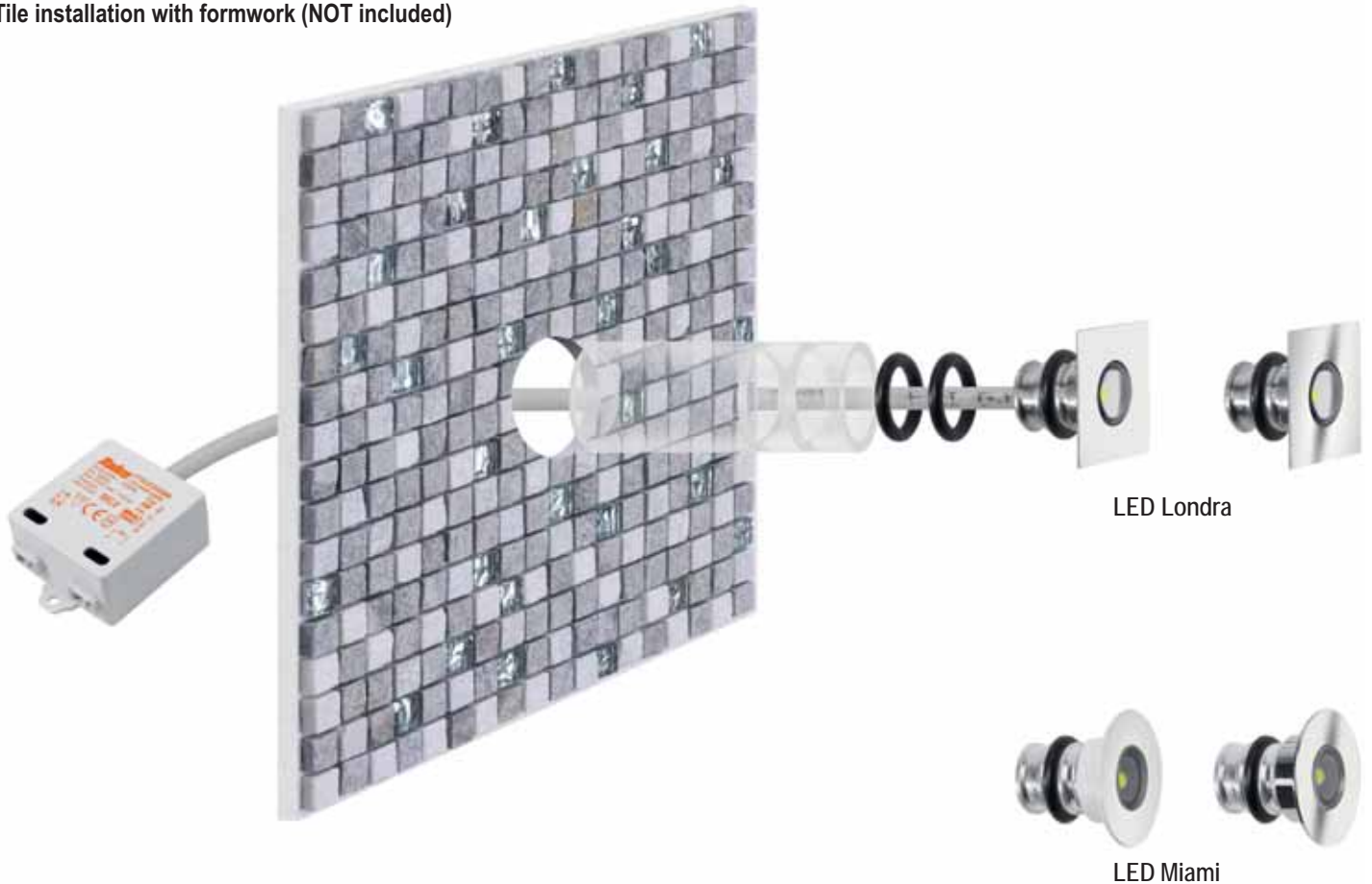

Recessed



# LED Parigi

Apparecchio a LED per utilizzo indoor e outdoor ad incasso, a pavimento/terreno, parete e soffitto. Prodotto non idoneo per l'installazione in piscine e fontane.  
Lo stesso prodotto, se dotato di un accessorio staffa, può essere utilizzato come proiettore architettonico.

**Installazione:** a pavimento con controcassa, a soffitto con alette di fissaggio

**Fascio ottico:** regolabile da 20° a 60° grazie ad un sistema di regolazione manuale retrostante o asimmetrico.

**Corpo e cornice:** in acciaio Inox AISI 304 senza viti a vista

**Diffusore:** in vetro trasparente temprato

**Guarnizione:** in gomma siliconica.

**Carrabilità:** resistenza al carico statico 2.000 Kg tramite controcassa ordinabile separatamente

**Alimentazione:** a bassa tensione di sicurezza in corrente costante (350mA). Da ordinare separatamente.

**Sorgente:** LED **SAMSUNG**

*LED fixture for indoor and outdoor recessed, floor / ground, wall and ceiling use. Product not suitable for installation in swimming pools and fountains.*

*The same product, if equipped with a bracket accessory, can be used as an architectural projector.*

*Installation: on the floor with outer casing, on the ceiling with fixing tabs*

*Optical beam: adjustable from 20° to 60° thanks to a manual adjustment system behind it or asymmetric.*

*Body and frame: in AISI 304 stainless steel without visible screws*

*Diffuser: in transparent tempered glass*

*Gasket: in silicone rubber.*

*Drive over: resists the static load 2,000 kg through the outer casing, which can be ordered separately*

*Power supply: low voltage safety constant current (350mA). To be ordered separately.*

*Source: LED **SAMSUNG***

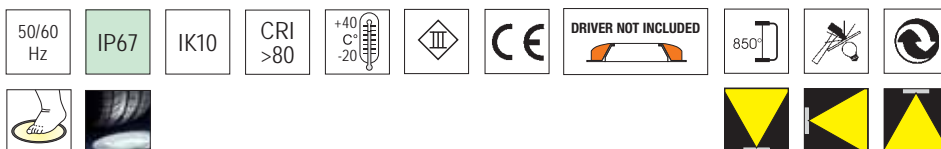

colour	Max W	Max mA	Optic	K	lm output	lm/W	pcs	Kg	S + L
B	2	Max 350	10/60°	3000	280	140	1	0,09	27184N
B	2	Max 350	10/60°	4000	280	140	1	0,09	27184/4KN
S	2	Max 350	10/60°	3000	280	140	1	0,09	27160N
S	2	Max 350	10/60°	4000	280	140	1	0,09	27160/4KN
S	2	Max 350	10/60°	6000	280	140	1	0,09	27188
S	1/2	350/700	60°	FULL COLOR	-	-	1	0,09	27176

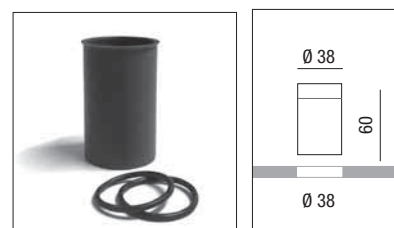
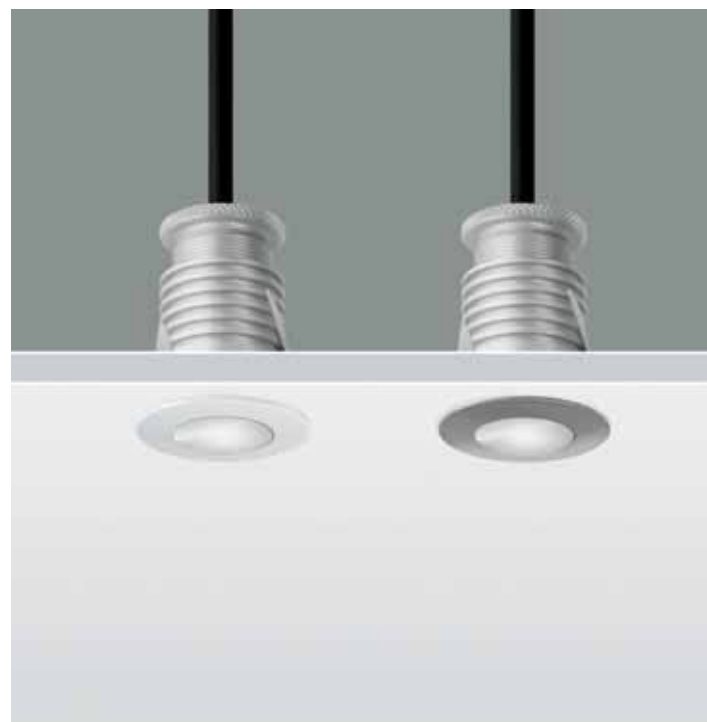
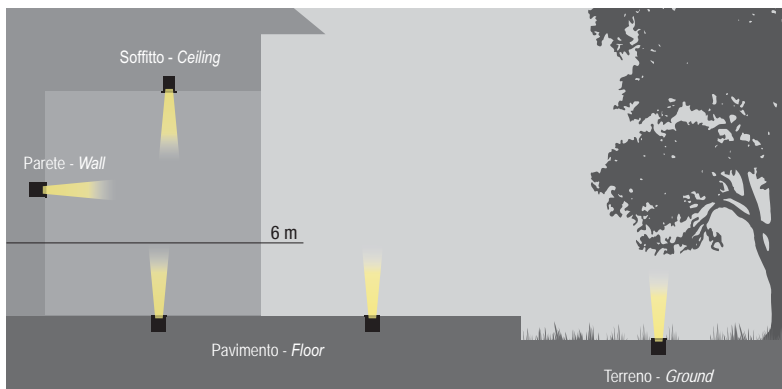
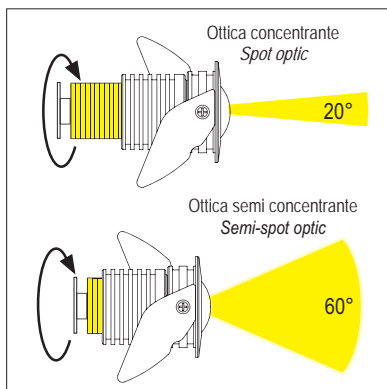
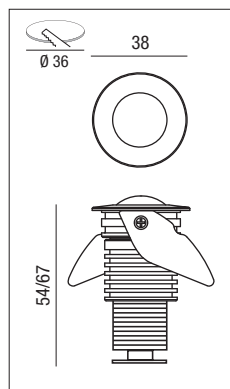

**Cod. 27243**  
Cassaforma per installazioni su muratura.  
Formwork for walling installations.

## LED Parigi, accessori NON inclusi - *NOT INCLUDED* accessory LED Parigi wall



**Cod. 27176 /KIT**  
**Staffa a parete**  
 Montaggio a parete orientabile  
**Wall bracket**  
 Adjustable wall mounting



**Cod. 24165**  
 Picchetto in alluminio  
 Aluminum picket



## LED Parigi ASY

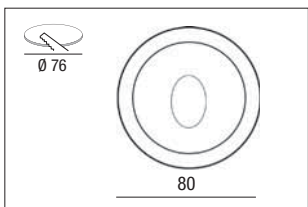
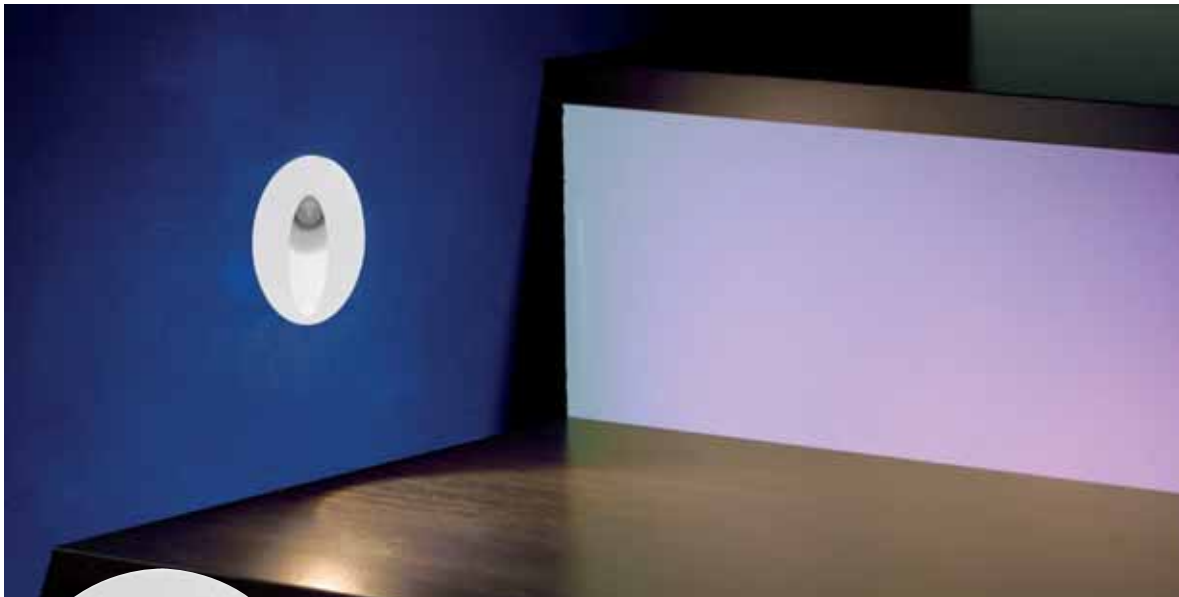

50/60 Hz	IP67	IK10	CRI >80	+40 C -20	III	CE	DRIVER NOT INCLUDED	850°	✂	↻
----------	------	------	---------	-----------------	-----	----	---------------------	------	---	---

colour	W	mA	Optic	K	lm output	lm/W	pcs	Kg	S + L
[B]	2	Max 350	ASY	3000	280	140	1	0,09	27184N/ASY
[B]	2	Max 350	ASY	4000	280	140	1	0,09	27184/4KN/ASY

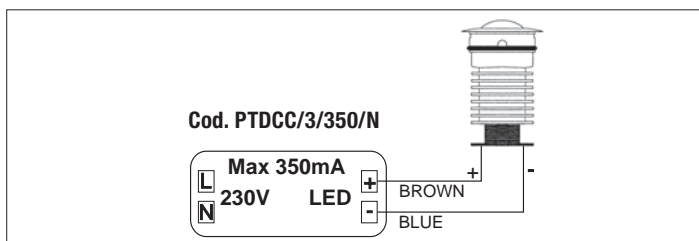

Recessed



2in1

LED Nasca apparecchio da incasso a pavimento/terra/parete adatto per illuminare percorsi pedonali, aree verdi, porticati ed edifici sia residenziali che pubblici.

**Corpo:** in alluminio pressofuso, struttura in acciaio inox 304.

**Diffusore:** vetro temprato alto 10 mm, garantisce il superamento del test standard IK10.

**Anello:** in gomma silicónica resistente alle alte temperature e impermeabile, alloggiamento di installazione in plastica PP resistente alla corrosione.

**Cassaforma:** in plastica PP resistente alla corrosione.

**Rischio fotobiologico:** nessun rischio fotobiologico, secondo EN 62471:2008.

**Viteria:** in acciaio inossidabile 304.

*LED Nasca floor/ground/wall recessed luminaire suitable for lighting pedestrian paths, green areas, porches and both residential and public buildings.*

*Body: in die-cast aluminum, structure in 304 stainless steel.*

*Diffuser: 10mm high tempered glass, ensure pass IK10 standard test.*

*Ring: high temperature resistant and waterproof silicone rubber, corrosion resistant PP plastic installation housing.*

*Formwork: Corrosion resistant PP plastic.*

*Photobiological risk: no photobiological risk, according to EN 62471:2008.*

*Screws: in 304 stainless steel.*

A richiesta - On demande

1-10Vdc

DALI 2

DYNA

Wireless

Vedi pag. VI - see page VI



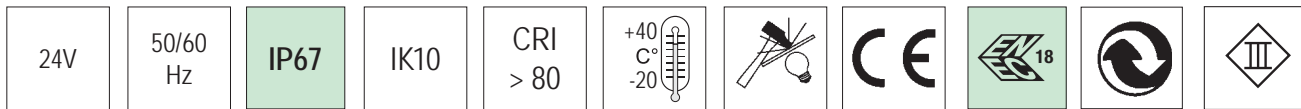

Driver NOT included



Ottica 30° - Optic 30°



Temperatura inferiore a 40°C - Temperature below 40 ° C



Resistenza al carico statico (5000 Kg) - Resistance to static load (5000 Kg)

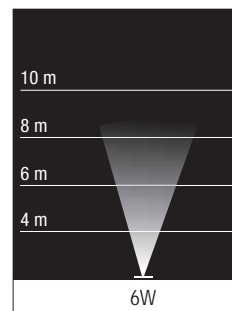

colour	W	angle	K	Max Lumen	Lm/W	pcs	Kg	S + L
S N	6	30°	3000	480	80	1	0,54	RM-03
S N	6	30°	3000	4000	480	80	0,54	RM-032CCT
S N	25	30°	3000	4000	2.000	80	0,65	RM-052CCT
S N	40	30°	3000	4000	3.200	80	0,75	RM-062CCT

2 CCT SWITCHABLE

2 CCT SWITCHABLE

2 CCT SWITCHABLE

Taratura standard 3000K, per modificare in 4000K seguire il foglio istruzioni  
Standard calibration 3000K, to change to 4000K follow the instruction sheet

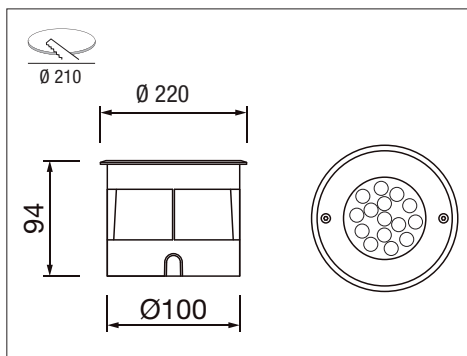
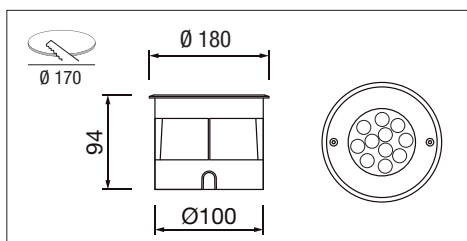
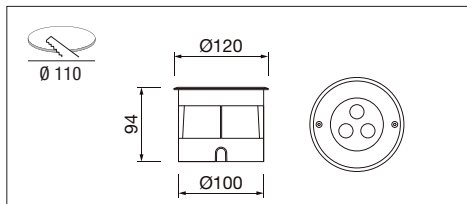

Installazione a terra  
Ground installation



Installazione a pavimento  
Floor installation



Installazione a parete  
Wall installation

Vetro temperato  
Hardened tempered glass

Telaio in acciaio inox 304  
304 stainless steel frame

Ottica più performante  
Higher performance optic

Custodia di installazione in plastica PP  
PP plastic installation housing



Recessed

Selezioniamo materiali della massima qualità possibile, per garantire una qualità del prodotto di alto livello. Vetro temperato ad alta resistenza con protezione fino a IK10, corpo di installazione in plastica PP, ottiche dal design speciale per mantenere i livelli di prestazioni dell'apparecchio più elevati.

We select materials of highest possible quality, to ensure high-degree product quality. High sturdy tempered glass with protection up to IK10, PP plastic installation housing, special design optics to keep the fixture higher performance levels.

LED Venezia, per l'illuminazione di luoghi come piazze, edifici, sculture e insegne.

- **Corpo e alloggiamento:** in acciaio inossidabile tipo 304.
- **Corpo:** in alluminio puro.
- **Vetro:** temperato trasparente da 15 mm, il carico statico dell'apparecchio può resistere a 5000 kg.
- **Modulo:** il modulo di illuminazione ha un sistema di inclinazione regolabile e ha un'ottica ad alte prestazioni.
- **Installazione:** a scatto.
- L'apparecchio di illuminazione può funzionare in modo continuo di lunghezze standard.
- Resistente all'acqua, è sicuro e affidabile per l'uso.
- La temperatura superficiale massima di tutte le temperature di contatto <50°C per sicurezza e affidabilità.
- Tutte le viti esterne sono realizzate in acciaio inossidabile 304.
- Le caratteristiche tecniche dell'apparecchio sono conformi alle norme EN 60598-1.

*LED Venezia, for landscape lighting places such as square, buildings, sculptures and signs.*

- **Body and housing:** stainless steel type 304 body and installation housing.
- **Body:** Pure aluminium construction fixture body.
- **Glass:** clear tempered glass 15 mm, the static load of the luminaire can resistance 5000kg.
- **Module:** the lighting module has tilt adjustable system, and it has high performance optics.
- **Installation:** snap in installation with no exposed hardware
- The luminaire can continuous run of standard lengths.
- Supplied with oil and water resistant, it is safety and reliable for using.
- The maximum surface temperature of all contact temperature <50°C for safety and reliable.
- All external screw are made of 304 stainless steel.
- The luminaire technical characteristics conform to EN 60598-1 standards.

A richiesta - On demand

1-10Vdc



DYNA

Wireless

Vedi Pag. VI - See page VI

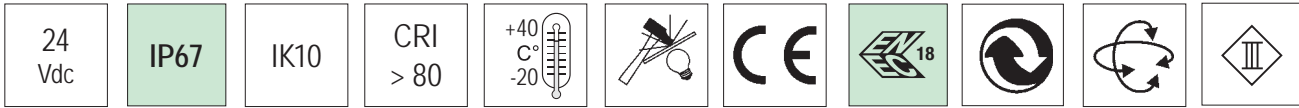

**Driver NOT included**

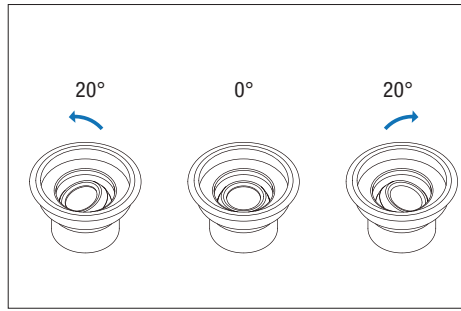
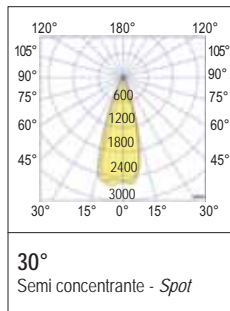

Il prodotto si applica con un design speciale, fornendo la soluzione di illuminazione più efficace per il comfort visivo, evitando abbagliamenti inutili e riducendo l'inquinamento luminoso, la direzione della luce regolabile.

*The product apply with special design, providing the most effective lighting solution for visual comfort, avoiding unnecessary glare and reducing light pollution, the light direction adjustable.*

colour	W	angle	K	Lumen	Lm/W	pcs	Kg	S + L
<b>S N</b>	10	30°	3000	800	80	1	1,80	RL21310-1

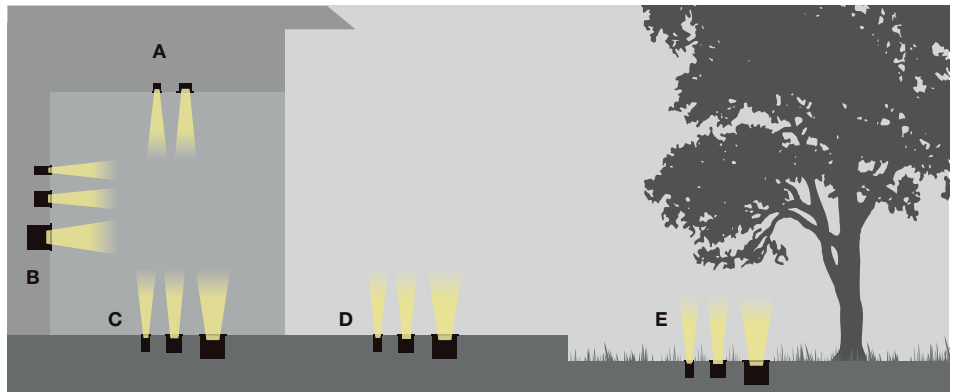
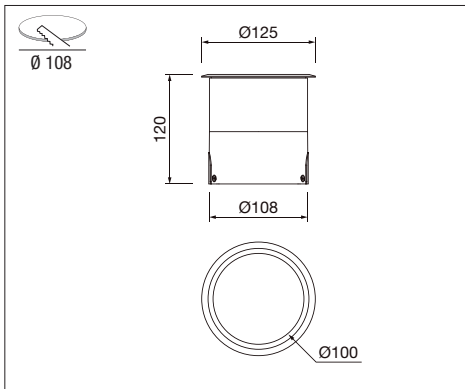

A Soffitto - Ceiling    B Parete - Wall    C Interno pavimento - Indoor floor    D Esterno pavimento - Outdoor floor  
E Terreno - Ground

Gli incassi a terra e a pavimento, hanno diversi gradi di resistenza alla torsione e al taglio, fino a 5000 Kg secondo EN 60598-2-13.

*Ground and floor level recessed luminaires, have different degrees of resistance to torsion and shear, up to 5000 Kg in accordance with EN 60598-2-13.*



Temperatura inferiore a 40°C  
*Temperature below 40 ° C*



Versione con ottica diffusore completo di vetro antiscivolo  
*Diffuser optics versions complete with non-slip glass*



Resistenza al carico statico (5000 Kg)  
*Resistance to static load (5000 Kg)*



Recessed



## LED Rondò - LED Naasby



Norme di riferimento  
Standard reference  
EN60598-1  
EN60598-2-1  
EN62471  
EN62031  
EN60598-2-5  
EN61547

LED Rondò e LED Naasby sono apparecchi da esterno, ad alto grado di protezione, utilizzabile sia tramite fissaggio che ad incasso ideale per giardini, parchi, aiuole, terrazzi, corselli per piscine.

**Installazione:** incassi a pavimento adatti per illuminare percorsi pedonali, aree verdi, porticati, edifici sia residenziali che pubblici.

**Cassaforma:** inclusa.

**Corpo:** in alluminio pressofuso. Verniciatura di tipo poliesteri eseguita a polvere resistente agli agenti atmosferici e alla nebbia salina. Ghiera e viterie in acciaio Inox AISI 316L.

**Schermo:** vetro temperato 4mm resistente agli shock termici e agli urti (LED Rondò), tecnopolimero (LED Naasby).

**Guarnizioni:** in gomma siliconica.

**Sorgente:** LED **SAMSUNG**

**Driver:** incluso (LED Rondò) escluso (LED Naasby).

*LED Rondò and LED Naasby are a luminaire for outdoor use, with high protection degree, for fixed or recessed installation, for gardens, parks, flowerbeds, terraces, Pool lanes.*

*Installation: floor recessed luminaires suitable for illuminating pedestrian paths, green areas, porches, buildings either public or domestic.*

*Recessed housing: included.*

*Housing: die-cast aluminium body. Polyester powder coating. Resistance to atmospheric agents and corrosion guaranteed in saline mist. Closing ring and screws in stainless steel AISI 316L.*

*Shield: 4mm tempered glass resistant against thermal shocks and collisions (LED Rondò), technopolymer (LED Naasby).*

*Gaskets: made with silicone rubber.*

*Source: LED **SAMSUNG***

*Driver: included (LED Rondò), not included (LED Naasby)*



Calpestabile e carrabile, fino a 10Km/h - 1000 Kg con pneumatici gonfiati ad aria. Non sostare.

*Walkable and suitable for vehicles, up to 10Km/h - 1000Kg with tyres inflated with compressed air.*

*Do not stand.*

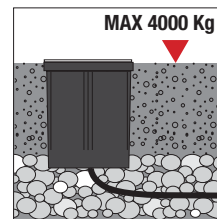

In caso di posa in muratura, la struttura muraria deve sostenere un carico di 4000 Kg. senza deformarsi. Il fondo della cassaforma è aperto, si rende necessario un fondo di ghiaia per il drenaggio.

*In the event of masonry laying, the wall structure must withstand a load of 4000 Kg. without deforming. The bottom of the framework is open, it's necessary a gravel bottom for drainage.*

# LED Rondò - LED Naasby



Recessed



# LED Rondò

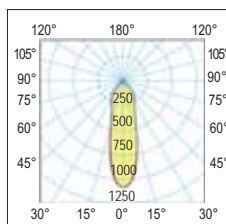

25°  
Semi concentrante - Spot

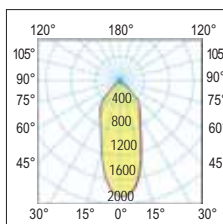

A richiesta - On demand  
40°  
Intermedio - Medium

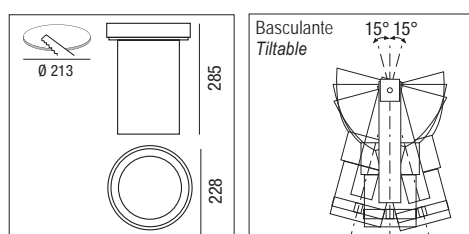
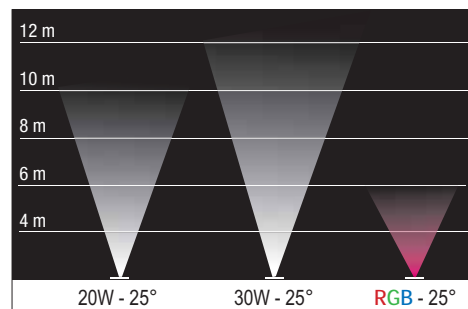

220-240 Vac	110 Vac a richiesta on demand	50/60 Hz	IP67	IK10	CRI >80	+40°C -20°C	CE	DRIVER INCLUDED RIPPLE FREE
850°	RG0	LOW FLICKER						

colour	Max W	angle	K	nominal lm tc = 25°C	lm output	lm/W	pcs	Kg	CELL
C	20	25°	4000	2.600	2.300	116	1	3,8	32567
C	20	25°	3000	2.600	2.300	116	1	3,8	32567-3K
C	30	25°	4000	3.900	3.480	116	1	3,8	32541
C	30	25°	3000	3.900	3.480	116	1	3,8	32540

A richiesta: per quantità disponibile con apertura di fascio a 40° - On demand: for quantity, available with 40° beam angle  
A richiesta: per quantità minima 100 pezzi disponibili a 2700K - On demand: for quantity min 100 pcs available 2700K

Recessed





# LED Naasby R

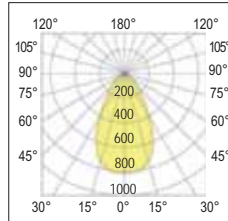

360°  
Diffondente - Diffusing

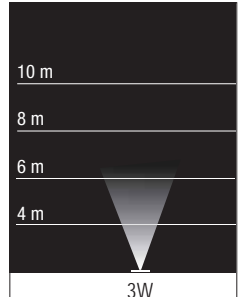
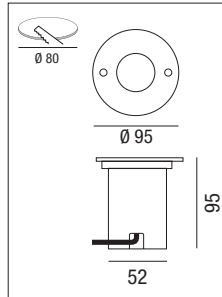

50/60 Hz IP67 IK09 CRI >80 +40°C / -20°C III CE DRIVER NOT INCLUDED 850°

colour	Max W	mA	angle*	K	nominal lm - tc = 25°C	lm output	lm/W	pcs	Kg	S+L
C	3	350	360°	4000	426	370	125	1	0,55	90.039/4K
C	3	350	360°	3000	426	370	125	1	0,55	90.039

\* Fascio luminoso a luce diffusa - Diffused light beam

# LED Naasby Q

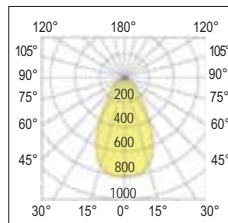

360°  
Diffondente - Diffusing

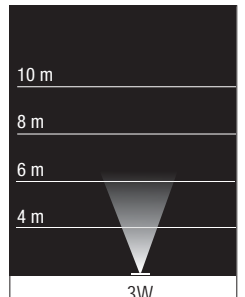
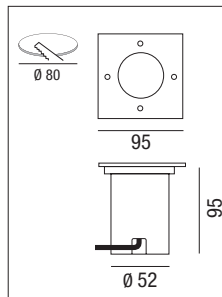

50/60 Hz IP67 IK09 CRI >80 +40°C / -20°C III CE DRIVER NOT INCLUDED 850°

colour	Max W	mA	angle*	K	nominal lm - tc = 25°C	lm output	lm/W	pcs	Kg	S+L
C	3	350	360°	4000	426	370	125	1	0,55	90.034/4K
C	3	350	360°	3000	426	370	125	1	0,55	90.034

\* Fascio luminoso a luce diffusa - Diffused light beam

## Esempi applicativi - application examples

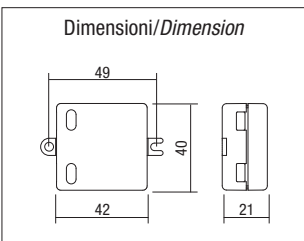
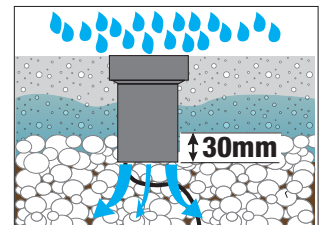
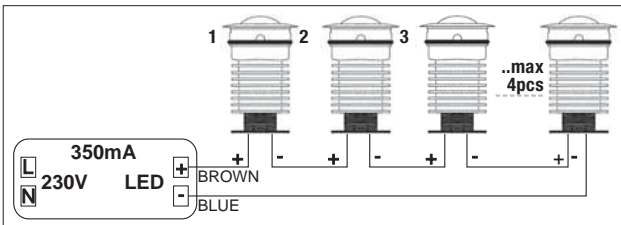
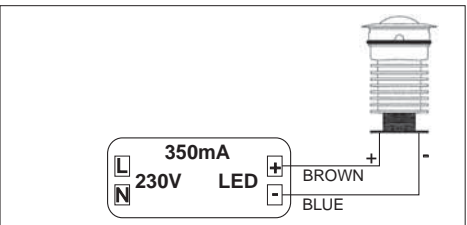

**Cod. PTDC3/350/N**  
3W  
LED Driver per singola installazione  
LED Driver for single installation

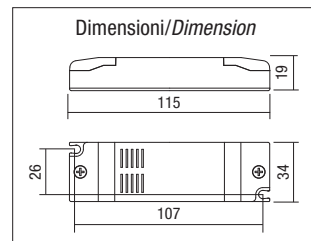

**Cod. RN9150-2**  
Max 15W  
LED Driver per collegamento in serie  
LED Drivers for series connection

Al fine di permettere un adeguato drenaggio si consiglia di preparare un fondo di ghiaia in fase di installazione. Per il collegamento è necessario l'utilizzo di nastro agglomerante, tipo PE.  
We advise you to prepare a gravel drain fund for installing the products, to ensure suitable drainage. The PE type agglomerating tape is required for the connection.

Recessed

LED Firenze, per l'illuminazione di luoghi come piazze, edifici, sculture e insegne.

- **Corpo:** in acciaio inossidabile tipo 304, custodia di installazione in ABS / acciaio inossidabile tipo 304.
- **Vetro:** temperato trasparente da 15 mm. Il carico statico dell'apparecchio può resistere a 5000 kg.
- **Ottica:** buon design, speciale per ottica ad alte prestazioni, e sistema antiriflesso.
- **Installazione:** a scatto senza.
- Resistente all'acqua, è sicuro e affidabile per l'uso.
- La temperatura superficiale massima di tutte le temperature di contatto <50°C per sicurezza e affidabilità.
- Tutte le viti esterne sono realizzate in acciaio inossidabile 304.

*LED Firenze, for landscape lighting places such as square, buildings, sculptures and signs.*

- **Body:** stainless steel type 304 body, ABS stainless steel type 304 installation housing.
- **Glass:** clear tempered glass 15 mm, the static load of the luminaire can resistance 5000kg.
- **Optic:** special good design for high performance optics and anti glare system.
- **Installation:** snap in installation with no exposed hardware
- Supplied with oil and water resistant, it is safety and reliable for using.
- The maximum surface temperature of all contact temperature <50°C for safety and reliable.
- All external screw are made of 304 stainless steel.
- The luminaire technical characteristics conform to EN 60598-1 standards.

A richiesta - On demand

1-10Vdc

DALI 2

DYNA

Wireless

Vedi Pag. VI - See page VI

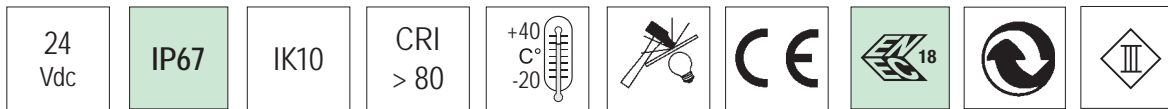

**Driver NOT included**

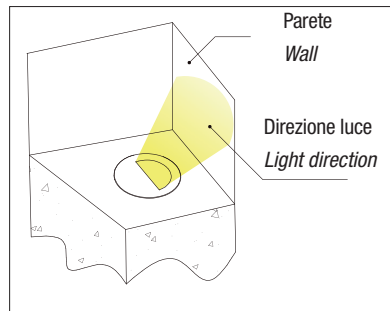
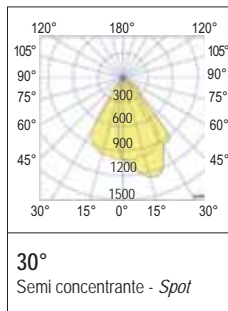

Il prodotto si applica con un design speciale, fornendo la soluzione di illuminazione più efficace per il comfort visivo, evitando abbagliamenti inutili e riducendo l'inquinamento luminoso.

*The product apply with special design, providing the most effective lighting solution for visual comfort, avoiding unnecessary glare and reducing light pollution.*

colour	W	angle	K	Lumen	Lm/W	pcs	Kg	S + L
<b>S N</b>	6	30	3000	500	83	1	1,50	RL2146-2

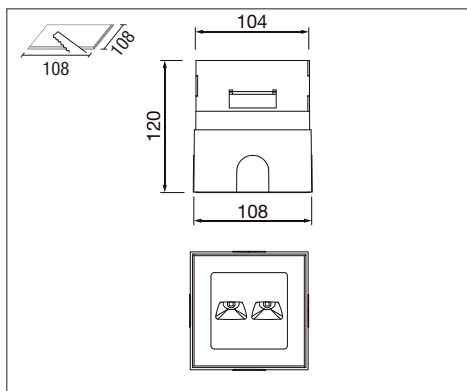

Selezioniamo materiali della massima qualità possibile, per garantire una qualità del prodotto di alto livello. Vetro temperato ad alta robustezza con protezione fino a IK10, corpo di installazione in acciaio inox 304, riflettore dal design speciale per mantenere l'apparecchio a livelli prestazionali più elevati.

*We select materials of highest possible quality, to ensure high-degree product quality. High sturdy tempered glass with protection up to IK10, 304 stainless steel installation housing, special design reflector to keep the fixture higher performance levels.*

Gli incassi a terra ea terra, hanno diversi gradi di resistenza alla torsione e al taglio, fino a 5000 Kg secondo EN 60598-2-13.

*Ground and floor level recessed luminaires, have different degrees of resistance to torsion and shear, up to 5000 Kg in accordance with EN 60598-2-13.*



Temperatura inferiore a 40°C  
Temperature below 40 ° C



Versione con ottica diffusore completo di vetro antiscivolo  
Diffuser optics versions complete with non-slip glass



Resistenza al carico statico (5000 Kg)  
Resistance to static load (5000 Kg)



Installato a filo pavimento  
Installed flush with floor



Recessed



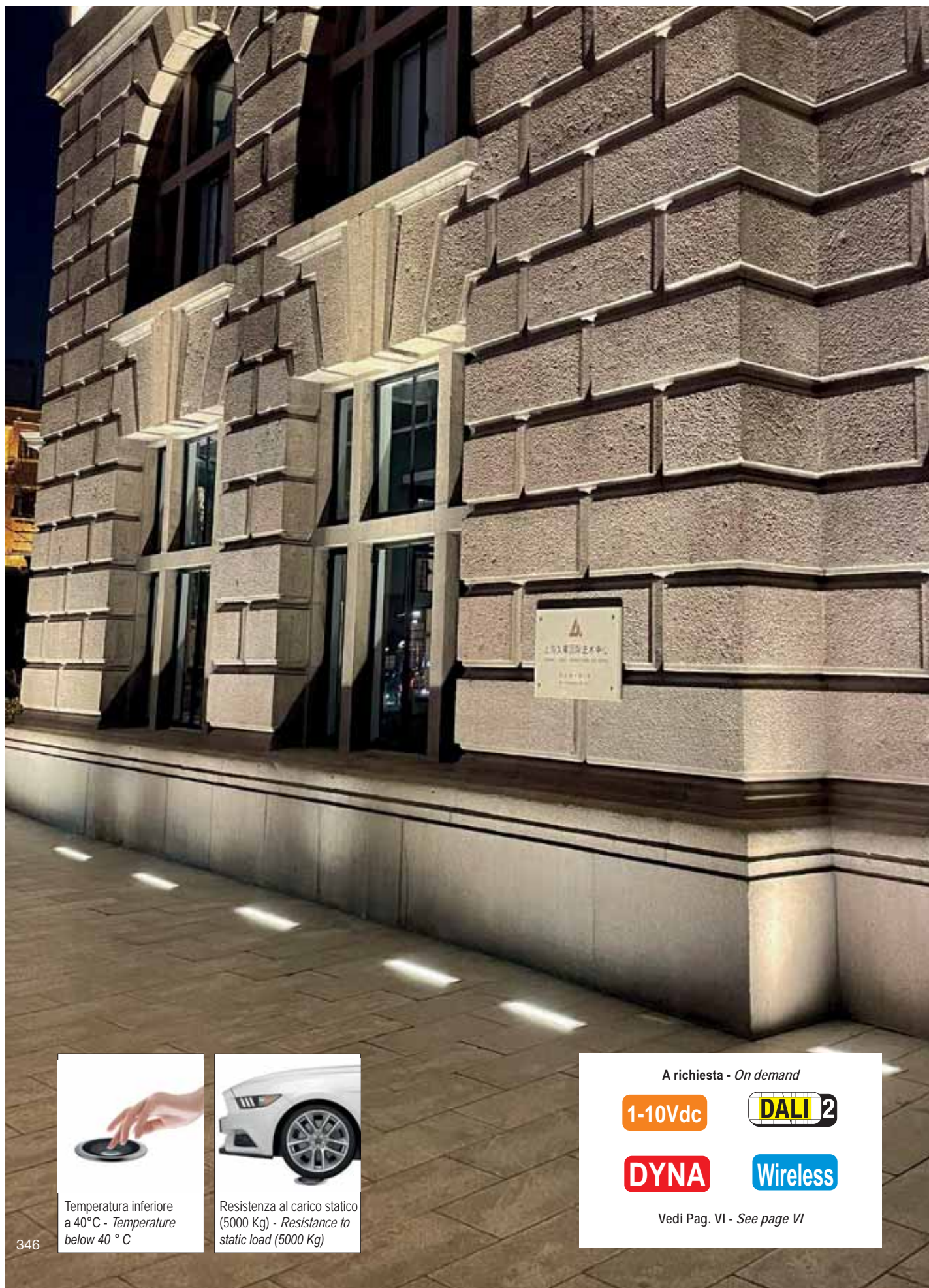

Temperatura inferiore a 40°C - *Temperature below 40 °C*



Resistenza al carico statico (5000 Kg) - *Resistance to static load (5000 Kg)*

A richiesta - *On demand*

1-10Vdc



DYNA

Wireless

Vedi Pag. VI - *See page VI*

# LED Monocilindrico

Apparecchio a LED da incasso per aree urbane e residenziali. Adatto per illuminare edifici, monumenti e strade.

**Installazione:** a pavimento con cassaforma

**Corpo e cornice:** estruso in alluminio anodizzato minimo 20 micron

**Cornice esterna:** cornice esterna 316 L cromo satinato

**Diffusore:** in vetro trasparente temprato

**Guarnizione:** in gomma siliconica.

**Carrabilità:** calpestabile e carrabile, fino a 10Km/h - 1000 Kg con pneumatici gonfiati ad aria. Non sostare.

**Alimentazione:** Da ordinare separatamente.

Copertura laterale iniezione in alluminio

*Recessed LED luminaire for urban and residential areas. Suitable for illuminating buildings, monuments and streets.*

*Installation: on the floor with formwork*

*Body and frame: extruded anodized aluminum at least 20 micron*

*External frame: external frame 316 L satin chrome*

*Diffuser: in tempered transparent glass*

*Gasket: silicone rubber.*

*Drive-over: walkable and drive-over, up to 10Km / h - 1000kg with air-inflated tires. Don't stop.*

*Power supply: To be ordered separately.*

*Aluminum injection side cover*

24  
Vdc

IP67

IK10

CRI  
> 85

+45  
C°  
-30

**Driver NOT included**



colour	W	angle	K	nominal Im tc = 25°C	Im output	lm/W	pcs	Kg	S + L
C	24	25°	4000	2.600	2.225	92	1	4,00	RL218NWM01
C	24	25°	3000	2.600	2.225	92	1	4,00	RL218WWM01
C	48	25°	4000	5.000	4.320	90	1	7,30	RL436NWM01
C	48	25°	3000	5.000	4.320	90	1	7,30	RL436WWM01

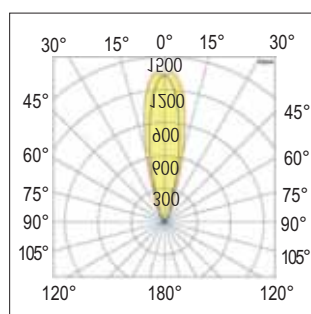
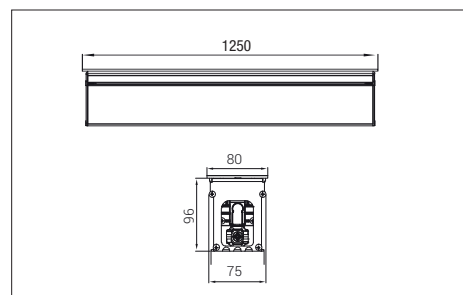
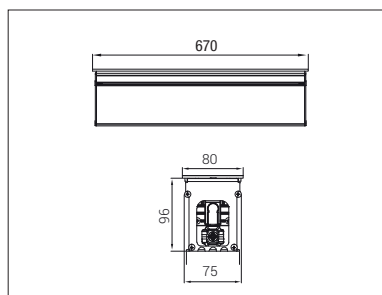

H (mt)	Ø (m)	E <sub>max</sub> (lx)
3.0	3,59	102
1.5	2,99	147
2.0	2,39	230
1.5	1,8	408
1.0	1,20	919
0.5	0,60	3674

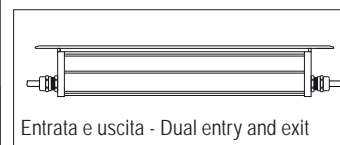
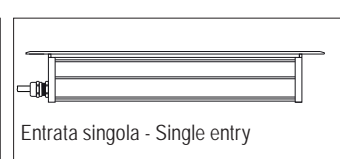
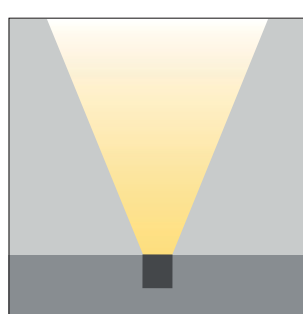

## A richiesta - On demand

**Angolo extra stretto**  
Extra narrow angle

**Angolo ampio**  
Wide angle

**Senza lente**  
Without lens

**Asimmetrico**  
Asymmetrical

**Ellittico stretto**  
Elliptical narrow

**Ellittico medio**  
Elliptical medium

Recessed



Apparecchio da incasso a pavimento/terra/parete previsto per le applicazioni secondo necessità. Luce laterale radiale ad emissione unilaterale e bi-direzionale, con elevato comfort visivo e buon effetto antiriflesso.

**Corpo:** in alluminio pressofuso. Nero RAL 9005

**Diffusore** in pc di alta qualità.

**Anello:** in gomma siliconica resistente alle alte temperature e impermeabile

**Cassaforma:** in plastica PP resistente alla corrosione.

**Rischio fotobiologico:** nessun rischio fotobiologico, secondo EN 62471:2008.

**Viteria:** in acciaio inossidabile 304.

*Floor/ground/wall-mounted recessed luminaire intended applications as required.*

*Side radial light with unilateral & bidirectional emission, it with high visual comfort and good anti glare effect.*

**Body:** die-casting aluminium body. RAL 9005 Black

**Diffuser:** high quality pc diffuser.

**Rubber ring:** high temperature resistant and waterproof silicone rubber ring

**Housing:** corrosion resistant PP plastic installation housing.

**Photo-biological risk:** no photo-biological risk, in accordance with EN 62471:2008.

**Screws:** all external screw are made of 304 stainless steel.

A richiesta - On demand

1-10Vdc

DALI 2

DYNA

Wireless

Vedi Pag. VI - See page VI



24 Vdc	IP67	IK09	CRI > 80	+40°C -20°C		CE	EN 18		
--------	------	------	----------	----------------	--	----	-------	--	--

**Driver NOT included**



 Doppia luce  
Double light

 Singola luce  
Single light

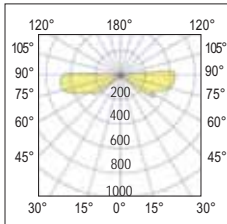

120°  
Semi concentrante - Spot



Temperatura inferiore a 40°C - Temperature below 40 ° C



Resistenza al carico statico (5000 Kg) - Resistance to static load (5000 Kg)

colour	W	angle	K	Lumen	Lm/W	pcs	Kg	S+L
<b>S N</b>	2	120°	3000	140	70	1	0,54	RLM-01A

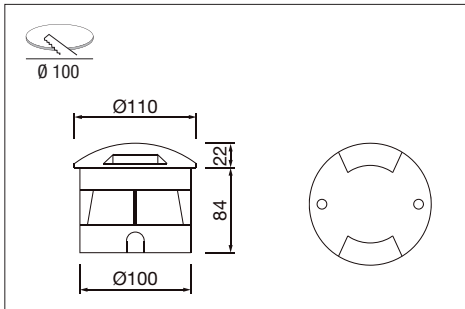

Installazione a terra  
Ground installation



Installazione a pavimento  
Floor installation



Installazione a parete  
Wall installation

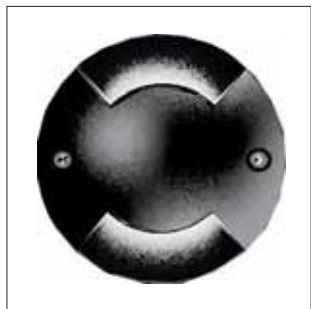

LED Radiante viene fornito con frangiluce doppia emissione  
LED Radiante comes with double emission light diffuser

**Accessori NON inclusi**  
NOT included accessories



**Cod. M-01B**  
Frangiluce mono emissione  
Mono emission light diffuser

Recessed

Apparecchio da incasso a pavimento/terra/parete previsto per le applicazioni secondo necessità. Luce laterale radiale ad emissione bidirezionale, con elevato comfort visivo e buon effetto antiriflesso.

**Corpo:** in alluminio pressofuso. Nero RAL 9005

**Diffusore:** in pc di alta qualità.

**Anello:** in gomma siliconica resistente alle alte temperature e impermeabile

**Cassaforma:** in acciaio zincato a caldo.

**Rischio fotobiologico:** nessun rischio fotobiologico, secondo EN 62471:2008.

**Viteria:** in acciaio inossidabile 304.

*Floor/ground/wall-mounted recessed luminaire intended applications as required. Side radial light with unilateral & bidirectional emission, it with high visual comfort and good anti glare effect.*

**Body:** die-casting aluminium body. RAL 9005 Black

**Diffuser:** high quality pc diffuser.

**Rubber ring:** high temperature resistant and waterproof silicone rubber ring

**Housing:** in hot galvanized steel.

**Photo-biological risk:** no photo-biological risk, in accordance with EN 62471:2008.

**Screws:** all external screw are made of 304 stainless steel.

A richiesta - On demand

1-10Vdc

DALI 2

DYNA

Wireless

Vedi Pag. VI - See page VI



24 Vdc	IP67	IK09	CRI > 80	+40°C -20°C		CE	EN 18		
--------	------	------	----------	----------------	--	----	-------	--	--

Driver NOT included

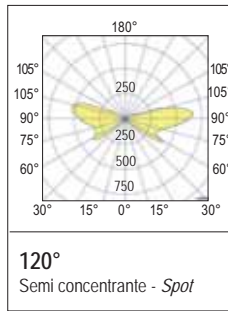

Temperatura inferiore a 40°C - Temperature below 40 ° C



Resistenza al carico statico (5000 Kg) - Resistance to static load (5000 Kg)



colour	W	angle	K	Lumen	Lm/W	pcs	Kg	S+L
S	4	120°	3000	280	70	1	0,83	RLM-16A

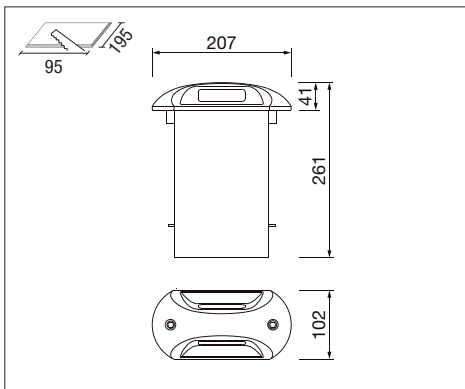

Installazione a terra  
Ground installation



Installazione a pavimento  
Floor installation



Installazione a parete  
Wall installation



Recessed



# illuminazione RGB - RGB lighting



RGB

Creare suggestive scenografie luminose in grado di valorizzare architetture importanti, ma anche di dare un valore estetico impensabile ad edifici anonimi. A queste possibilità offerte dalle luci colorate oggi si può aggiungere un elemento in più, ovvero quello del dinamismo. Il cambio di colore e di intensità della luce reso possibile dagli apparecchi di illuminazione RGB o RGBW diventa un vero e proprio cambio di scenari spettacolari.

Questo tipo di soluzione si applica ai seguenti prodotti

*Creating suggestive luminous scenographies able to enhance important architectures, but also to give an unthinkable aesthetic value to anonymous buildings. To these possibilities offered by colored lights today we can add an extra element, namely that of dynamism. The change of color and intensity of light made possible by RGB or RGBW lighting fixtures becomes a veritable cambio of spectacular scenarios.*

*This type of solution applies to the following products*

LED Lince 68 Wall Washer RGBW

IP68



LED Lince 68 RGBW

IP68

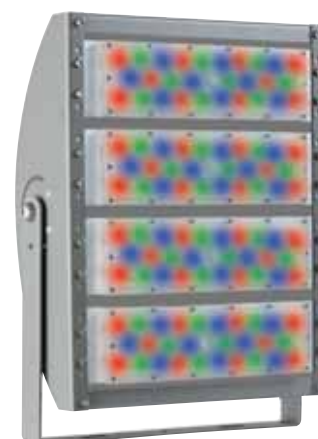

LED Lampo RGBW

LED Monza Round Wall Washer RGBW



LED Rondò RGB

LED Flex RGB



LED Gargano RGB





# LED Monza round Wall Washer RGBW



Sistema LED lineare per applicazioni professionali nell'illuminazione di facciate, portici, sottopassaggi e in generale per l'illuminazione di particolari elementi architettonici. A richiesta è possibile collegare gli apparecchi in serie per ottenere delle linee di luce continua.

**Installazione:** su superfici verticali e orizzontali (completo di staffa di fissaggio).

**Corpo:** in policarbonato trasparente, resistente agli urti.

**Testate di chiusura:** in PVC, colore nero

**Staffa di fissaggio:** in alluminio, verniciata con polvere termoidurente poliesteri

**Guarnizione:** in gomma ai siliconi dalle rilevanti prestazioni meccaniche ed elastiche

**Dispositivo anticondensa:** valvola di compensazione e riciclo dell'aria

**Norme di riferimento**

EN60598-1; EN60598-2-1; EN62471; EN62031; EN61547

**Sorgente:** LED RGBW

**Colori della luce ottenibili:** tutta la banda cromatica delle radiazioni visibili compreso il BIANCO

**Cablaggio:** 1,5m cavo tipo H05RN-F 5x1mm<sup>2</sup> e connettore rapido 5 poli IP66 maschio/femmina per la connessione elettrica

*LED linear system for professional lighting applications on facades, arcades, tunnels and generally to light up particular architectural elements. On demand it is possible to make a serial connection of the luminaires to have continuous light lines.*

**Installation:** on vertical and horizontal surfaces (complete with fixing bracket)

**Housing:** made by transparent polycarbonate, resistant to collisions

**End caps:** made by PVC, black color

**Fixing bracket:** made by aluminum, coated with polyester thermoset powder

**Gasket:** made by silicone rubber with high mechanical and elastic performance

**Anti-condensate device:** valve for compensation and circulation of air

**Standard reference**

EN60598-1; EN60598-2-1; EN62471; EN62031; EN61547

**Light source:** RGBW LEDs

**Achievable light colors:** all the chromatic range of visible radiations WHITE included

**Wiring:** 1,5m cable type H05RN-F 5x1mm<sup>2</sup> and 5-pole IP66 male/female quick connector for the electrical connection

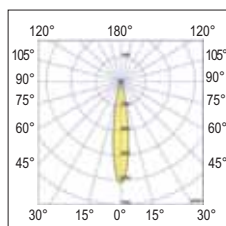

15°  
Concentrate  
Narrow  
Standard transparent shield

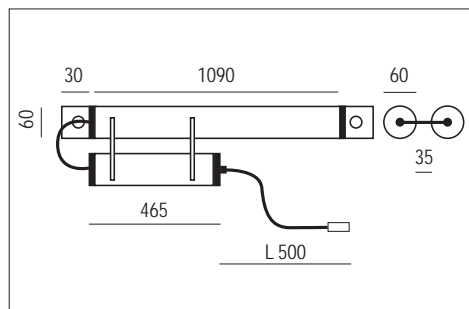
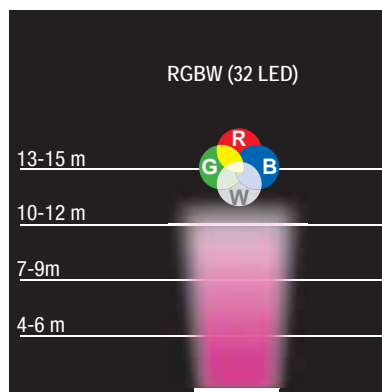

220-240 Vac	50/60 Hz	IP67	IK09	+40 C° -20	850°		
		CE	Driver included				

colour	W	angle	nominal lm tc = 25°C	lm output	pcs	Kg	CELL
T	40	15°	2640	R = 360 - G = 650 - B = 240 W = 740 (6500K)	1	1,20	27393/RGB

Predisposto per cablaggio passante (vedi accessorio opzionale cod. XPG9-P104)  
Set-up for through-wiring (see optional accessory code XPG9-P104).



# LED Monza round Wall Washer RGBW

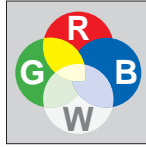

Questa tecnologia consente di ottenere un bianco puro oltre a tutte le gradazioni cromatiche, senza l'influenza dei colori RGB (vedi foto).

*This technology makes it possible to achieve pure white in addition to every shade of colour, without the influence of RGB colours.*



Cod. KE2  
Controller DMX Driver (Pag. 207)

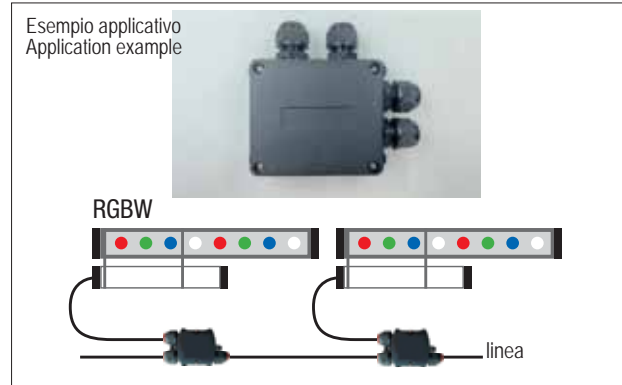

Cod. XPG9-P104  
Accessorio IP67 per linee di luce continua  
IP67 accessory for continuous light lines.



Completo di connettore IP68 per una rapida installazione  
*Complete with IP68 connector for quick installation*

## Schema di collegamento - Wiring diagram

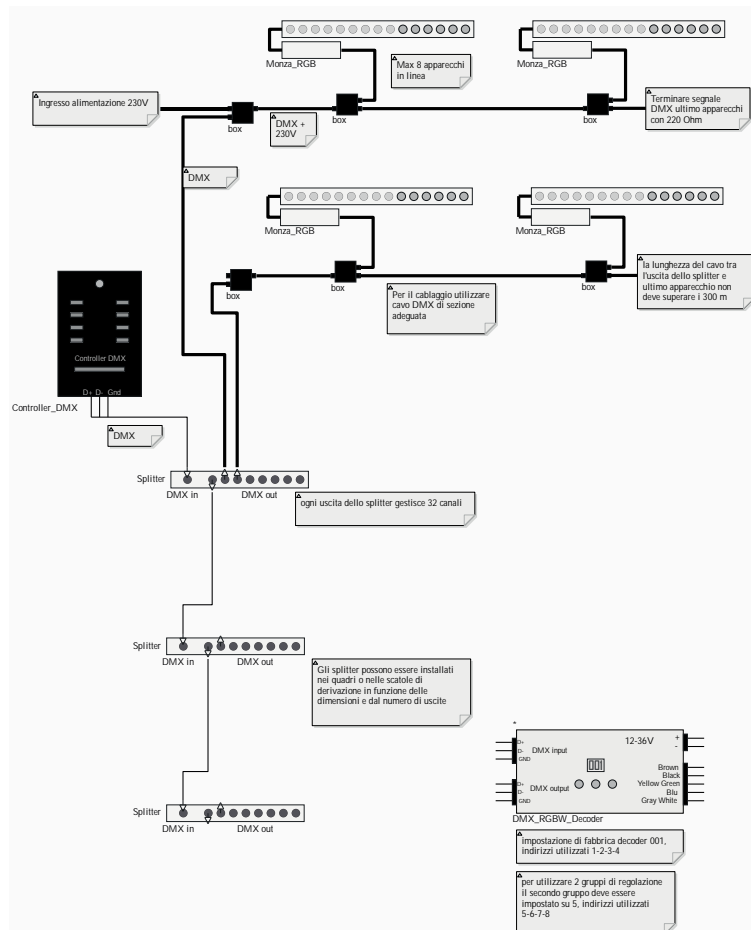

# LED Rondò RGB



Apparecchio da esterno, ad alto grado di protezione, utilizzabile ad incasso ideale per giardini, parchi, aiuole, terrazzi.

**Installazione:** incassi a pavimento adatti per illuminare percorsi pedonali, aree verdi, porticati, edifici sia residenziali che pubblici.

**Cassaforma:** inclusa.

**Corpo:** in alluminio pressofuso. Verniciatura di tipo poliestere eseguita a polvere resistente agli agenti atmosferici e alla nebbia salina. Ghiera e viterie in acciaio Inox AISI 316L.

**Schermo:** vetro temperato 4mm resistente agli shock termici e agli urti.

**Guarnizioni:** in gomma silconica.

**Norme di riferimento**

EN60598-1; EN60598-2-1; EN62471; EN62031; EN61547

**Sorgente:** LED COB 30W Full color

*Luminaire for outdoor use, with high protection degree, for recessed installation, for gardens, parks, flowerbeds*

*Installation: floor recessed luminaires suitable for illuminating pedestrian paths, green areas, porches, buildings either public or domestic.*

*Recessed housing: included.*

*Housing: die-cast aluminium body. Polyester powder coating. Resistance to atmospheric agents and corrosion guaranteed in saline mist. Closing ring and screws in stainless steel AISI 316L.*

*Shield: 4mm tempered glass resistant against thermal shocks and collisions.*

*Gaskets: made with silicone rubber.*

**Standard reference**

EN60598-1; EN60598-2-1; EN62471; EN62031; EN61547

**Source:** LED COB 30W Full color

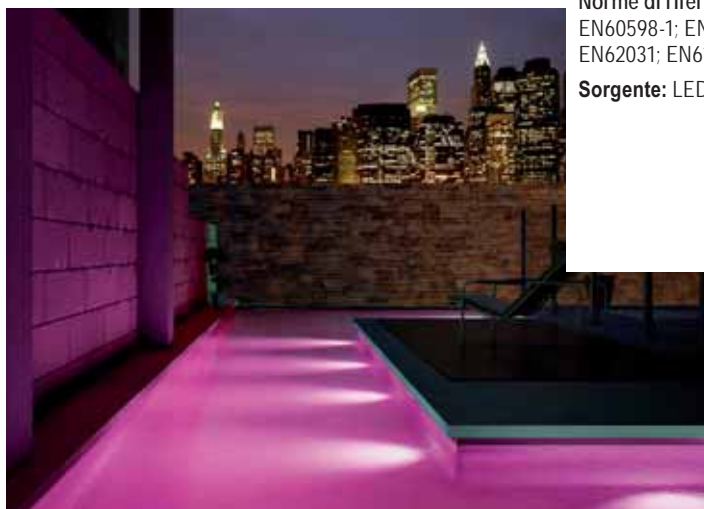

RGB

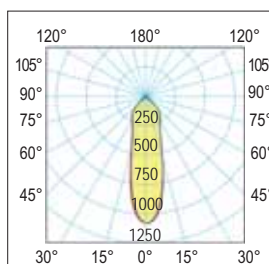
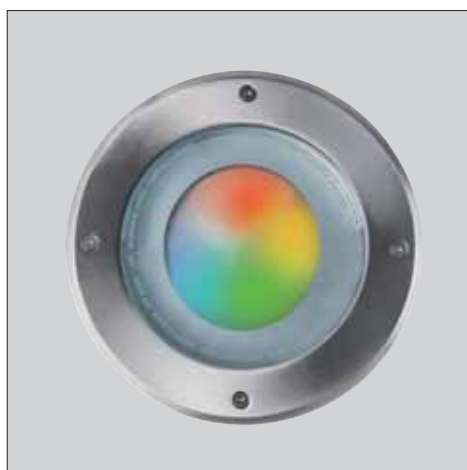

**25°**  
Semi concentrante - Spot

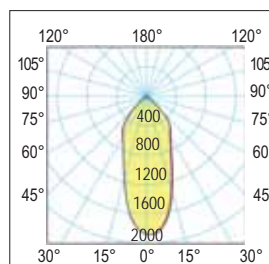

**A richiesta - On demand**  
**40°**  
Intermedio - Medium

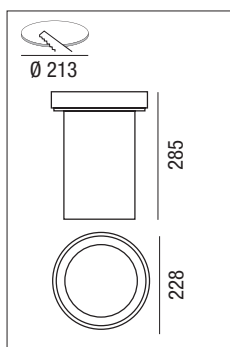
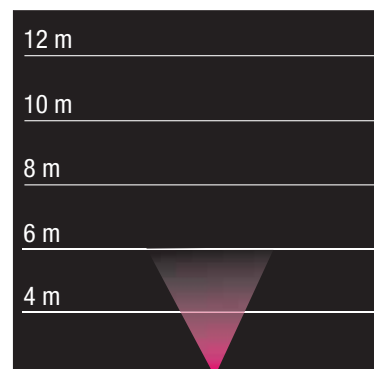

220-240 Vac	50/60 Hz	IP67	IK10	+40°C -20°C	850°		
		CE	Driver included				

colour	W	angle	K	nominal lm tc = 25°C	lm output	lm/W	pcs	Kg	CELL
C	30	25°	FULL COLOR		R = 145 - G = 320 B = 75	-	1	3,8	32567/RGB

# LED Rondò RGB

Schema di collegamento - *Wiring diagram*

KE2  
DMX controller

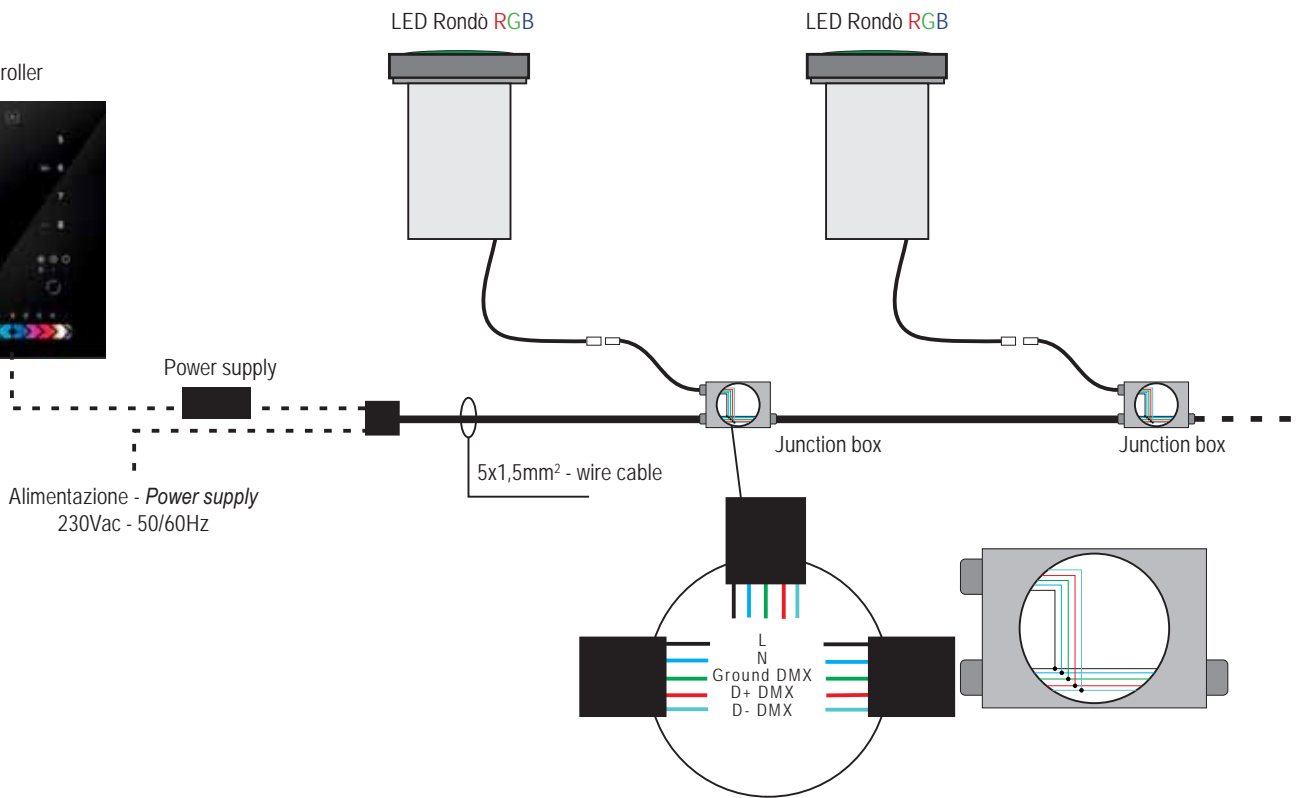

Cod. KE2 - DMX controller (Pag. 207)

La centralina di controllo DMX è la soluzione perfetta per qualunque esigenza di controllo dell'illuminazione interna.

*This complete stand alone wall-mounted DMX controller is the perfect answer to interior lighting control expectations.*



Calpestabile e carrabile, fino a 10Km/h - 1000 Kg con pneumatici gonfiati ad aria. Non sostare.

*Walkable and suitable for vehicles, up to 10Km/h - 1000Kg with tyres inflated with compressed air. Do not stand.*

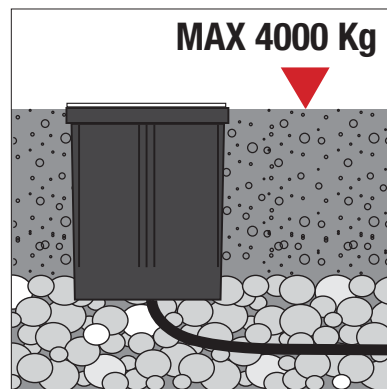

In caso di posa in muratura, la struttura muraria deve sostenere un carico di 4000 Kg. Il fondo della cassaforma è aperto, si rende necessario un fondo di ghiaia per il drenaggio.

*In the event of masonry laying, the wall structure must withstand a load of 4000 Kg. The bottom of the framework is open, it's necessary a gravel bottom for drainage.*



# LED Gargano RGB



Innovativi proiettori a LED per applicazioni professionali nell'illuminazione di facciate, portici, sottopassaggi e in generale per l'illuminazione di particolari elementi architettonici.

**Installazione:** su palo o parete/plafone (completo di staffa di fissaggio).

**Corpo e telaio:** in alluminio pressofuso UNI EN 1706 verniciato con polvere termoindurente poliestere.

**Staffa di fissaggio:** in acciaio, verniciata con polvere termoindurente poliestere, con goniometro graduato per un corretto puntamento del fascio luminoso.

**Verniciatura:** di tipo poliestere eseguita a polvere, resistente agli agenti atmosferici e alla corrosione. Colore Grigio RAL 9007.

**Norme di riferimento**

IEC 61000-4-5; EN60598-1; EN60598-2-1; EN62471; EN62031; EN60598-2-5; EN61547

*Innovative LED projectors for professional lighting applications on facades, arcades, tunnels and generally to light up particular architectural elements.*

*Installation: on vertical and horizontal surfaces (complete with fixing bracket)*

*Housing and frame: made by UNI EN 1706 die-cast aluminum, coated with polyester thermoset powder.*

*Fixing bracket: made by stainless steel, coated with polyester thermoset powder, with graduated goniometer to allow the correct orientation of light beam*

*Coating: coated with powdered polyester, resistant to atmospheric agents and corrosion.*

*Grey colour RAL 9007*

**Standard reference**

IEC 61000-4-5; EN60598-1; EN60598-2-1; EN62471; EN62031; EN60598-2-5; EN61547

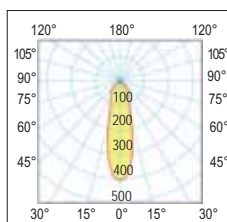

25°  
Semi-concentrante - Spot

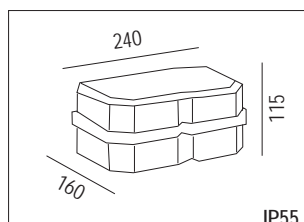

Cassetta stagna inclusa  
Watertight box included



Cod. KE2 - DMX controller (Pag. 207)

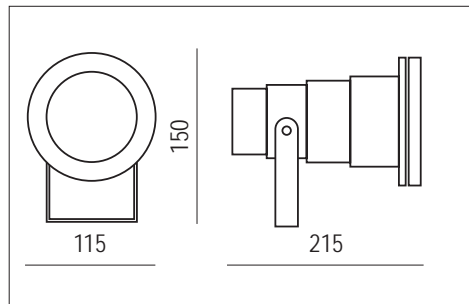

220-240 Vac	50/60 Hz	IP67	IK10	+40 C° -20	850°		
-------------	----------	------	------	---------------	------	--	--

		CE	Driver included			
--	--	----	-----------------	--	--	--

colour	W	angle	LED	lm Output	pcs	Kg	CELL
G	9	25°	FULL COLOR	R = 135 - G = 195 - B = 90	1	0,80	24292
N	9	25°	FULL COLOR	R = 135 - G = 195 - B = 90	1	0,80	24293

# LED Gargano RGB

## Accessori non inclusi - Not included accessories



Frangiluce - Louver				
colour	Ø (mm)	pcs	Kg	S
N	150	1	1,00	24136
G	150	1	1,00	24137



Frangiluce - Louver				
colour	Ø (mm)	pcs	Kg	S
N	150	1	1,00	24138
G	150	1	1,00	24139



Cassaforma per installazione a pavimento Framework for floor installation				
colour	H (mm)	pcs	Kg	S
N	240	1	1,00	24134
G	240	1	1,00	24135



Cod. 24165  
Picchetto in alluminio  
Aluminium spike

Schema di collegamento con controller DMX - DMX controller wiring diagram

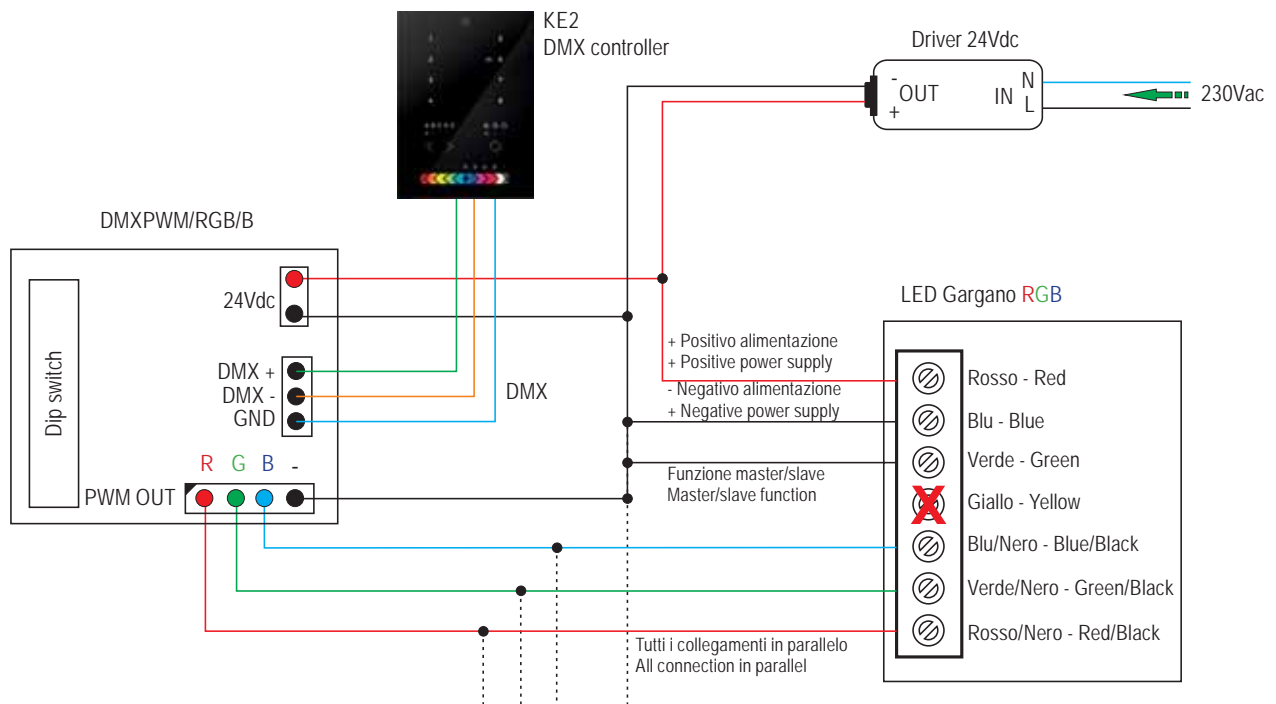

Schema di collegamento con comando a pulsante - Push button control wiring diagram

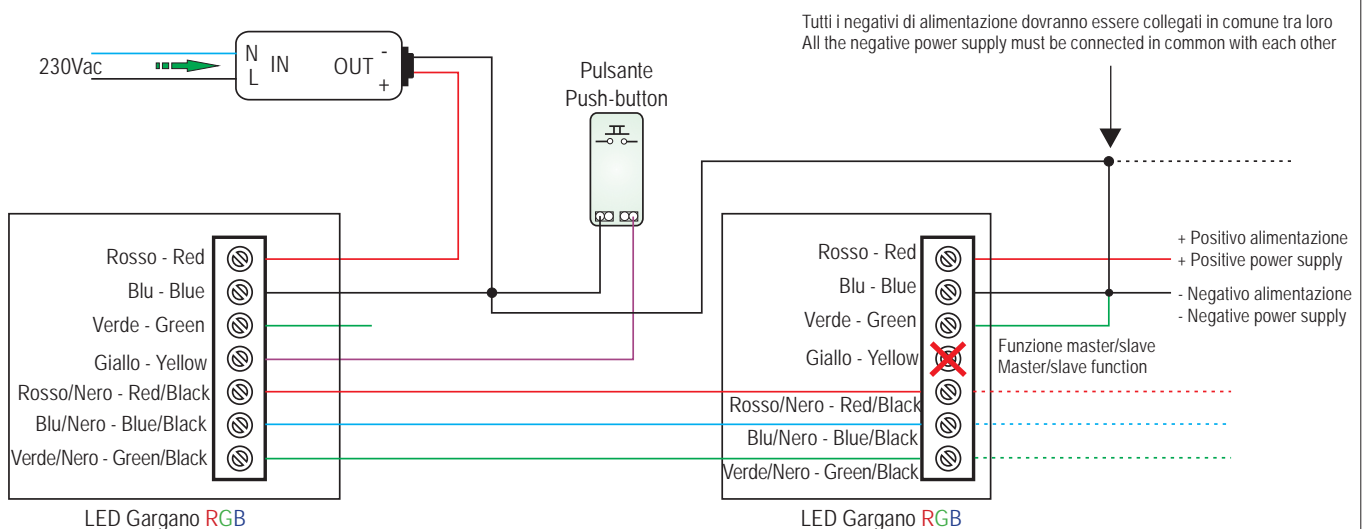

# LED FLEX RGB IP67



24Vdc

IP67

colour	W/m	Pitch	Led/mt*	Lm/m	Efficiency	pcs	Kg	S+L
T	14,4	60 LED RGB 5050	FULLCOLOR	600	42	1	0,38	90.001/RGB24V

Le misure di cui sopra possono avere una tolleranza del 10%.  
The above measurements can have a 10% tolerance

\*Quantità dei LED per metro lineare  
Quantity of LEDs per linear metre

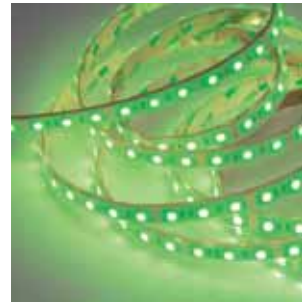

## Accessori inclusi - Included accessories

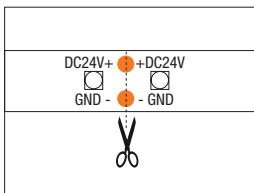

### Per codici IP67 - For IP67 code

La confezione contiene, clip di fissaggio, tappi di chiusura, cavi di collegamento IP ad alimentatore, tubo silicone per ripristino IP, connessioni iniziale e finale strip e per collegamento in serie. Le strip possono essere sezionate ad interassi prefissati; in caso di tagli intermedi utilizzare i tappi inclusi ed assicurarsi di sigillare accuratamente le estremità tagliate.

The package contains fixing clips, closure caps, IP connection cables to power supply, silicone hose for IP reset, initial and final strip connections and connection in series. The strips can be sectioned at preset intervals; in the case of intermediate cuts, use the included caps and make sure to carefully seal the cut ends.



Effettuare il taglio in corrispondenza del simbolo della forbice e la linea tratteggiata.

Make the cut in correspondence of the scissor symbol and dotted line.



# LED Flex COB - Digital RGB 24 Vdc IP20



24Vdc



CRI 90 IP20

colour	W/m	Pitch	K	Lm/m	Efficiency	pcs	Kg	Width mm.	S+L
T	6	100	Red	90	15	1	0,20	12	RCOB630212-D
	6		Green	240	40				
	6		Blue	48	8				
	14		Mixed white	350	25				

Strip LED, ideali per illuminazione lineare e indiretta.  
Ingresso a bassa tensione 24Vdc per la sicurezza umana.

Strip LED ideal for linear and indirect lighting.  
24Vdc low voltage input for human safety.



# LED Flex RGB

Comando sincronizzato con pulsante isolato - *Synchronizd control with isolated button*

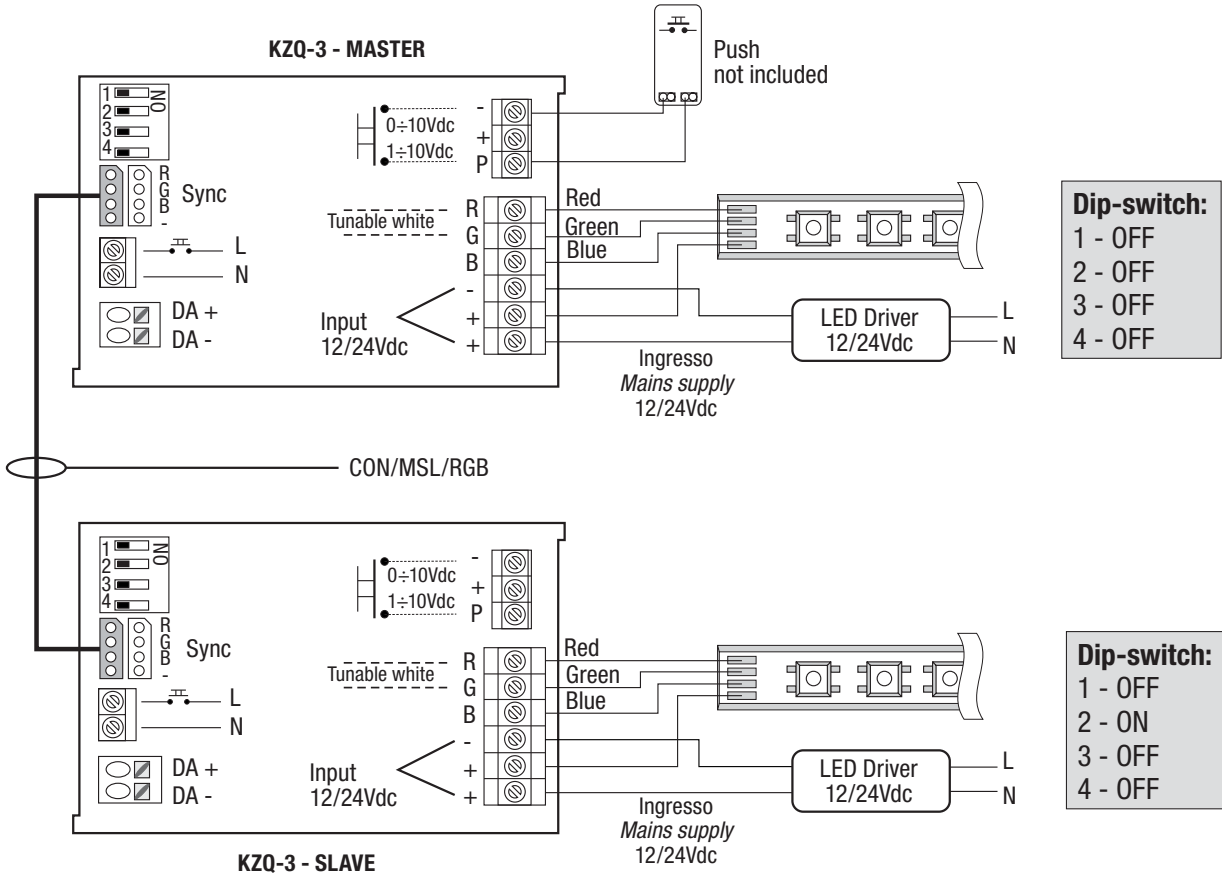

Esempio applicativo con centralina DMX - *Application example with DMX control uni*

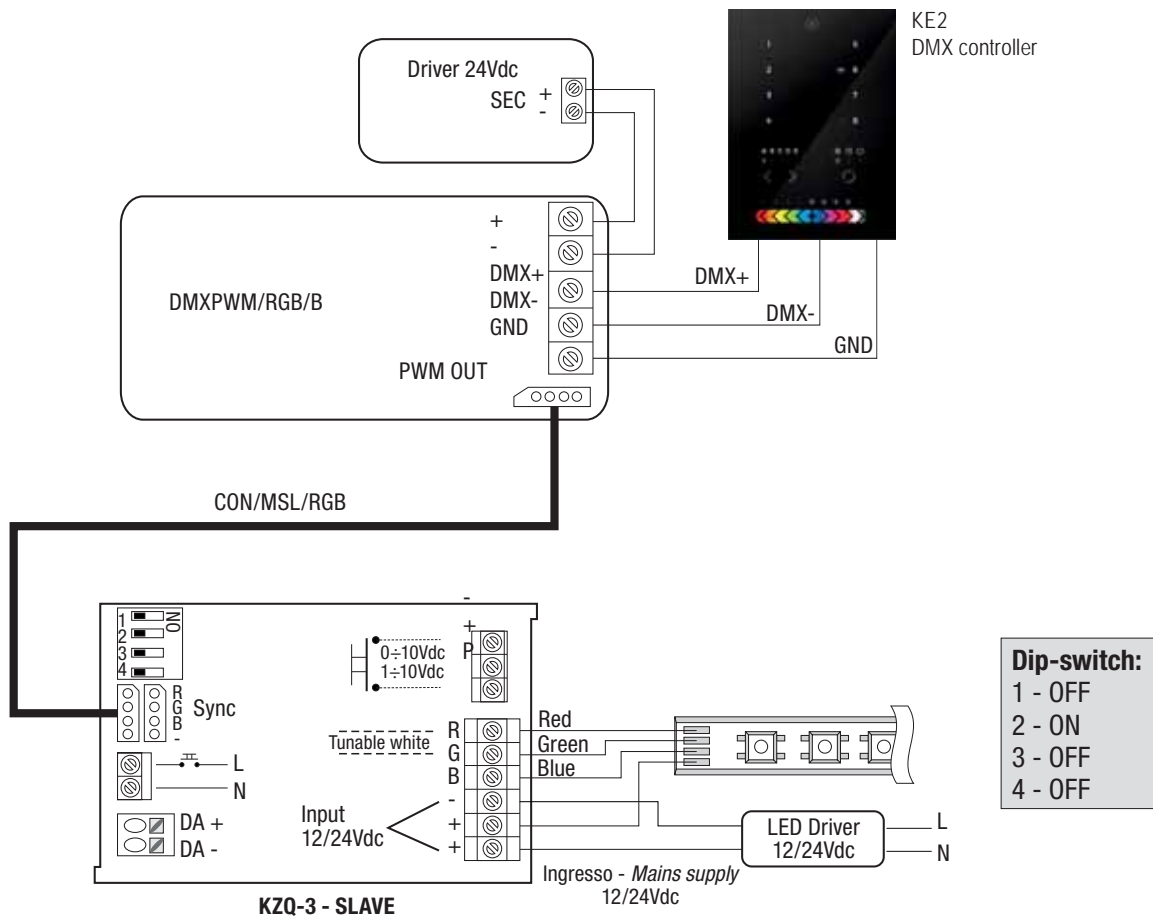

# LED Lampo RGBW



Innovativi proiettori a LED di semplice installazione. Per applicazioni professionali nell'illuminazione di facciate, portici, sottopassaggi e in generale per l'illuminazione di particolari elementi architettonici.

**Installazione:** sospensione, parete/plafone e testa palo (completo di staffa di fissaggio).

**Corpo:** in alluminio estruso anodizzato.

**Telaio:** in acciaio verniciato con polvere termoindurente poliester.

**Staffa di fissaggio:** in acciaio, verniciata con polvere termoindurente poliester

**Verniciatura:** di tipo poliester eseguita a polvere, resistente agli agenti atmosferici e alla corrosione. Colore Grigio RAL 9007.

**Optica:** diffondente

**Lenti:** PMMA autoestinguenti antiurto

**Protezione alle sovratensioni inclusa:**

Modo differenziale 6kV (L-N)

Modo comune 10kV (L-GND, N-GND, L&N-GND)

**LED Driver e Controller RGBW inclusi:**

Conforme alla Norma: IEC 61000-4-5.

Fattore di potenza:  $\geq 0,98$

**Norme di riferimento**

IEC 61000-4-5; EN 60598-1;

EN60598-2-1; EN62471; EN62031;

EN60598-2-5; EN61547

*Innovative LED projectors that are easy to install. For professional lighting applications on facades, arcades, tunnels and generally to light up particular architectural elements.*

*Installation: on vertical and horizontal surfaces (complete with fixing bracket)*

*Housing: n anodized extruded aluminium.*

*Frame: in steel painted with thermosetting polyester powder.*

*Fixing bracket: made by stainless steel, coated with polyester thermoset powder.*

*Coating: coated with powdered polyester, resistant to atmospheric agents and corrosion. Grey colour RAL 9007*

*Optic: diffused*

*Lenses: self-extinguishing shockproof PMMA*

*Protection against overvoltages included:*

*Differential mode 6kV (L-N)*

*Standard mode 10kV (L - GND, N-GND, L&N-GND).*

*LED Driver and RGB controller:*

*Conforming to IEC 61000-4-5.*

*Power factor:  $\geq 0,98$*

*Standard reference*

*IEC 61000-4-5; EN60598-1;*

*EN60598-2-1; EN62471; EN62031;*

*EN60598-2-5; EN61547*

RGB

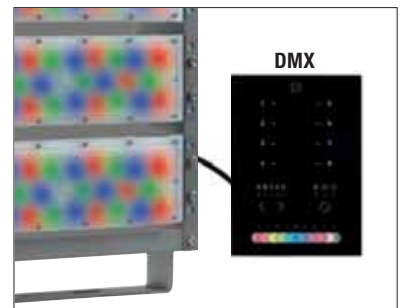
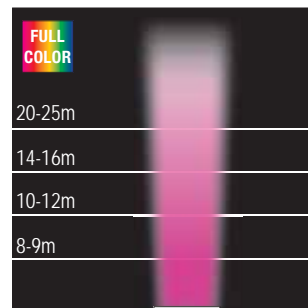
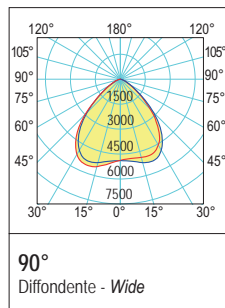
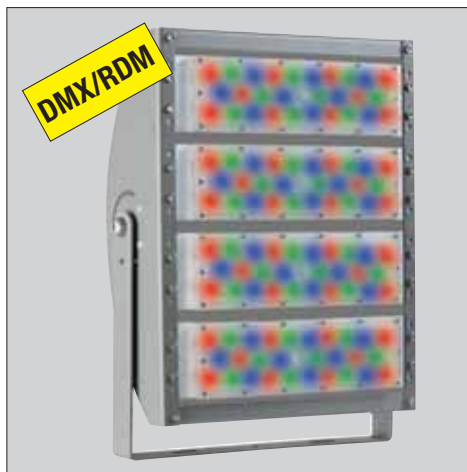

Lampo RGB 240W

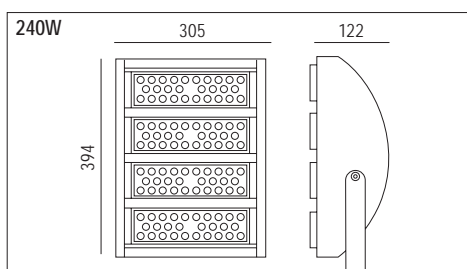
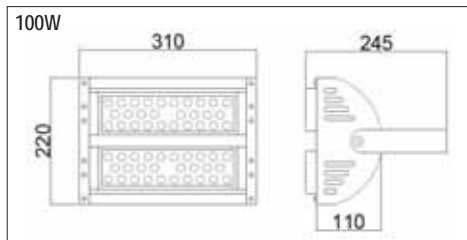

100-240 Vac	50/60 Hz	IP66	IK10	+40 C -40	850°		
		CE	Driver included				

colour	W	LED	angle	lm output	pcs	Kg	CELL
G	100	FULL COLOR	90°	R = 480 - G = 1000 - B = 400 W = 1800	1	2,90	RFL90-RGB
G	240	FULL COLOR	90°	R = 960 - G = 2000 - B = 800 W = 3600	1	5,40	RFL180-RGB

# LED Lampo RGBW

Schema di collegamento - *Wiring diagram*

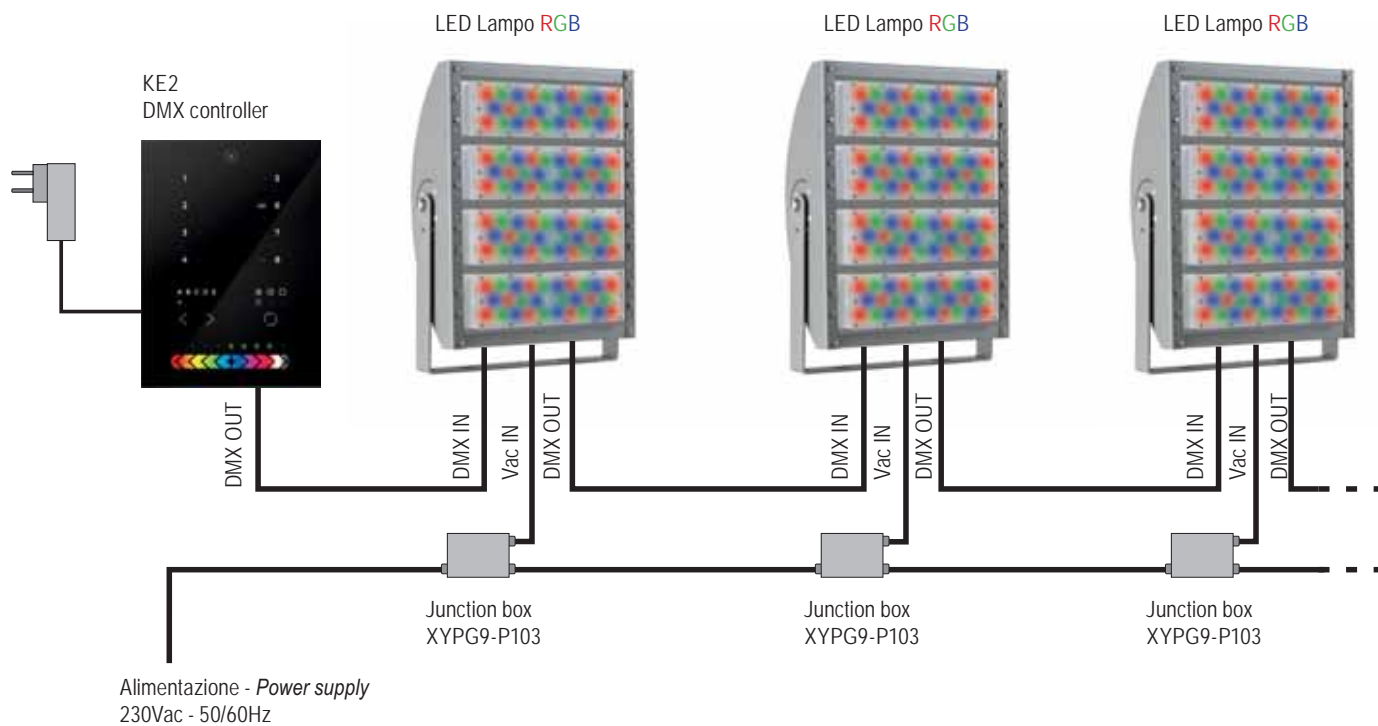

Cod. KE2 - DMX controller (Pag. 207)

La centralina di controllo DMX è la soluzione perfetta per qualunque esigenza di controllo dell'illuminazione interna.

*This complete stand alone wall-mounted DMX controller is the perfect answer to interior lighting control expectations.*

## Ottiche a richiesta - *Optics on demand*

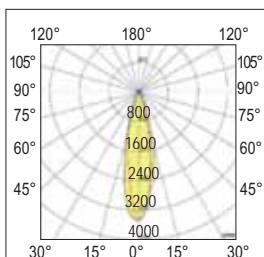

25°  
Concentrante - *Spot*

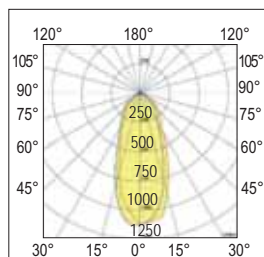

40°  
Semi-diffondente - *Wide*

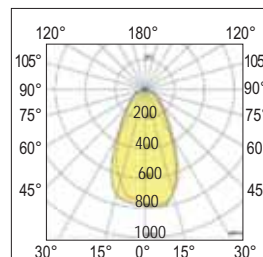

60°  
Diffondente - *Flood*



Questa tecnologia consente di ottenere un bianco puro oltre a tutte le gradazioni cromatiche, senza l'influenza dei colori RGB (vedi foto).

*This technology makes it possible to achieve pure white in addition to every shade of colour, without the influence of RGB colours.*



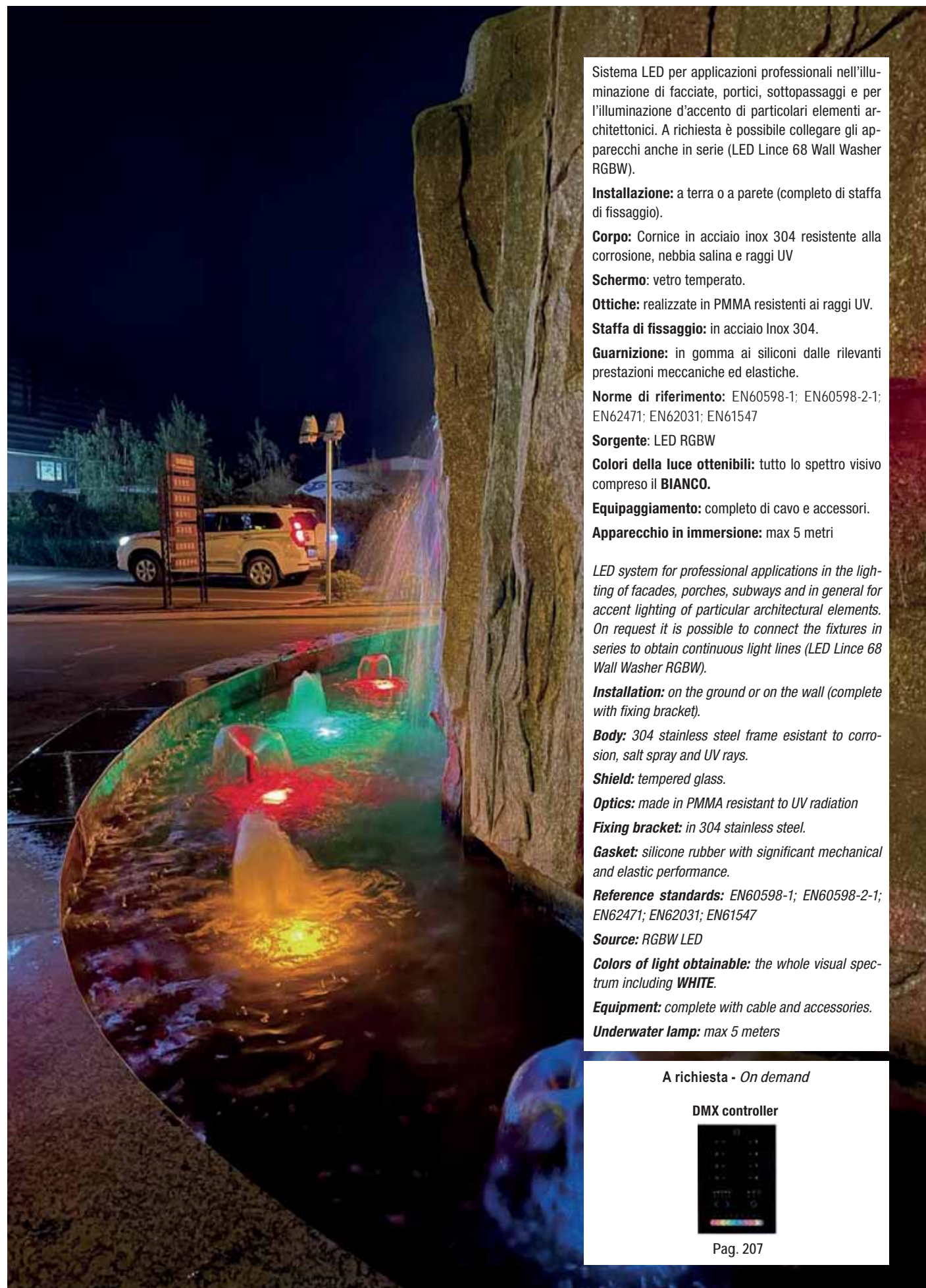

Sistema LED per applicazioni professionali nell'illuminazione di facciate, portici, sottopassaggi e per l'illuminazione d'accento di particolari elementi architettonici. A richiesta è possibile collegare gli apparecchi anche in serie (LED Lince 68 Wall Washer RGBW).

**Installazione:** a terra o a parete (completo di staffa di fissaggio).

**Corpo:** Cornice in acciaio inox 304 resistente alla corrosione, nebbia salina e raggi UV

**Schermo:** vetro temperato.

**Ottiche:** realizzate in PMMA resistenti ai raggi UV.

**Staffa di fissaggio:** in acciaio Inox 304.

**Guarnizione:** in gomma ai siliconi dalle rilevanti prestazioni meccaniche ed elastiche.

**Norme di riferimento:** EN60598-1; EN60598-2-1; EN62471; EN62031; EN61547

**Sorgente:** LED RGBW

**Colori della luce ottenibili:** tutto lo spettro visivo compreso il **BIANCO**.

**Equipaggiamento:** completo di cavo e accessori.

**Apparecchio in immersione:** max 5 metri

*LED system for professional applications in the lighting of facades, porches, subways and in general for accent lighting of particular architectural elements. On request it is possible to connect the fixtures in series to obtain continuous light lines (LED Lince 68 Wall Washer RGBW).*

**Installation:** on the ground or on the wall (complete with fixing bracket).

**Body:** 304 stainless steel frame resistant to corrosion, salt spray and UV rays.

**Shield:** tempered glass.

**Optics:** made in PMMA resistant to UV radiation

**Fixing bracket:** in 304 stainless steel.

**Gasket:** silicone rubber with significant mechanical and elastic performance.

**Reference standards:** EN60598-1; EN60598-2-1; EN62471; EN62031; EN61547

**Source:** RGBW LED

**Colors of light obtainable:** the whole visual spectrum including **WHITE**.

**Equipment:** complete with cable and accessories.

**Underwater lamp:** max 5 meters

A richiesta - On demand

DMX controller



Pag. 207

# LED Lince 68 RGBW

**NEW**

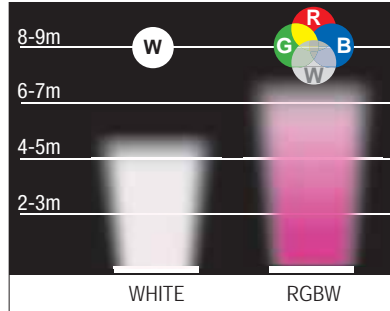
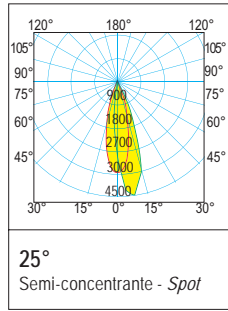

Questa tecnologia consente di ottenere un bianco puro oltre a tutte le gradazioni cromatiche, senza l'influenza dei colori RGB (vedi foto).  
*This technology makes it possible to achieve pure white in addition to every shade of colour, without the influence of RGB colours.*

24Vdc IP68 IK08 +60°C/-25°C 850° Driver NOT included CE FULL COLOR

colour	W	angle	LED	lm -output	pcs	Kg	S+L
S	36	25°	FULL COLOR	R = 235 - G = 351 - B = 85 W = 380 (6500K)	001	1,440	RGBW16DMX

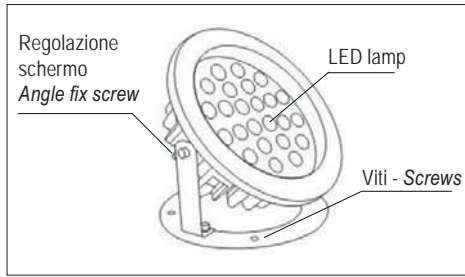
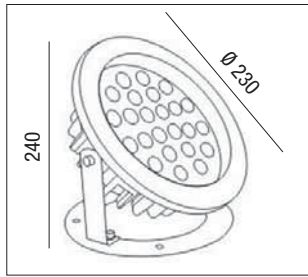

# LED Lince 68 Wall Washer RGBW

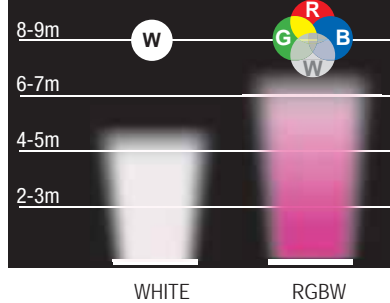
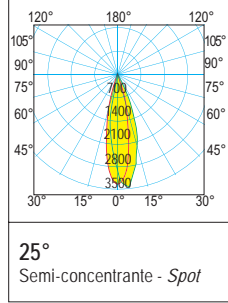

Questa tecnologia consente di ottenere un bianco puro oltre a tutte le gradazioni cromatiche, senza l'influenza dei colori RGB (vedi foto).  
*This technology makes it possible to achieve pure white in addition to every shade of colour, without the influence of RGB colours.*

24Vdc IP68 IK08 +60°C/-25°C 850° Driver NOT included CE FULL COLOR

colour	W	angle	LED	lm -output	pcs	Kg	S+L
S	36	25°	FULL COLOR	R = 198 - G = 304 - B = 75 W = 335 (6500K)	001	1,440	RGBW18DMX

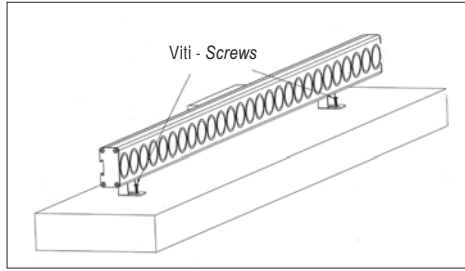
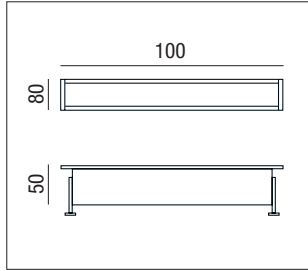

RGB

LED Lince 68 RGBW - Schema di collegamento - *Wiring diagram*

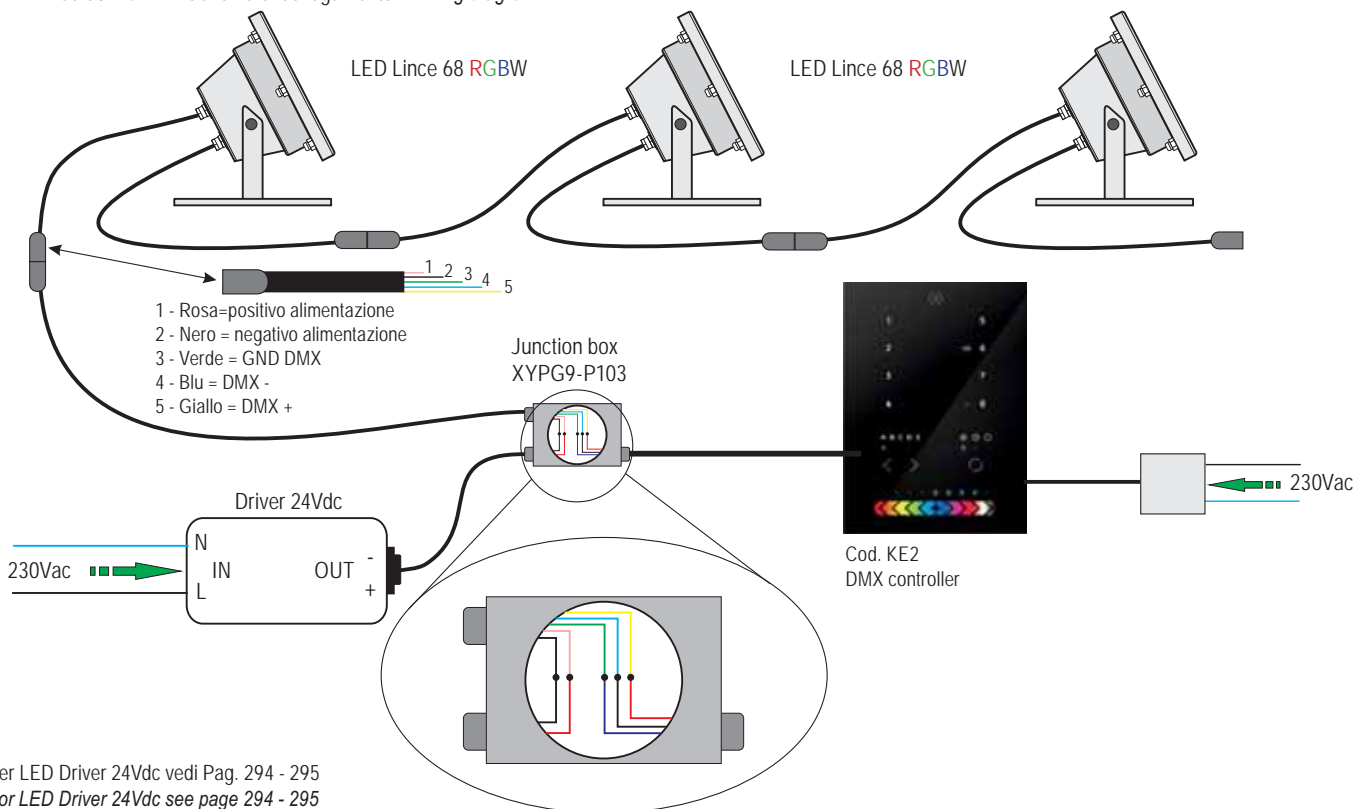

LED Lince 68 Wall Washer RGBW - Schema di collegamento - *Wiring diagram*

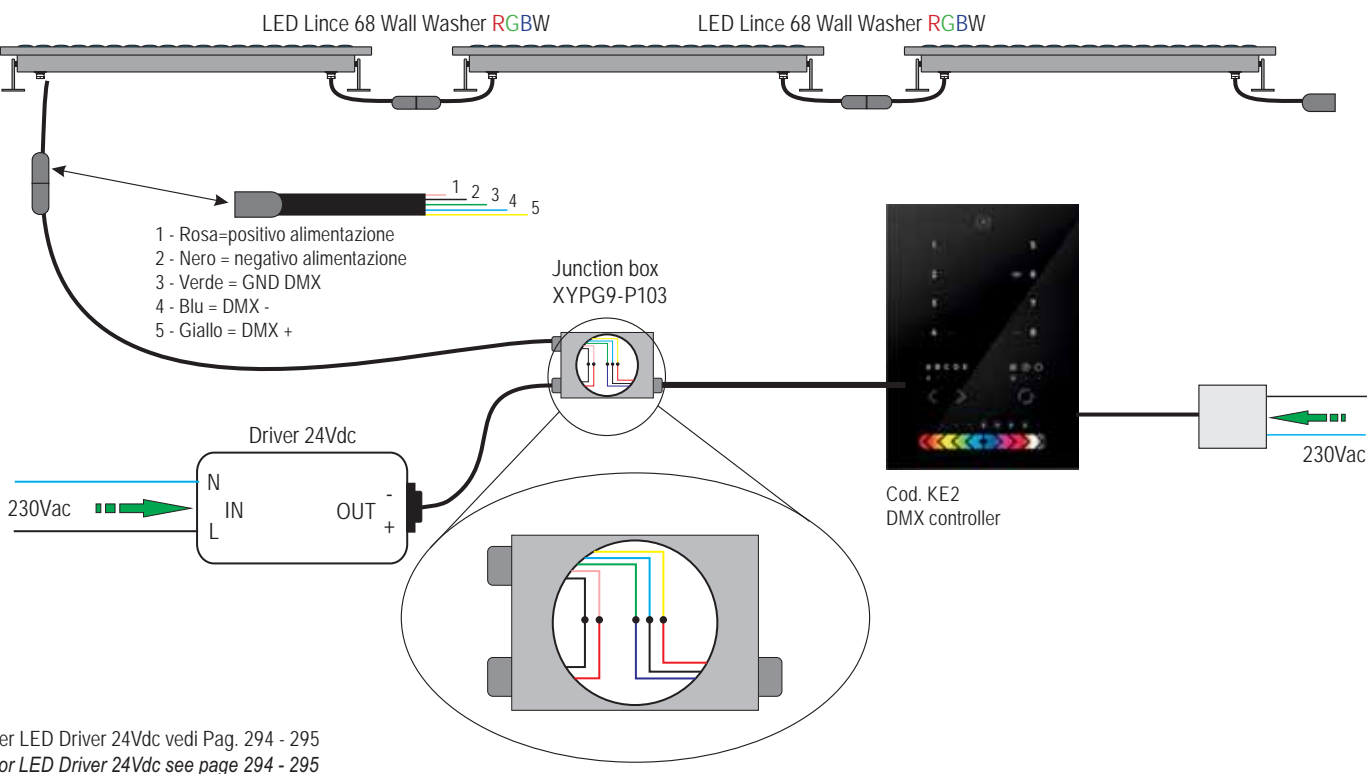



# Accessori - Accessories



**Cod. KE2**  
Centralina di controllo DMX utilizzabile in modalità stand alone.  
**Nel prezzo di questo codice non è inclusa la programmazione**  
*DMX control unit for use in stand alone mode.*  
*Programming is not included in the price of this code*  
**ALTRI MODELLI PIÙ ECONOMICI SONO ACQUISTABILI ON-LINE**  
**CHEAPER MODELS CAN BE PURCHASED ONLINE**

**Controller DMX programmabile in grado di funzionare in modalità stand alone. Selezione delle scene programmate tramite tastiera touch: pulsanti per la selezione dello scenario, regolazione luminosità, selezione colore, velocità scenografia, accensione/spegnimento.**

- Compatibile con USITT DMX512A
- Connessione USB per programmazione
- Canali DMX 2x512
- Controllo touch panel
- Programmazione tramite pc
- Memoria esterna micro SD 512 Mb (fornita)
- Alimentatore per il funzionamento in modalità stand alone (fornito)

*Programmable DMX controller capable of operating in stand alone mode. Selection of the programmed scenes via the touch keyboard: buttons for selecting the scenario, adjusting the brightness, selecting the color, setting speed, on / off.*

- Compatible with USITT DMX512A
- USB connection for programming
- 2x512 DMX channels
- Touch panel control
- Programming via PC
- 512 Mb micro SD external memory (supplied)
- Power supply for stand alone operation (supplied)



**Cod. DMXPWM/RGB/B**  
Interfaccia di connessione per FLEX LED RGB e LED GARGANO RGB  
*Interface for connection for FLEX LED RGB and LED GARGANO RGB*

Il prodotto DMXPWM/RGB è un'interfaccia di connessione fra sistemi DMX e moduli slave per il controllo colore.

Ogni interfaccia DMXPWM/RGB usa 3 canali DMX per generare 3 segnali di controllo colore (Rosso - Verde - Blu), che vengono inviati al modulo Slave per il controllo colore.

L'interfaccia DMXPWM/RGB dispone di 10 Dip-Switches per impostare (in codice binario) l'indirizzo "X" del primo canale DMX usato dall'interfaccia

*The DMXPWM/RGB product is an interface for connection between DMX systems and RGB slave dimmers.*

*Each DMXPWM/RGB interface uses 3 DMX channels to generate 3 colour (Red, Green and Blue) control signals, which are sent to RGB slave dimmer.*

*The DMXPWM/RGB interface has got 10 Dip-Switches to set the "X" adress of the first DMX channel used by interface.*



**KZQ-1 - Cod. 30928**  
Controller per FLEX LED RGB  
*FLEX LED RGB controller*

Controller RGB per uso indipendente con comando a pulsante incorporato da abbinare agli alimentatori Miniled.

**Potenza: 30W - V out: 12Vdc - V in: 12Vdc**

Il passaggio da un programma all'altro avviene premendo il pulsante ed è evidenziato da un diverso segnale acustico tipo beep. Il pulsante di comando è integrato nel regolatore ed è in grado di gestire tre differenti programmi luminosi

- 1) Un colore monocromatico a luce fissa (1 Beep)
- 2) Cambio dei colori di tipo passo-passo (2 Beeps)
- 3) Cambio dei colori di tipo ciclico FULL COLOR (3 Beeps)
- 4) Spegnimento (4 Beeps).

*RGB controller for independent use with incorporated push-button control to be continued with Mini-led feeders.*

**Potenza: 30W - V out: 12Vdc - V in: 12Vdc**

*The passage from one program to another occurs by different beep-type acoustic signal.*

*The control button is integrated in the regulator, and is able to manage three different lighting programs.*

- 1) A monochromatic colour with steady light (1 Beep)
- 2) Step-by-step colour change (2 Beeps)
- 3) Cyclical FULL COLOR change (3 Beeps)
- 4) Turn off (4 Beeps).

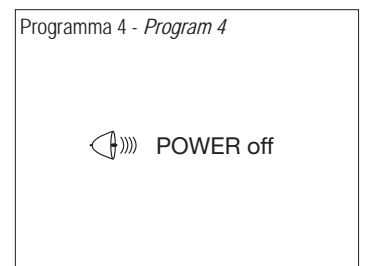
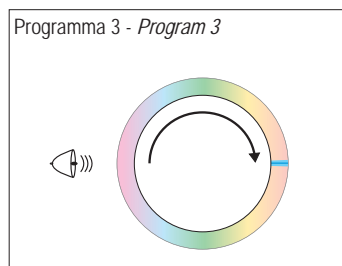
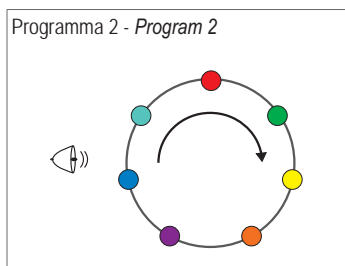
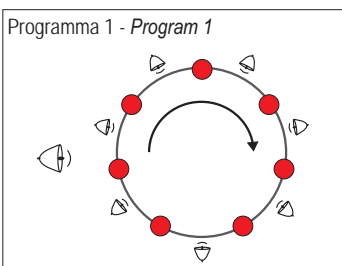

## Accessori - Accessories



### KZQ-3 - Cod. 30948

Controller per FLEX LED RGB - *FLEX LED RGB controller*

La regolazione può avvenire nei seguenti modi:	Adjustment can be made as follows:
Pulsante NA selv (isolato da rete)	Selv NO push-button (mains insulated)
Pulsante NA non selv (riferito sulla rete)	Non Selv NO push-button (referred to on mains)
Ciclo continuo all'accensione con atmosfere preimpostate	Continuous cycle at start-up with preset atmospheres
Regolazione singoli colori	Adjusting individual colors
Selezione sequenza singoli colori	Individual color sequence selection
Regolazione DMX tramite convertitori DMX/PWM	DMX adjustment via DMX/PWM converters

**Regolazione a pulsante:** la regolazione RGB avviene agendo direttamente sul pulsante. L'accensione e lo spegnimento avvengono tramite un breve tocco sul pulsante. Per ottenere la regolazione RGB, premere il pulsante sino a raggiungere il colore desiderato, una volta raggiunto interrompere il contatto. Sarà inoltre possibile, previa impostazione dei dip-switch, dimmerare i singoli colori, oppure ottenere l'accensione, ad ogni pressione del pulsante la sequenza dei colori fissi RGB. Memoria del livello, salvo interruzioni di rete.

**Atmosfere preimpostate:** all'accensione dell'impianto, tramite interruttore di rete, il ciclo RGB inizierà a ciclare in automatico

**Regolazione dei singoli colori:** selezionare tramite dip-switch il colore da regolare, sarà quindi possibile effettuare la regolazione a pulsante.

**Accensione sequenziale dei singoli colori:** selezionare la funzione tramite dip-switch. Ad ogni pressione del pulsante si avrà l'accensione dei singoli colori alla massima intensità.

**Regolazione DMX:** la regolazione tramite centraline DMX è possibile abbinando anche la nostra interfaccia cod. DMX/PWM/RGB/B e cavo di sincronismo CON/MSL/RGB.

*Push-button adjustment: act on the push button to adjust the RGB. Briefly touch the push-button to switch on and off. To adjust the RGB, press the push-button until the desired colour is obtained and then interrupt contact. After setting the dip-switches, single colours may be dimmed or the sequence of RGB steady colours lighted up by pressing the push-button. Level memory, except in case of black outs.*

*Preset atmospheres: when the system is switched on, the RGB cycle will start to automatically run by pressing a mains switch*

*Adjustment of individual colors: select by dip-switch the color to be adjusted, it will then be possible to adjust by button.*

*Sequential switching on of the single colors: select the function via dip-switch. Each time the button is pressed, the individual colors will be turned on at maximum intensity.*

*DMX adjustment: adjustment via DMX control units is also possible by connecting our interface cod. DMX/PWM/RGB/B*



### Cod. CON/MSL/RGB

Cavo di sincronismo - *Sync cable*

Nel caso in cui sia necessaria gestire una potenza maggiore sarà possibile collegare in modo sincronizzato, tramite cavo di sincronismo, fino ad un massimo di 10 apparecchiature selezionando, con i dip-switch, il funzionamento MASTER-SLAVE.

*Should greater power be needed, up to a maximum of 10 devices can be connected in a synchronized way, using a sync cable, by selecting MASTER-SLAVE operation via dip-switches.*



### Cod. XPG9-P104

Accessorio IP67 per linee di luce continua  
IP67 accessory for continuous light lines.



### Cod. XYPG9-IP67

Accessorio IP68 per linee di luce continua  
IP68 accessory for continuous light lines.

**NEW**

**VS LIGHTING SOLUTIONS**



## Collegiamo la luce per te - We connect light for you

Blu2Light è da anni un sistema di controllo wireless ben collaudato per qualsiasi tipo di applicazione di illuminazione interna. Ora è possibile utilizzare la stessa tecnologia per le applicazioni di illuminazione stradale e anche l'illuminazione architettonica : Gestione della luce - scenari - presenza - dimmerazione - Astro Time Switching - Integrazione di planimetrie e mappe stradali - Integrazione della comunicazione

### **SICUREZZA prima di tutto!**

CODICE QR UNIVOCO Crittografia grazie alla scansione del codice QR

Le connessioni MESH sono crittografate

La comunicazione Bluetooth® è crittografata

**New - Controller Bluetooth® (versione NEMA e ZHAGA socket) per la gestione di apparecchi di illuminazione stradale**

**New - Controller Bluetooth® con GPS integrato (versione NEMA e ZHAGA socket) per la gestione di apparecchi di illuminazione stradale**

**New Controller IP67 Bluetooth® per applicazioni da esterno**

Blu2Light has been a well-proven wireless control system for any type of indoor lighting application for years.

Now you can use the same technology for street lighting applications and also architectural lighting:

Light management - scenarios - presence - dimming - Astro Time Switching - Integration of floor plans and road maps - Communication integration

### **SAFETY first!**

UNIQUE QR CODE Encryption thanks to QR code scanning

MESH connections are encrypted

Bluetooth® communication is encrypted

**New - Bluetooth® Controller (NEMA and ZHAGA socket versions) for the management of street lighting fixtures**

**New - Bluetooth® Controller with integrated GPS (NEMA and ZHAGA socket versions) for the management of street lighting fixtures**

**New IP67 Bluetooth® Controller for outdoor applications**